

RECORD RANGE

SEDIS EXPERTISE *for your*
STANDARD APPLICATIONS



RECORD® RANGE

-  The **BEST VALUE** on the market
-  **AVAILABILITY:** many references available ex stock
-  **SALES CONTACTS** & Distributors in Europe and worldwide
-  Adaptation to **ALL TYPES** of light industrial **APPLICATIONS**
-  **CONSTANT** quality of material and tolerances
-  **PRECISION** assembly & **PRE-LUBRICATION**
-  Breaking loads conforming to and **EXCEEDING ISO STANDARDS** validated with UTS tests performed in certified laboratories

 **DID YOU KNOW?**

ALL OUR RECORD® CHAINS ARE
DESIGNED AND CONTROLLED BY
SEDIS

THE TECHNICAL STRENGTH OF A MAJOR MANUFACTURER

CHAINS PRE-TENSIONED AT 30% OF THE UTS AT THE FACTORY
REDUCTION OF THE INITIAL STRETCH



SOLID COLD EXTRUDED ROLLERS
BETTER IMPACT RESISTANCE

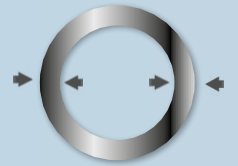

HIGH WEAR RESISTANCE
EXTENDED LIFE-TIME

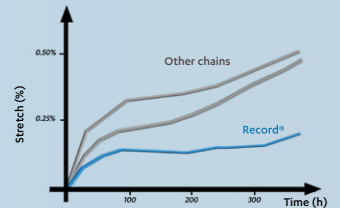

SHOT PEENING
INCREASED FATIGUE RESISTANCE

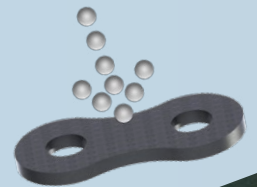

98%
OF CLIENTS ARE SATISFIED

**MORE THAN
20 000
USERS & OEMS**
SUPPORT RECORD® ALL AROUND THE WORLD



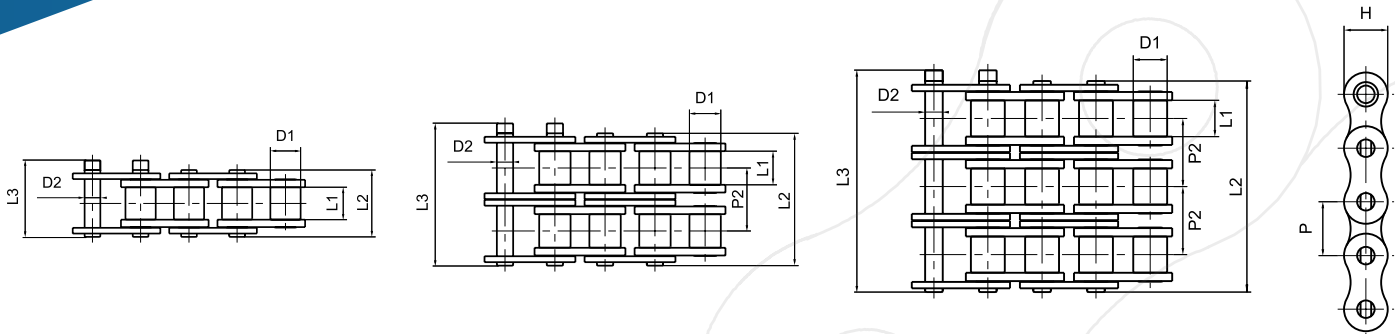

Dimensions in mm

SIMPLEX												
Ref	SEDIS reference	P mm	P inch	D1	H max	L1 min	D2	P2	L2	L3	Kg/m	UTS min (kN)
25-1	CA1N025000	6.35	1/4"	3.30	5.80	3.18	2.31	-	7.90	10.40	0.15	3.50
35-1	CA1N035000	9.525	3/8"	5.08	8.65	4.77	3.58	-	12.40	15.70	0.33	7.90
40-1	CA1N040000	12.70	1/2"	7.92	12.00	7.85	3.97	-	17.40	21.30	0.63	14.10
50-1	CA1N050000	15.875	5/8"	10.16	15.00	9.40	5.08	-	20.20	24.30	1.04	22.20
60-1	CA1N060000	19.05	3/4"	11.91	18.00	12.58	5.96	-	26.90	31.50	1.52	31.80
80-1	CA1N080000	25.40	1"	15.87	24.10	15.75	7.94	-	33.50	38.90	2.60	56.60
100-1	CA1N100000	31.75	1" 1/4	19.05	30.10	18.90	9.54	-	41.10	47.20	4.01	88.50
120-1	CA1N120000	38.10	1" 1/2	22.22	36.20	25.40	11.10	-	49.90	56.50	5.56	125.00
140-1	CA1N140000	44.45	1" 3/4	25.40	42.20	25.40	12.70	-	53.90	60.90	7.44	170.00
150-1	CA1N160000	50.80	2"	28.58	48.20	31.75	14.27	-	63.90	70.90	10.04	225.00
200-1	CA1N200000	63.50	2" 1/2	39.67	60.30	38.10	19.84	-	78.10	87.10	16.70	348.00

DUPLEX												
Ref	SEDIS reference	P mm	P inch	D1	H max	L1 min	D2	P2	L2	L3	Kg/m	UTS min (kN)
40-2	CA2N040000	12.70	1/2"	7.92	12.00	7.85	3.97	14.38	30.60	34.50	1.25	28.20
50-2	CA2N050000	15.875	5/8"	10.16	15.00	9.40	5.08	18.11	38.50	42.60	2.06	44.50
60-2	CA2N060000	19.05	3/4"	11.91	18.00	12.58	5.96	22.78	49.70	54.30	3.01	63.60
80-2	CA2N080000	25.40	1"	15.87	24.10	15.75	7.94	29.78	62.70	68.10	5.15	113.30
100-2	CA2N100000	31.75	1" 1/4	19.05	30.10	18.90	9.54	35.76	75.70	81.80	7.70	174.00
120-2	CA2N120000	38.10	1" 1/2	22.22	36.20	25.40	11.11	45.44	95.30	101.90	10.96	250.00
140-2	CA2N140000	44.45	1" 3/4	25.40	42.20	25.40	12.70	48.87	102.80	109.80	14.76	350.00
160-2	CA2N160000	50.80	2"	28.58	48.20	31.45	14.27	58.55	122.30	129.30	19.90	460.00
200-2	CA2N200000	63.50	2" 1/2	39.67	60.30	38.10	19.84	71.55	149.50	158.50	33.20	700.00

TRIPLEX												
Ref	SEDIS reference	P mm	P inch	D1	H max	L1 min	D2	P2	L2	L3	Kg/m	UTS min (kN)
40-3	CA3N040000	12.70	1/2"	7.92	12.00	7.85	3.97	14.38	45.30	49.20	1.98	42.30
50-3	CA3N050000	15.875	5/8"	10.16	15.00	9.40	5.08	18.11	56.80	60.90	3.07	66.70
60-3	CA3N060000	19.05	3/4"	11.91	18.00	12.58	5.96	22.78	72.60	77.20	4.51	95.40
80-3	CA3N080000	25.40	1"	15.87	24.10	15.75	7.94	29.78	91.90	97.10	7.71	170.00
100-3	CA3N100000	31.75	1" 1/4	19.05	30.10	18.90	9.54	35.76	113.00	119.10	11.86	265.50
120-3	CA3N120000	38.10	1" 1/2	22.22	36.20	25.40	11.11	45.44	141.70	147.60	17.01	380.70
140-3	CA3N140000	44.45	1" 3/4	25.40	42.20	25.40	12.70	48.87	152.40	159.40	22.64	517.00
160-3	CA3N160000	50.80	2"	28.58	48.20	31.75	14.27	58.55	182.90	189.90	29.22	680.00
200-3	CA3N200000	63.50	2" 1/2	39.67	60.30	38.10	19.84	71.55	223.50	233.00	49.21	1060.00

HEAVY DUTY AMERICAN SERIES CHAINS

H series (reinforced)												
Ref	SEDIS reference	P mm	P inch	D1	H max	L1 min	D2	P2	L2	L3	Kg/m	UTS min (kN)
50H	CA1N050H000	15.875	5/8"	10.16	14.48	9.40	5.07	-	22.10	24.50	1.20	21.77
60H	CA1N060H000	19.05	3/4"	11.91	18.00	12.58	5.96	-	31.20	35.80	1.81	31.80
80H	CA1N080H000	25.40	1"	15.87	24.10	15.75	7.94	-	38.00	43.40	3.00	56.50
100H	CA1N100H000	31.75	1" 1/4	19.05	30.10	18.90	9.54	-	45.40	51.50	4.38	88.50
120H	CA1N120H000	38.10	1" 1/2	22.22	36.20	25.23	11.11	-	55.10	61.70	6.61	126.90
140H	CA1N140H000	44.45	1" 3/4	25.40	42.20	25.22	12.71	-	60.40	67.80	8.33	172.40

STRAIGHT SIDED DOUBLE PITCH AMERICAN SERIES CHAINS – complying with ISO 1275

Straight sided double pitch												
Ref	SEDIS reference	P mm	P inch	D1	H max	L1 min	D2	P2	L2	L3	Kg/m	UTS min (kN)
C2040	CC1N2040000	25.40	1"	7.92	11.66	7.85	3.96	-	17.80	21.70	0.49	14.12
C2050	CC1N2050000	31.75	1" 1/4	10.16	14.58	9.40	5.08	-	21.80	25.90	0.81	22.26
C2060	CC1N2060000	38.10	1" 1/2	11.91	18.06	12.58	5.94	-	26.90	31.50	1.20	31.77
C2080	CC1N2080000	50.80	2"	15.88	24.05	15.75	7.92	-	33.50	38.90	2.10	56.68

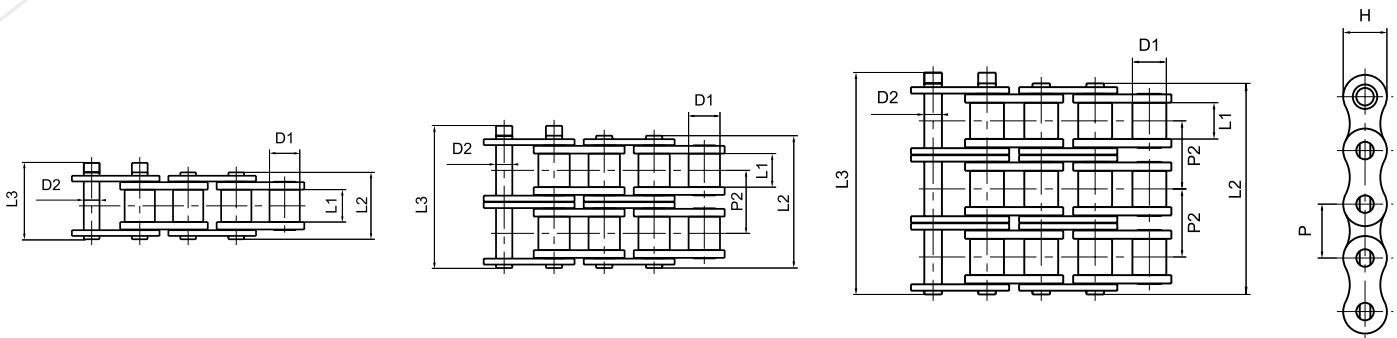

Dimensions in mm

SIMPLEX													
ISO	SEDIS reference	P mm	P inch	D1	H max	L1 min	D2	P2	L2	L3	Kg/m	UTS min (kN)	
-	CA1N04B000	6	-	4.00	5.00	2.80	1.85	-	6.80	7.90	0.11	3.20	
05B-1	CA1N05B000	8	-	5.00	7.10	3.00	2.31	-	8.20	11.70	0.20	5.90	
06B-1	CA1N06B000	9.525	3/8"	6.35	8.20	5.72	3.28	-	13.15	16.80	0.41	10.40	
08B	CA1N08B000	12.70	1/2"	7.75	10.10	4.90	4.09	-	12.60	14.10	0.49	13.50	
08B-1	CA1N08B000	12.70	1/2"	8.51	11.80	7.75	4.46	-	17.00	20.90	0.68	18.00	
10B-1	CA1N10B000	15.875	5/8"	10.16	14.70	9.65	5.08	-	19.60	23.70	0.91	22.40	
12B-1	CA1N12B000	19.05	3/4"	12.07	16.10	11.68	5.72	-	22.70	27.30	1.12	29.00	
16B-1	CA1N16B000	25.40	1"	15.88	21.00	17.02	8.27	-	36.10	41.50	2.64	60.00	
20B-1	CA1N20B000	31.75	1 1/4"	19.05	26.40	19.56	10.19	-	43.20	49.30	3.68	95.00	
24B-1	CA1N24B000	38.10	1 1/2"	25.40	33.40	25.40	14.63	-	53.10	59.70	7.05	160.00	
28B-1	CA1N28B000	44.45	1 3/4"	27.94	37.00	30.99	15.90	-	65.10	72.50	8.96	200.00	
32B-1	CA1N32B000	50.80	2"	29.21	42.20	30.99	17.81	-	63.60	71.50	10.00	250.00	
40B-1	CA1N40B000	63.50	2 1/2"	39.37	52.90	38.10	22.89	-	79.00	91.00	16.20	355.00	
48B-1	CA1N48B000	76.20	3"	48.26	63.80	47.70	29.22	-	98.60	110.60	24.93	560.00	

DUPLEX													
ISO	SEDIS reference	P mm	P inch	D1	H max	L1 min	D2	P2	L2	L3	Kg/m	UTS min (kN)	
05B-2	CA2N05B000	8	-	5.00	7.11	3.00	2.31	5.64	14.30	17.40	0.38	7.95	
06B-2	CA2N06B000	9.525	3/8"	6.35	8.20	5.72	3.28	10.24	23.80	27.10	0.77	18.70	
08B2	CA2N08B000	12.70	1/2"	8.51	11.80	7.75	4.46	13.92	31.00	34.90	1.35	32.00	
10B-2	CA2N10B000	15.875	5/8"	10.16	14.70	9.65	5.08	16.59	36.20	40.30	1.79	44.50	
12B-2	CA2N12B000	19.05	3/4"	12.07	16.10	11.68	5.72	19.46	42.20	46.80	2.22	57.80	
16B-2	CA2N16B000	25.40	1"	15.88	21.00	17.02	8.27	31.88	68.00	73.40	5.13	114.70	
20B-2	CA2N20B000	31.75	1 1/4"	19.05	26.40	19.56	10.19	36.45	79.00	85.10	7.72	170.00	
24B-2	CA2N24B000	38.10	1 1/2"	25.40	33.40	25.40	14.63	48.36	101.80	108.40	13.85	280.00	
28B-2	CA2N28B000	44.45	1 3/4"	27.94	37.00	30.99	15.90	59.56	124.70	132.10	18.80	360.00	
32B-2	CA2N32B000	50.80	2"	29.21	42.20	30.99	17.81	58.55	126.00	133.90	19.80	450.00	
40B-2	CA2N40B000	63.50	2 1/2"	39.37	52.90	38.10	22.89	72.29	154.90	166.90	32.08	630.00	
48B-2	CA2N48B000	76.20	3"	48.26	63.80	47.70	29.22	91.21	189.50	201.50	49.50	1 000.00	

TRIPLEX													
ISO	SEDIS reference	P mm	P inch	D1	H max	L1 min	D2	P2	L2	L3	Kg/m	UTS min (kN)	
06B-3	CA3N06B000	9.525	3/8"	6.35	8.20	5.72	3.28	10.24	34.00	37.30	1.16	30.10	
08B-3	CA3N08B000	12.70	1/2"	8.51	11.80	7.75	4.46	13.92	44.90	48.80	2.03	47.50	
10B-3	CA3N10B000	15.875	5/8"	10.16	14.70	9.65	5.08	16.59	52.80	56.90	2.68	66.70	
12B-3	CA3N12B000	19.05	3/4"	12.07	16.10	11.68	5.72	19.46	61.70	66.30	3.39	86.70	
16B-3	CA3N16B000	25.40	1"	15.88	21.00	17.02	8.27	31.88	99.90	105.30	7.80	170.50	
20B-3	CA3N20B000	31.75	1 1/4"	19.05	26.40	19.56	10.19	36.45	116.00	122.10	11.53	250.00	
24B-3	CA3N24B000	38.10	1 1/2"	25.40	33.40	25.40	14.63	48.36	150.20	156.80	20.31	425.00	
28B-3	CA3N28B000	44.45	1 3/4"	27.94	37.00	30.99	15.90	59.56	184.60	192.00	28.00	530.00	
32B-3	CA3N32B000	50.80	2"	29.21	42.20	30.99	17.81	58.55	184.50	192.40	29.60	670.00	
40B-3	CA3N40B000	63.50	2 1/2"	39.37	52.90	38.10	22.89	72.29	227.20	239.20	47.96	950.00	
48B-3	CA3N48B000	76.20	3"	48.26	63.80	47.70	29.22	91.21	280.30	292.30	80.20	1 500.00	

CONNECTING LINKS

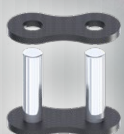

RIVETED LINK
REF : 005



SPRING CLIP
CONNECTING LINK
REF : 006



COTTERED
CONNECTING LINK
REF : 008

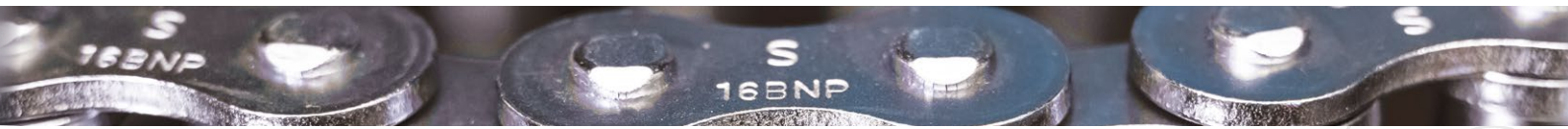

WAISTED PLATES NICKEL PLATED CHAINS

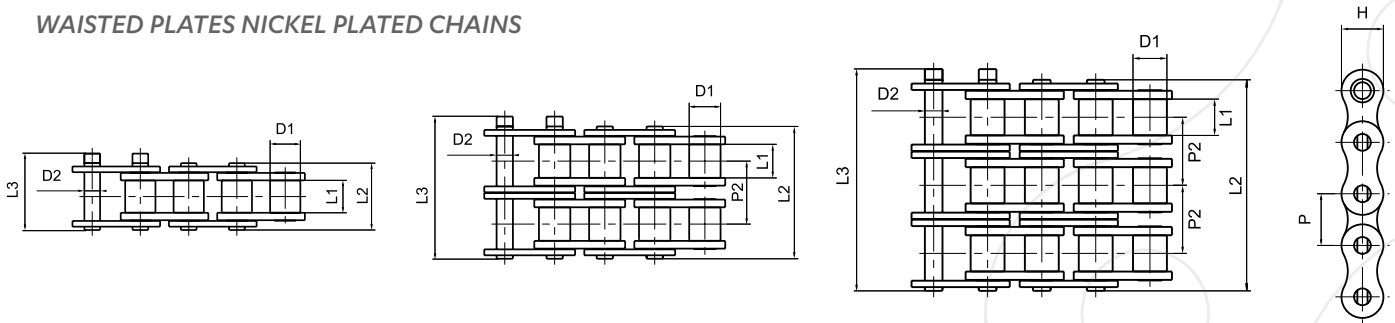

Dimensions in mm

SIMPLEX												
ISO	SEDIS reference	P mm	P inch	D1	H max	L1 min	D2	P2	L2	L3	Kg/m	UTS min (kN)
05B-1	CN1W05B000	8	-	5.00	7.10	3.00	2.31	-	8.20	11.70	0.18	5.90
06B-1	CN1W06B000	9.525	3/8"	6.35	8.20	5.72	3.28	-	13.15	16.80	0.58	10.40
08B-1	CN1W08B000	12.70	1/2"	8.51	11.80	7.75	4.46	-	17.00	20.90	0.68	18.00
10B-1	CN1W10B000	15.875	5/8"	10.16	14.70	9.65	5.08	-	19.60	23.70	0.84	22.40
12B-1	CN1W12B000	19.05	3/4"	12.07	16.10	11.68	5.72	-	22.70	27.30	1.14	29.00
16B-1	CN1W16B000	25.40	1"	15.88	21.00	17.02	8.27	-	36.10	41.50	2.72	60.00

DUPLEX												
ISO	SEDIS reference	P mm	P inch	D1	H max	L1 min	D2	P2	L2	L3	Kg/m	UTS min (kN)
06B-2	CN2W06B000	9.525	3/8"	6.35	8.20	5.72	3.28	10.24	23.80	27.10	0.68	18.70
08B-2	CN2W08B000	12.70	1/2"	8.51	11.80	7.75	4.46	13.92	31.00	34.90	1.34	32.00
10B-2	CN2W10B000	15.875	5/8"	10.16	14.70	9.65	5.08	16.59	36.20	40.30	1.93	44.50
12B-2	CN2W12B000	19.05	3/4"	12.07	16.10	11.68	5.72	19.46	42.20	46.80	2.35	57.80
16B-2	CN2W16B000	25.40	1"	15.88	21.00	17.02	8.27	31.88	68.00	73.40	5.28	114.70

STRAIGHT SIDE PLATES NICKEL PLATED CHAINS

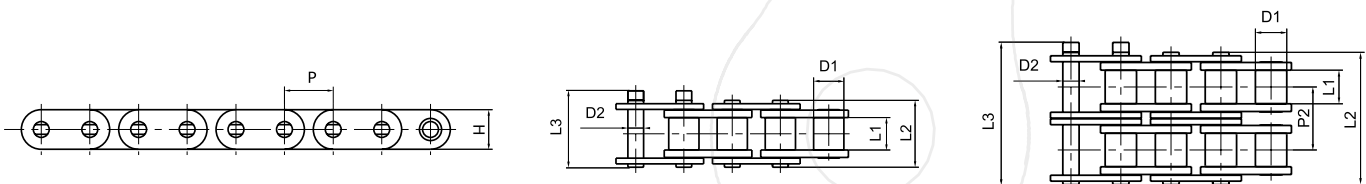

Dimensions in mm

SIMPLEX												
ISO	SEDIS reference	P mm	P inch	D1	H max	L1 min	D2	L2	L3	Kg/m	UTS min (kN)	
08B-1	CCN1N08B000	12.70	1/2"	8.51	11.80	7.75	4.45	16.60	18.10	0.78	17.80	
10B-1	CCN1N10B000	15.875	5/8"	10.16	14.70	9.65	5.08	19.00	20.50	0.96	22.20	
12B-1	CCN1N12B000	19.05	3/4"	12.07	16.10	11.68	5.72	22.30	23.80	1.14	29.00	
16B-1	CCN1N16B000	25.40	1"	15.88	21.00	17.02	8.27	36.10	41.50	2.99	60.00	

DUPLEX												
ISO	SEDIS reference	P mm	P inch	D1	H max	L1 min	D2	L2	L3	Kg/m	UTS min (kN)	
08B-2	CCN2N08B000	12.70	1/2"	8.51	11.80	7.75	4.45	31.00	34.90	1.32	32.00	
10B-2	CCN2N10B000	15.875	5/8"	10.16	14.70	9.65	5.08	36.20	40.30	1.66	44.50	
12B-2	CCN2N12B000	19.05	3/4"	12.07	16.10	11.68	5.72	42.20	46.80	2.29	57.80	
16B-2	CCN2N16B000	25.40	1"	15.88	21.00	17.02	8.27	68.00	73.40	5.89	114.70	

CRANKED LINKS



SINGLE CRANK LINK
REF : 016



DOUBLE CRANK LINK
REF : 021

STAINLESS STEEL ROLLER CHAINS

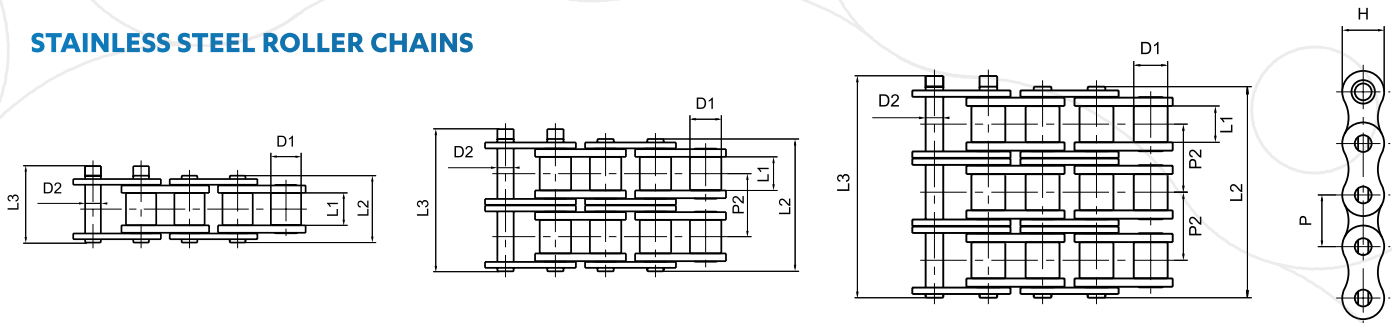

304 STAINLESS STEEL EUROPEAN SERIES ROLLER CHAINS

Dimensions in mm

SIMPLEX												
Ref	SEDIS reference	P mm	P inch	D1	H max	L1 min	D2	P2	L2	L3	Kg/m	UTS min (kN)
06B-1	CI1N06B000	9.525	3/8"	6.35	8.20	5.72	3.28	-	13.50	16.80	0.44	6.65
08B-1	CI1N08B000	12.70	1/2"	8.51	11.80	7.75	4.45	-	17.00	20.90	0.70	12.00
10B-1	CI1N10B000	15.875	5/8"	10.16	14.70	9.65	5.08	-	19.60	23.70	0.92	15.00
12B-1	CI1N12B000	19.05	3/4"	12.07	16.10	11.68	5.72	-	22.70	27.30	1.12	17.00
16B-1	CI1N16B000	25.40	1"	15.88	21.00	17.02	8.27	-	36.10	41.50	2.59	40.00

DUPLEX												
Ref	SEDIS reference	P mm	P inch	D1	H max	L1 min	D2	P2	L2	L3	Kg/m	UTS min (kN)
06B-2	CI2N06B000	9.525	3/8"	6.35	8.20	5.72	3.28	10.24	23.8	27.1	0.74	10.50
08B-2	CI2N08B000	12.70	1/2"	8.51	11.80	7.75	4.45	13.92	31	34.9	1.40	22.00
10B-2	CI2N10B000	15.875	5/8"	10.16	14.70	9.65	5.08	16.59	36.2	40.3	3.00	28.45
12B-2	CI2N12B000	19.05	3/4"	12.07	16.10	11.68	5.72	19.46	42.2	46.8	2.21	37.25
16B-2	CI2N16B000	25.40	1"	15.88	21.00	17.02	8.27	31.88	68	73.4	5.08	74.45

TRIPLEX												
Ref	SEDIS reference	P mm	P inch	D1	H max	L1 min	D2	P2	L2	L3	Kg/m	UTS min (kN)
06B-3	CI3N06B000	9.525	3/8"	6.35	8.20	5.72	3.28	10.24	34	37.3	1.11	17.85
08B-3	CI3N08B000	12.70	1/2"	8.51	11.80	7.75	4.45	13.92	44.9	48.8	1.31	35.30
10B-3	CI3N10B000	15.875	5/8"	10.16	14.70	9.65	5.08	16.59	52.8	56.9	1.79	42.65
12B-3	CI3N12B000	19.05	3/4"	12.07	16.10	11.68	5.72	19.46	61.7	66.3	2.22	50.05
16B-3	CI3N16B000	25.40	1"	15.88	21.00	17.02	8.27	31.88	99.9	105.3	5.03	117.65

304 STAINLESS STEEL AMERICAN SERIES ROLLER CHAINS

SIMPLEX												
Ref	SEDIS reference	P mm	P inch	D1	H max	L1 min	D2	P2	L2	L3	Kg/m	UTS min (kN)
40-1	CI1N040000	12.70	1/2"	7.97	12.00	7.85	3.93	-	11.25	16.30	0.59	10.30
50-1	CI1N050000	15.875	5/8"	10.16	15.00	9.66	5.04	-	13.90	20.40	0.96	17.00
60-1	CI1N060000	19.05	3/4"	11.95	18.00	12.65	5.91	-	17.81	25.40	1.39	23.30

STRAIGHT SIDED EUROPEAN SERIES ROLLER CHAINS

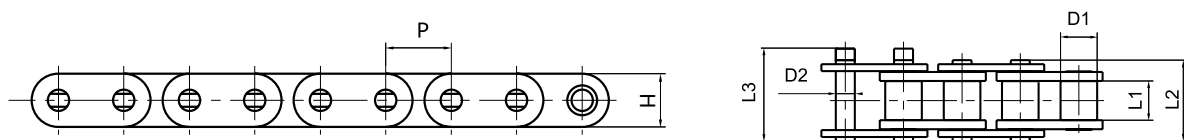

Dimensions in mm

SIMPLEX												
Ref	SEDIS reference	P mm	P inch	D1	H max	L1 min	D2	L2	L3	Kg/m	UTS min (kN)	
06B-1	CC1N06B000	9.525	3/8"	6.35	8.20	5.72	3.28	13.15	16.80	0.41	10.40	
08B-1	CC1N08B000	12.70	1/2"	8.51	11.80	7.75	4.45	16.60	18.10	0.72	17.80	
10B-1	CC1N10B000	15.875	5/8"	10.16	14.70	9.65	5.08	19.00	20.50	0.96	22.20	
12B-1	CC1N12B000	19.05	3/4"	12.07	16.10	11.68	5.72	22.30	23.80	1.25	29.00	
16B-1	CC1N16B000	25.40	1"	15.88	21.00	17.02	8.27	36.10	41.50	3.34	60.00	

sedis 

murugappa



RECORD

RECORD® a brand of **sedis** 

November 2019 – Pictures: Olivier Frajman

6 rue Nicolas Siret , CS 90104, 10003 TROYES Cedex – France

Tél. : +33 (0) 3 25 76 29 50 • Fax : +33 (0) 3 25 80 31 62 • email: <https://sedis.com/contact> • www.sedis.com