

KATALOG



Industriekomponenten

***WAHRHAFTES STÄRKE
IN EINER WELT IM
STETIGEN WECHSEL***

ROLLENKETTEN UND SPEZIALKETTEN



Rollenketten SEDIS ROLMOR	8
Ketten für Stau- und Förderbetrieb	9

KETTENSCHANNELEMENTE



Elastische Spannarme - Typ BT / BTF / BTP	12
Bügel für Spannelemente - Typ SBT	13
Kettenspannräder mit Kugellager	14
Kettenspannräder mit abgedichtetem Kugellagern - Typ TR (Gefräste Wellen)	15
Kettenspannräder mit abgedichtetem Kugellager - Typ TF	16
PET-Kettengleiter: Zubehör Typ OVR	17
Spannrollen: Zubehör Typ RLP und RLA	18
Keilriemenscheiben: Zubehör Typ KSP	19
Axiale Spannvorrichtungen TAS	20
Set für axiale Spannvorrichtungen - PET-Kettengleiter - Typ PF	21
Axiale Spannvorrichtungen TAD	22
Set für axiale Spannvorrichtungen - PET-Kettengleiter - Typ PG	23
Komplette axiale Spannvorrichtungen TAD + Kettengleiter PG	24
Axiale Spannvorrichtungen TBD	25
Set für axiale Spannvorrichtungen - PET-Kettengleiter - Typ PC	26
Set für axiale Spannvorrichtungen - PET-Kettengleiter - Typ PV	26
Komplette axiale Spannvorrichtungen TBD + Kettengleiter PC	27
Komplette axiale Spannvorrichtungen TBD + Kettengleiter PV	28
Axiale Spannvorrichtungen TCD	29
Set für axiale Spannvorrichtungen - PET-Kettengleiter - Typ QG	30
Set für axiale Spannvorrichtungen - PET-Kettengleiter - Typ QV	30
Komplette axiale Spannvorrichtungen TCD + Kettengleiter QG	31
Komplette axiale Spannvorrichtungen TCD + Kettengleiter QV	32
Technische Daten - Montagebeispiele	33

KETTEN- UND RIEMENFÜHRUNGEN

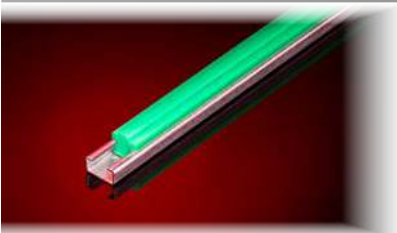

Kettenführungen	36
Riemenführungen	42
„C“-Profil für Kettenführungen	43

SCHARNIERBANDKETTEN



Geradegängig	46
Kurvengängig	47
Kettenräder für Scharnierbandketten	49

KETTENRÄDER, KETTENRADSCHLEIBEN UND GUSSRÄDER



Vorgebohrte Kettenräder Stahl / Edelstahl	52
Vorgebohrte Kettenradscheiben	64
Kettenräder Stahl für Klemmbuchsen	78
Vorgebohrte Gussräder	82
Gussräder für Klemmbuchsen	85
Klemmbuchsen	88
Vorgebohrte Kettenräder mit gehärteten Zähnen	89
Montagefertige Kettenräder	95
Zweifach Kettenradscheiben für 2 Einfach Rollenketten	101
Technische Daten	103
Typische Abmessungen von Keilnuten	103

KEILRIEMENSCHLEIBEN



Verstellbar Keilriemenscheiben	106
--------------------------------	-----

VORGEBOHRTE KEILRIEMENSCHLEIBEN

Z-Profil / SPZ mit Vollnaben	107
A-Profil / SPA mit Vollnaben	108
B-Profil / SPB mit Vollnaben	110
C-Profil / SPC mit Vollnaben	112

KEILRIEMENSCHLEIBEN FÜR KLEMMBUCHSEN

Z-Profil / SPZ für Klemmbuchsen	113
A-Profil / SPA für Klemmbuchsen	115
B-Profil / SPB für Klemmbuchsen	117
C-Profil / SPC für Klemmbuchsen	119

KEILRIEMENSCHLEIBEN FÜR SPANNSÄTZE

A-Profil / SPA für Spannsätze	121
B-Profil / SPB für Spannsätze	123
C-Profil / SPC für Spannsätze	125

ZAHNRIEMENSCHLEIBEN



ZAHNRIEMENSCHLEIBEN MIT VOLLNABE VORGEBOHRT

Metrisch Aluminium Typ T	128
Metrisch Aluminium Typ ST	130
Inch Typ XL	132
Inch Typ L	133
Inch Typ H - XH - XXH	134
HTD 3M	138
HTD 5M	138
HTD 8M	139
HTD 14M	141

ZAHNRIEMENSCHLEIBEN FÜR KLEMMBUCHSEN

Inch Typ L	143
Inch Typ H	144
HTD 5M	146
HTD 8M für Klemmbuchsen	147
HTD 14M für Klemmbuchsen	149

ZAHNWELLEN

Zahnwellen Aluminium Metrisch Typ T	154
Zahnwellen Aluminium Metrisch Typ ST	155
Zahnwellen Inch Typ MXL, XL, L	156
Zahnwellen Typ „HTD“	157

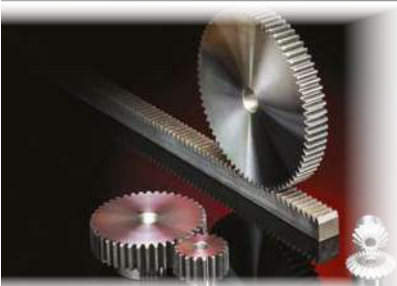
ZAHNRÄDER UND ZAHNSTANGEN

Zahnräder mit seitlicher Nabe	160
Vorgebohrte Zahnräder mit seitlicher Nabe	164
Zahnräder ohne Nabe	166
Zahnstangen aus Vierkantstahl	168
Technische Daten	169

KEGELRÄDER

Kegelräder mit geraden Zähnen Typ A	172
Kegelräder mit geraden Zähnen Typ B	174

SPANNSÄTZE

Montagegrundlagen	178
Spannsätze	180

KUPPLUNGEN

Sternkupplungen	190
Drehelastische HRC-Kupplungen	192
Flexible Kupplungen	193

ZUBEHÖR

Naben	196
Motorspannschienen	198
Klemmringe	199

sedis 





ROLLENKETTEN UND SPEZIALKETTEN



ROLLENKETTEN SEDIS ROLMOR®



Speziell entwickelt für die Hersteller von Antriebs- oder leichten Fördersystemen bieten Sedis ROLMOR Ketten die passende Lösung zur Optimierung der Herstellkosten.

Sie entsprechen der Norm ISO 606 und haben ein ausgezeichnetes Preis-Leistungsverhältnis.

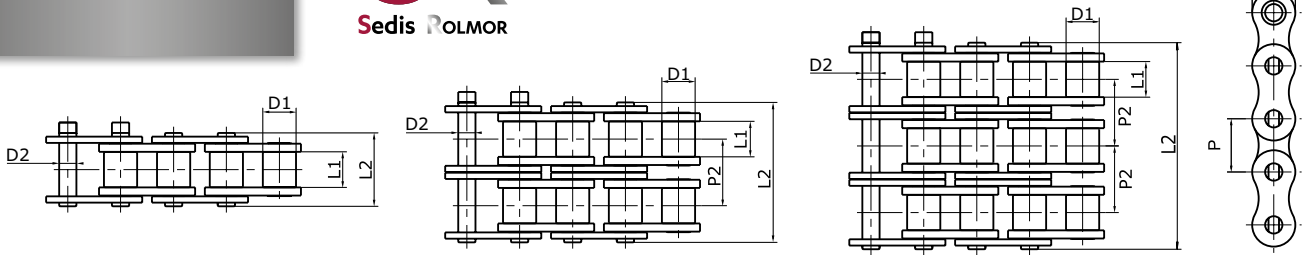

EINFACH												
ISO	Art. Nr.	P mm	P Inch	D1	H maxi	L1 mini	D2	P2	L2	Kg/m	Rr (kN mini)	Edelstahl serie
03B-1	CA1W03B000	5	-	3,20	4,10	2,50	1,49	-	7,40	0,08	2,20	-
06B-1	CA1Y06B000	9,525	3/8"	6,35	8,26	5,72	3,28	-	13,15	0,41	9,00	CI1Y06B000
-	CA1WV6000	12,7	1/2"	7,75	10,90	6,40	4,18	-	14,50	0,52	15,75	-
081	CA1Y081000	12,7X3,3	1/2"x1/8"	7,75	10,50	3,48	3,68	-	9,50	0,30	8,20	-
08B-1	CA1Y08B000	12,7	1/2"	8,51	11,81	7,75	4,45	-	16,95	0,69	18,00	CI1Y08B000
10B-1	CA1Y10B000	15,875	5/8"	10,16	14,73	9,65	5,08	-	19,50	0,93	22,40	CI1Y10B000
12B-1	CA1Y12B000	19,05	3/4"	12,07	16,13	11,68	5,72	-	22,50	1,15	29,00	CI1Y12B000
16B-1	CA1Y16B000	25,4	1"	15,88	21,08	17,02	8,28	-	36,10	2,71	60,00	CI1Y16B000
20B-1	CA1Y20B000	31,75	1" 1/4	19,05	26,42	19,58	10,19	-	42,40	3,70	95,00	-
24B-1	CA1Y24B000	38,1	1" 1/2	25,40	33,40	25,40	14,63	-	53,40	7,10	160,00	-
28B-1	CA1Y28B000	44,45	1" 3/4	27,94	37,08	30,99	15,90	-	65,10	8,50	200,00	-
32B-1	CA1Y32B000	50,8	2"	29,21	42,29	30,99	17,81	-	66,00	10,25	250,00	-
40B-1	CA1Y40B000	63,5	2" 1/2	39,37	52,96	38,10	22,89	-	82,60	16,35	355,00	-
48B-1	CA1Y48B000	76,2	3"	48,26	63,88	45,72	29,24	-	99,10	25,00	560,00	-

ZWEIFACH												
ISO	Art. Nr.	P mm	P Inch	D1	H maxi	L1 mini	D2	P2	L2	Kg/m	Rr (kN mini)	Edelstahl serie
06B-2	CA2Y06B000	9,525	3/8"	6,35	8,26	5,72	3,28	10,24	23,40	0,74	16,90	CI2Y06B000
08B-2	CA2Y08B000	12,7	1/2"	8,51	11,81	7,75	4,45	13,92	31,00	1,34	32,00	CI2Y08B000
10B-2	CA2Y10B000	15,875	5/8"	10,16	14,73	9,65	5,08	16,59	36,10	1,84	44,50	-
12B-2	CA2Y12B000	19,05	3/4"	12,07	16,13	11,68	5,72	19,46	42,00	2,31	57,80	CI2Y12B000
16B-2	CA2Y16B000	25,4	1"	15,88	21,08	17,02	8,28	31,88	68,00	5,42	106,00	-
20B-2	CA2Y20B000	31,75	1" 1/4	19,05	26,42	19,58	10,19	36,45	79,70	7,20	170,00	-
24B-2	CA2Y24B000	38,1	1" 1/2	25,40	33,40	25,40	14,63	48,36	101,80	13,40	280,00	-
28B-2	CA2Y28B000	44,45	1" 3/4	27,94	37,08	30,99	15,90	59,56	124,70	16,60	360,00	-
32B-2	CA2Y32B000	50,8	2"	29,21	42,29	30,99	17,81	58,55	124,60	21,00	450,00	-
40B-2	CA2Y40B000	63,5	2" 1/2	39,37	52,96	38,10	22,89	72,29	154,90	32,00	630,00	-
48B-2	CA2Y48B000	76,2	3"	48,26	63,88	45,72	29,24	91,21	190,40	50,00	1000,00	-

DREIFACH												
ISO	Art. Nr.	P mm	P Inch	D1	H maxi	L1 mini	D2	P2	L2	Kg/m	Rr (kN mini)	Edelstahl serie
06B-3	CA3Y06B000	9,525	3/8"	6,35	8,26	5,72	3,28	10,24	33,50	1,16	24,90	-
08B-3	CA3Y08B000	12,7	1/2"	8,51	11,81	7,75	4,45	13,92	44,90	2,03	47,50	-
10B-3	CA3Y10B000	15,875	5/8"	10,16	14,73	9,65	5,08	16,59	52,70	2,77	66,70	-
12B-3	CA3Y12B000	19,05	3/4"	12,07	16,13	11,68	5,72	19,46	61,50	3,46	86,70	-
16B-3	CA3Y16B000	25,4	1"	15,88	21,08	17,02	8,28	31,88	99,80	8,13	160,00	-
20B-3	CA3Y20B000	31,75	1" 1/4	19,05	26,42	19,58	10,19	36,45	114,44	10,82	250,00	-
24B-3	CA3Y24B000	38,1	1" 1/2	25,40	33,40	25,40	14,63	48,36	150,20	13,40	425,00	-
28B-3	CA3Y28B000	44,45	1" 3/4	27,94	37,08	30,99	15,90	59,56	184,30	24,92	530,00	-
32B-3	CA3Y32B000	50,8	2"	29,21	42,29	30,99	17,81	58,55	183,20	31,56	670,00	-
40B-3	CA3Y40B000	63,5	2" 1/2	39,37	52,96	38,10	22,89	72,29	227,20	48,10	950,00	-
48B-3	CA3Y48B000	76,2	3"	48,26	63,88	45,72	29,24	91,21	281,60	75,00	1500,00	-



Nietglied
Bez.: 005



Federverschlussglied
Bez.: 6



Splintverschlussglied
Bez.: 8



Einfach gekröpftes
Verbindungsstück mit Splint
Bez.: 16



gekröpftes Doppelglied
Bez.: 021



KETTEN FÜR STAU- UND FÖRDERBETRIEB

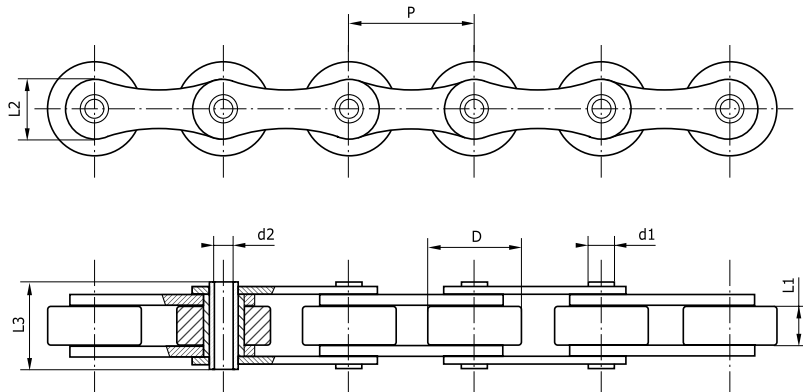

KETTEN MIT HOHLBOLZEN									
Art. Nr.	P mm	P Inch	L1 mini	D	d2	L2	L3	Kg/m	Rr (kN mini)
MLE 50	50	1,97"	10	30	8,3	26	28,5	2,07	50
MLB 50,8	50,8	2"	10	30	8,3	26	28,5	2,07	50

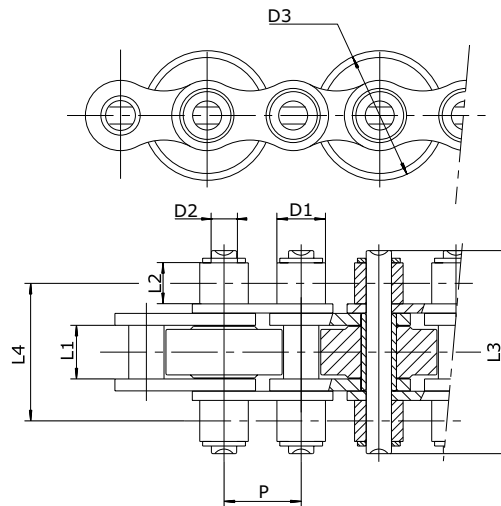

STAURÖLLENKETTEN											
Art. Nr.	P mm	P Inch	L1 mini	L2	D1	D2	L3	L4	D3	Kg/m	Rr (kN mini)
CAB12 D24	19,05	3/4"	11,68	7,50	12,07	5,72	42,70	31,50	24	2,52	28,90
CAB12 D26	19,05	3/4"	11,68	7,50	12,07	5,72	42,70	31,50	26	2,52	28,90
CAB16 D38,5	25,40	1"	17,02	12,50	15,88	8,28	65,26	45,00	38,5	6,63	60

sedis 



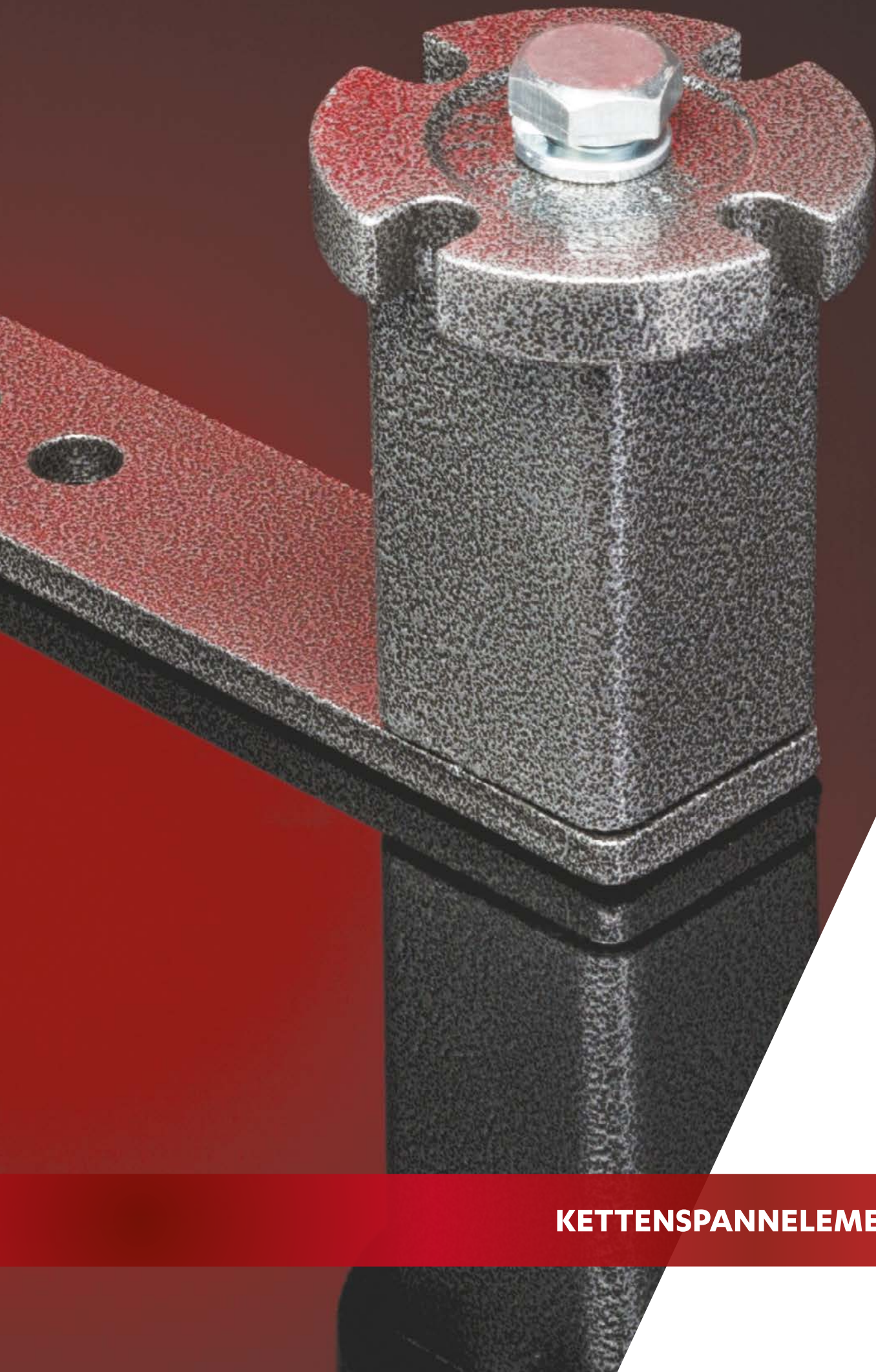

KETTENSCHANNELEMENTE



SPANNELEMENT - TYP BT

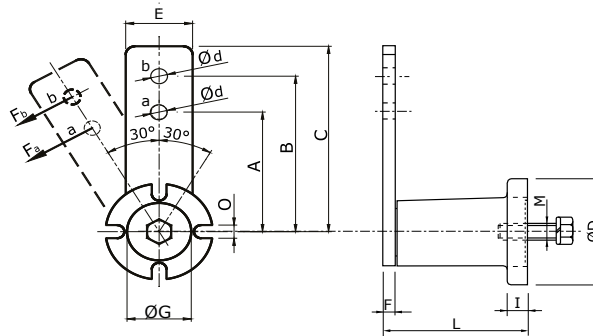

Art. Nr.	A	B	C	ØD	Ød	E	F	ØG	I	L	M	O	Fa. Pos. a [N]	Fb. Pos. b [N]	Kg
BT 11	60	80	90	40	8,5	25	5	20	6	50	M6	7	0-113	0-85	0,28
BT 15	80	100	112,5	50	10,5	30	5	30	8	62	M8	9	0-170	0-136	0,48
BT 18	80	100	115	60	10,5	35	6	35	10	76	M10	9	0-425	0-340	0,73
BT 27	100	130	155	80	12,5	50	8	48	15	105	M12	11	0-1027	0-790	2,00
BT 38	140	175	205	100	20,5	65	10	62	15	136	M16	13	0-2000	0-1600	4,20
BT 45	180	225	260	120	20,5	80	12	80	18	196	M20	13	0-3190	0-2550	7,00
BT 50	200	250	290	130	20,5	90	20	78	20	210	M24	17	0-4950	0-3950	9,60

Gefederter Ausleger Typ BT aus Stahlguss mit Epoxidfarbe beschichtet. Alternativ in verzinktem Stahl, Nickelstahl oder Edelstahl erhältlich (BT 11 bis BT 38. Wir beraten Sie gerne bezüglich weiterer Abmessungen).

Torsionswinkel + / - 30°C - Betriebstemperatur - 40°C bis + 80°C

Fa.: Durch die Spannvorrichtung einwirkende Kraft bei Positionierung des Sets in Bohrung a

Fb.: Durch die Spannvorrichtung einwirkende Kraft bei Positionierung des Sets in Bohrung b

SPANNELEMENT - TYP BTF

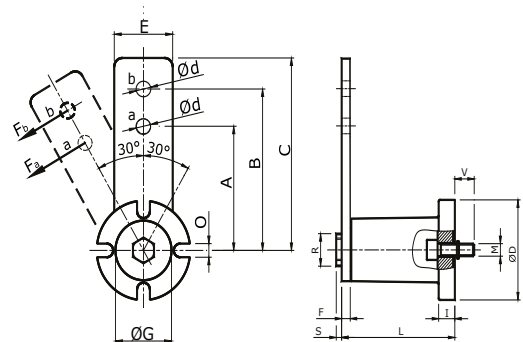
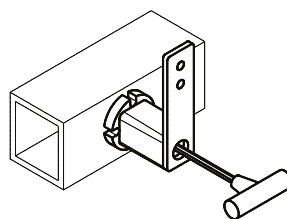

Art. Nr.	A	B	C	ØD	Ød	E	F	ØG	I	L	M	O	ØR	S	V	Fa. Pos. a [N]	Fb. Pos. b [N]	Kg
BTF 11	60	80	90	40	8,5	25	5	20	6	50	M5	7	14	3,5	10	0-113	0-85	0,25
BTF 15	80	100	112,5	50	10,5	30	5	30	8	62	M6	9	20	5	14	0-170	0-136	0,45
BTF 18	80	100	115	60	10,5	35	6	35	10	76	M8	9	20	5	19	0-425	0-340	0,69
BTF 27	100	130	155	80	12,5	50	8	48	15	105	M10	11	26	5	18	0-1027	0-790	1,90
BTF 38	140	175	205	100	20,5	65	10	62	15	136	M12	13	35	6	20	0-2000	0-1600	3,90
BTF 45	180	225	260	120	20,5	80	12	80	18	196	M16	13	40	6	36	0-3190	0-2550	6,90
BTF 50	200	250	290	130	20,5	90	20	78	20	210	M20	17	40	6	25	0-4950	0-3950	9,50

Torsionswinkel + / - 30°C - Betriebstemperatur - 40°C bis + 80°C - Befestigung vorne mit Innengewinde „M“

Fa.: Durch die Spannvorrichtung einwirkende Kraft bei Positionierung des Sets in Bohrung a

Fb.: Durch die Spannvorrichtung einwirkende Kraft bei Positionierung des Sets in Bohrung b



SPANNELEMENT AUS KUNSTSTOFF - TYP BTP



Die BTP-Spannvorrichtungen eignen sich ideal für den Transport in feuchter oder ätzender Umgebung.

Die BTP-Spannvorrichtungen werden aus Kunststoff hergestellt, mit Einlagen aus Metall. Der Typ BTP verfügt über eine zusätzliche Verstärkungsschraube.

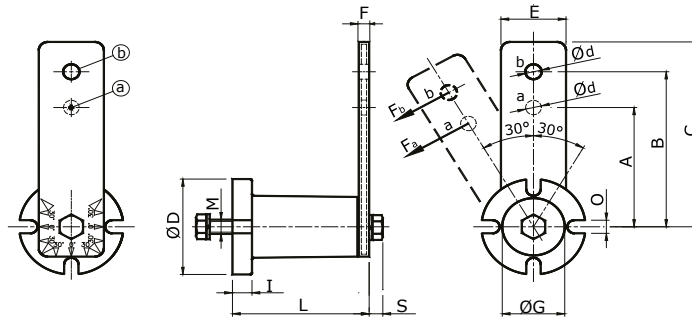

Art. Nr.	A	B	C	ØD	Ød	E	F	ØG	I	L	M	O	S	Fa. Pos. a [N]	Fb. Pos. b [N]	Kg
BTP 11	60	80	90	40	8,5	24	7	20	6	52	M6x20	7	7,5	0-113	0-85	0,10
BTP 15	80	100	112,5	50	10,5	30	8	30	8	66	M8x25	9	9,2	0-170	0-136	0,20
BTP 18	80	100	115	60	10,5	36	8	35	10	79	M10x30	9	10,5	0-425	0-340	0,26
BTP 27	100	130	155	80	12,5	50	10	48	15	108	M12x40	11	10,5	0-1027	0-790	0,72

Torsionswinkel + / - 30°C - Betriebstemperatur - 10°C bis + 80°C

Fa.: Durch die Spannvorrichtung einwirkende Kraft bei Positionierung des Sets in Bohrung a

Fb.: Durch die Spannvorrichtung einwirkende Kraft bei Positionierung des Sets in Bohrung b

BÜGEL FÜR SPANNELEMENTE - TYP SBT



Die SBT-Stütze wird verwendet, um die Montage elastischer Elemente auf einer Maschine zu erleichtern.

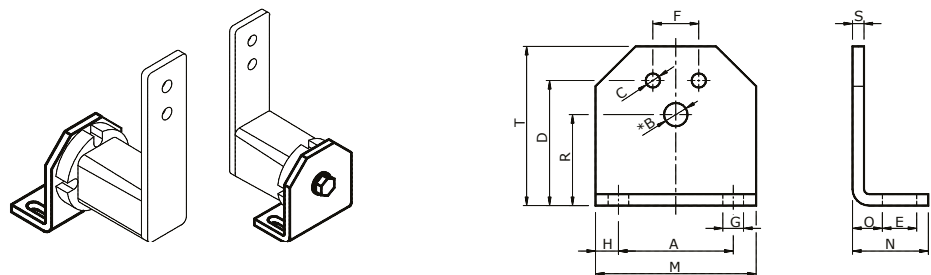

Größe																
Art. Nr.	A	B*	C	D	E	F	G	H	M	N	O	R	S	T	Kg	
SBT 11	30	11	6,5	5,5	35	13	10	7	7,5	45	30	11,5	27	4	46	0,09
SBT 15	40	15	8,5	6,5	44	13	12	7	7,5	55	32	13,5	34	5	58	0,17
SBT 18	50	18	10,5	8,5	55	15,5	20	9,5	10	70	38	16,5	43	6	74	0,29
SBT 27	65	27	12,5	10,5	75	21,5	25	11,5	12,5	90	52	21	57	8	98	0,72
SBT 38	80	38	16,5	12,5	85	24	35	14	15	110	55	21	66	8	116	0,93
SBT 45	100	45	20,5	12,5	110	30	40	18	20	140	66	26	80	10	140	1,82

* Bohrung B wird für die Befestigung von elastischen Spannarmen des Typs BT und BTF verwendet.



KETTENSCHANNRÄDER MIT KUGELLAGER

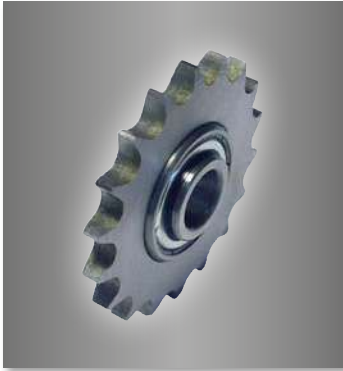

Die präzise Bearbeitung und Montage der abgedichteten Kugellager verleihen unseren Produkten ausgezeichneten Widerstand gegen Belastung und Verschleiß.

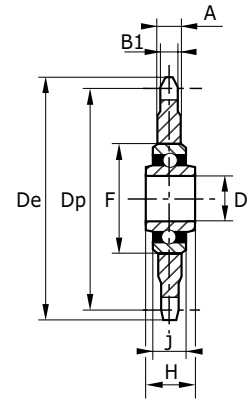
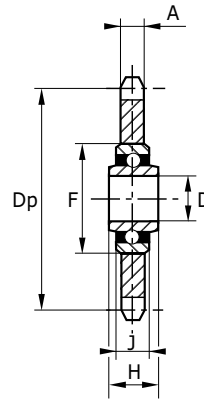
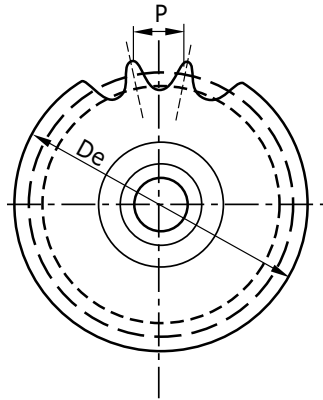

Maß (mm)	Maß (Inch)	Ketten	Art. Nr.	Z	De	Dp	B1	A	D	F	H	J	Kg
8	8	05B-1	PTR05B023	23	62,00	58,75	2,8	7,0	16	40	18,3	12	0,13
9,525	3/8" x 7/32"	06B-1	PTR06B021	21	68,00	63,91	5,3	7,0	16	40	18,3	12	0,15
12,7 x 3,18	1/2" x 1/8"	081-1	PTR081018	18	78,90	73,14	3,0	7,0	16	40	18,3	12	0,18
12,7 x 4,76	1/2" x 3/16"	083-1	PTR083016	16	70,90	65,10	4,5	7,0	16	40	18,3	12	0,17
12,7 x 4,76	1/2" x 3/16"	083-1	PTR083018	18	78,90	73,14	4,5	7,0	16	40	18,3	12	0,20
12,7	1/2" x 5/16"	08B-1	PTR08B016	16	69,50	65,10	-	7,2	16	40	18,3	12	0,17
12,7	1/2" x 5/16"	08B-1	PTR08B018	18	77,80	73,14	-	7,2	16	40	18,3	12	0,22
12,7	1/2" x 5/16"	08B-1	PTR08B020	20	85,80	81,19	-	7,2	16	40	18,3	12	0,27
15,875	5/8" x 3/8"	10B-1	PTR10B013	13	73,00	66,32	-	9,1	16	40	18,3	12	0,20
15,875	5/8" x 3/8"	10B-1	PTR10B014	14	78,00	71,34	-	9,1	16	40	18,3	12	0,23
15,875	5/8" x 3/8"	10B-1	PTR10B015	15	83,00	76,36	-	9,1	16	40	18,3	12	0,27
15,875	5/8" x 3/8"	10B-1	PTR10B017	17	93,00	86,30	-	9,1	16	40	18,3	12	0,36
19,05	3/4" x 7/16"	12B-1	PTR12B013	13	87,50	79,59	-	11,1	16	40	18,3	12	0,34
19,05	3/4" x 7/16"	12B-1	PTR12B015	15	99,80	91,63	-	11,1	16	40	18,3	12	0,47
25,4	1" x 17,02	16B-1	PTR16B012	12	109,00	98,14	-	16,2	20	47	17,7	14	0,72
25,4	1" x 17,02	16B-1	PTR16B015	15	133,00	122,17	-	16,2	20	47	17,7	14	0,90
31,75	1" 1/4 x 3/4"	20B-1	PTR20B013	13	147,80	132,65	-	18,5	25	52	21	15	1,64



Abmessungen in mm

KETTENSANNRÄDER MIT ABGEDICHTETEN KUGELLAGER - TYP TR (GEFRÄSTE WELLEN)

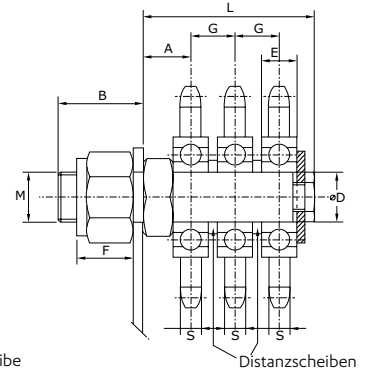
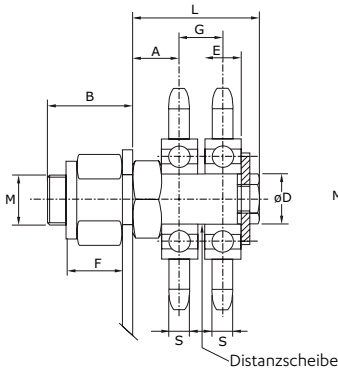
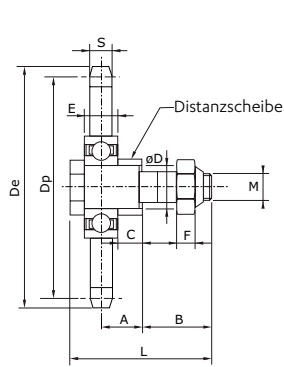

EINFACH															Größe	Kg
Art. Nr. Achse + Scheibe	Art. Nr. Einzelscheibe	Maß Kette	Z	De	Dp	S	M	D	A	B	C	E	F	L		
TR1 03B 017	PT1 03B 017	5	17	29,00	27,20	2,3	M6	6	7	15	4	6	6	28		0,100
TR1 04B 015	PT1 04B 015	6	15	31,10	28,86	2,6	M6	6	7	15	4	6	6	28	11	0,110
TR1 05B 014	PT1 05B 014	8	14	39,20	35,95	2,8	M8	8	7,5	16	4	7	8	30		0,120
TR1 06B 017	PT1 06B 017	9,525	17	55,50	51,83	5,3	M10	12	12	22	7	10	10	44		0,135
TR1 081 013	PT1 081 013	12,7 x 3,3	13	59,40	53,06	3	M10	12	12	22	7	10	10	44	15	0,140
TR1 083 013	PT1 083 013	12,7 x 4,88	13	59,40	53,06	4,5	M10	12	12	22	7	10	10	44		0,145
TR1 08B 017	PT1 08B 017	12,7	17	74,00	69,11	7,2	M12	17	15	26	9	12	12	53	18	0,280
TR1 10B 016	PT1 10B 016	15,875	16	88,30	81,37	9,1	M12	17	15	26	9	12	12	53	27	0,410
TR1 12B 014	PT1 12B 014	19,05	14	93,80	85,61	11,1	M12	17	15	26	9	13	12	53	27	0,490
TR1 16B 012	PT1 16B 012	25,4	12	109,70	98,14	16,2	M20	20	25	28	18	14	17	66	38	0,960
TR1 20B 012	PT1 20B 012	31,75	12	137,00	122,68	18,5	M24	30	40	50	30,5	19	21	115	38 - 45	2,350
TR1 24B 012	PT1 24B 012	38,1	12	161,00	147,22	24,1	M36	40	50	74	38,5	23	29	155	45 - 50	3,250

ZWEIFACH											Größe	Kg
Art. Nr. Achse + Scheibe	Maß Kette	Z	M	D	A	B	F	G	L			
TR2 06B 017	9,525	17	M12	12	12	35	10	10,24	33	27	0,235	
TR2 08B 017	12,7	17	M18	17	15	45	12	13,92	44	38	0,600	
TR2 10B 016	15,875	16	M20	17	15	45	12	16,59	46,6	38	0,900	
TR2 12B 014	19,05	14	M20	17	15	45	12	19,46	49,5	38	1,100	
TR2 16B 012	25,4	12	M24	20	24	55	14	31,88	71,8	45	2,000	

DREIFACH											Größe	Kg
Art. Nr. Achse + Scheibe	Maß Kette	Z	M	D	A	B	F	G	L			
TR3 06B 017	9,525	17	M12	12	12	35	10	10,24	43	18	0,325	
TR3 08B 017	12,7	17	M18	17	15	45	12	13,92	58	27	0,800	
TR3 10B 016	15,875	16	M20	17	15	45	12	16,59	63,2	38	1,300	
TR3 12 014	19,05	14	M20	17	15	45	12	19,46	69	38	1,600	

Schutz: Weiß verzinkt

Der Kunde kann die Bohrung im elastischen Teil gegebenenfalls vergrößern.



KETTENSCHANNRÄDER MIT ABGEDICHTETEN KUGELLAGERN - TYP TF



Kettenspannrad aus verzinktem Stahl mit abgedichtetem Kugellager - ideal zur Regelung der Spannung von Einfach-, Zweifach- und Dreifachketten.
 Maximalgeschwindigkeit 1m/s - höchste Betriebstemperatur 100°C.
 Die Sets werden mit verzinkten Schrauben geliefert.

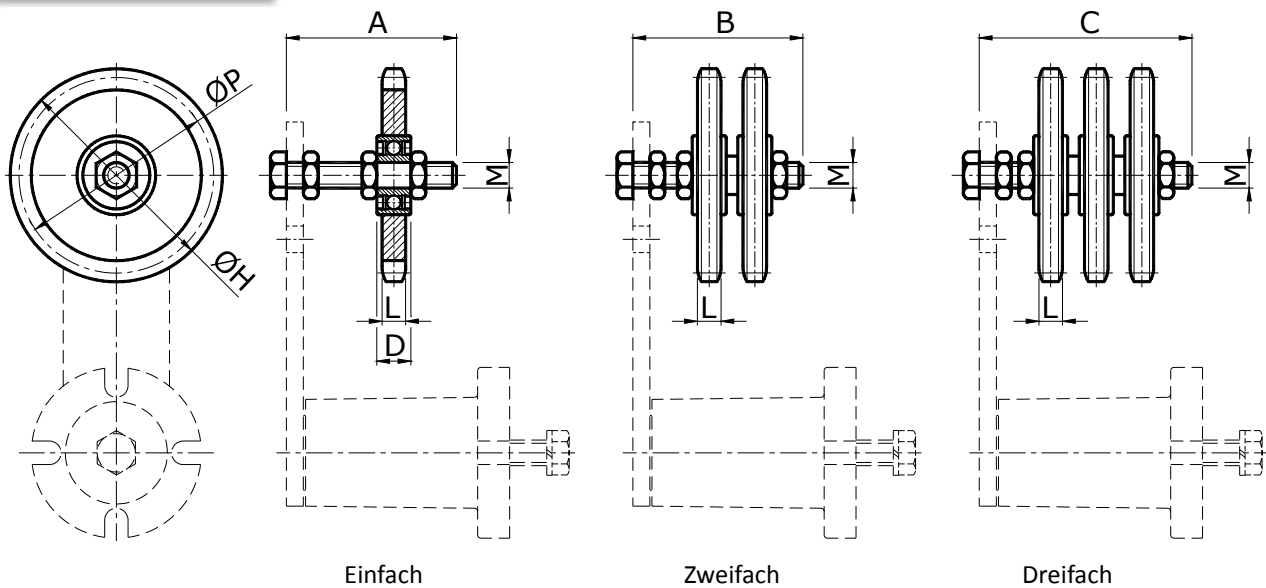

Art. Nr. Einfachkette (S)	Art. Nr. Zweifachkette (D)	Art. Nr. Dreifachkette (T)	Ketten	Größe	Z	A	B	C	D	ØH	L	M	ØP	S	Kg	
															D	T
TF1 06B 015 BT15	TF2 06B 015 BT15		3/8"x7/32"	15	15	55	55		9	49,3	5,3	10	45,81	0,13	0,23	
TF1 06B 015 BT18	TF2 06B 015 BT18	TF3 06B 015 BT18	3/8"x7/32"	18	15	55	60	70	9	49,3	5,3	10	45,81	0,13	0,23	0,26
TF1 08B 015 BT18	TF2 08B 015 BT18		1/2"x5/16"	18	15	55	60		9	65,5	7,2	10	61,09	0,21	0,37	
		TF3 08B 015 BT27	1/2"x5/16"	27	15			90	12	65,5	7,2	12	61,09			0,51
TF1 10B 015 BT27	TF2 10B 015 BT27	TF3 10B 015 BT27	5/8"x3/8"	27	15	80	90	90	12	83,0	9,1	12	76,36	0,38	0,60	0,96
		TF3 10B 015 BT38	5/8"x3/8"	38	15			120	15	83,0	9,1	20	76,36			1,26
TF1 12B 015 BT27	TF2 12B 015 BT27		3/4"x7/16"	27	15	80	90	90	12	99,8	11,1	12	91,63	0,56	1,00	
TF1 12B 015 BT38	TF2 12B 015 BT38	TF3 12B 015 BT38	3/4"x7/16"	38	15	80	90	120	15	99,8	11,1	20	91,63	0,81	1,35	1,60
TF1 16B 013 BT38	TF2 16B 013 BT38		1"x17,02 mm	38	13	100	120	120	15	117,0	16,2	20	106,12	1,23	2,10	
		TF3 16B 013 BT45	1"x17,02 mm	45	13			160	15	117,0	16,2	20	106,12			2,92
TF1 20B 013 BT45	TF2 20B 013 BT45	TF3 20B 013 BT45	1" 1/4x3/4"	45	13	100	140	160	15	147,8	18,5	20	132,65	2,28	3,60	5,20
TF1 24B 011 BT45	TF2 24B 011 BT45	TF3 24B 011 BT45	1" 1/2x1"	45	11	140	140	180	15	150,0	24,1	20	135,21	2,33	4,20	6,10

Z: Anzahl der Zähne



PET-KETTENGLEITER: ZUBEHÖR TYP OVR



Elliptische OVR-Kettengleiter aus Polyethylen mit hoher molekularer Dichte, ausgelegt für eine einfache Spannung auf einer Einfach-, Zweifach- oder Dreifachkette mit einer Betriebsgeschwindigkeit von $<0,35\text{m/s}$ und einer Temperatur von $<80^\circ\text{C}$.

Diese Art von Kettengleiter ist besonders geeignet für kleine Achsabstände und den Einbau nahe zum Kettenrad. Ihre Form ermöglicht insbesondere die Verwendung von zwei Seiten und bietet eine um das 2-fache längere Lebensdauer als herkömmliche Kettengleiter.

Die Sets werden komplett mit Schrauben und Muttern aus verzinktem Stahl geliefert (Set ist auch mit Schrauben und Muttern aus Edelstahl erhältlich).

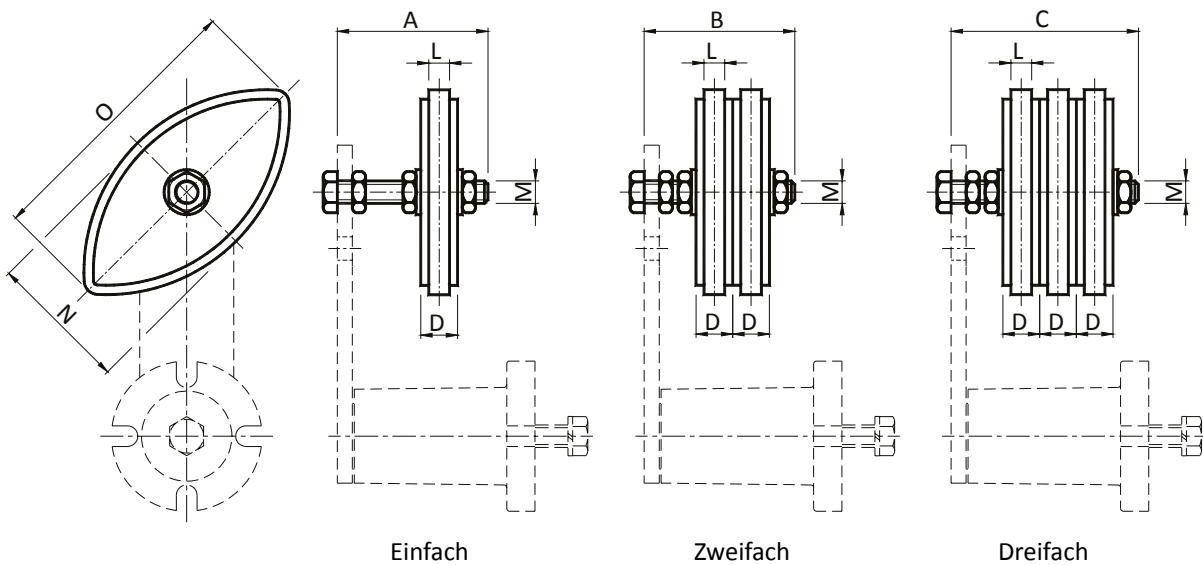

Für Zweifachketten werden zwei Kettengleiter nebeneinander verwendet.
Für Dreifachketten werden drei Kettengleiter nebeneinander verwendet.

Art. Nr. Einfachkette (S)	Art. Nr. Zweifachkette (D)	Art. Nr. Dreifachkette (T)	Ketten	Größe											Kg	
					A	B	C	D	L	M	N	O	S	D	T	
OVR 06B1 BT 11	OVR 06B2 BT11		3/8" x 7/32"	11	45	45		10,2	5	M 8	40	75	0,09	0,10		
		OVR 06B3 BT15	3/8" x 7/32"	15			55	10,2	5	M10	40	75				0,11
OVR 08B1 BT15	OVR 08B2 BT15		1/2" x 5/16"	15	55	55		13,9	7	M10	50	96	0,10	0,11		
OVR 08B1 BT18	OVR 08B2 BT18	OVR 08B3 BT18	1/2" x 5/16"	18	55	60	75	13,9	7	M10	50	96	0,11	0,12	0,13	
OVR 10B1 BT18	OVR 10B2 BT18		5/8" x 3/8"	18	55	70		16,6	9	M10	65	126	0,12	0,14		
		OVR 10B3 BT27	5/8" x 3/8"	27			90	16,6	9	M12	65	126				0,16
OVR 12B1 BT18	OVR 12B2 BT18		3/4" x 7/16"	18	60	70		19,5	11	M10	74	148	0,13	0,15		
OVR 12B1 BT27	OVR 12B2 BT27	OVR 12B3 BT27	3/4" x 7/16"	27	80	80	100	19,5	11	M12	74	148	0,20	0,22	0,25	



SPANNROLLEN: ZUBEHÖR RLP - RLA

**ROLLE AUS
POLYAMID - TYP RLP**



Auf selbst schmierenden Lagern montierte Rolle. Ideal für die Regelung der Riemen­spannung.

Die Betriebstemperatur sollte für Polyamid Spannrollen bei $\leq 70^{\circ}\text{C}$ und bei Spannrollen aus verzinktem Stahl bei $\leq 100^{\circ}\text{C}$ liegen.

Die Sets werden mit verzinkten Schrauben geliefert.

ROLLE AUS VERZINKTEM STAHL - TYP RLA

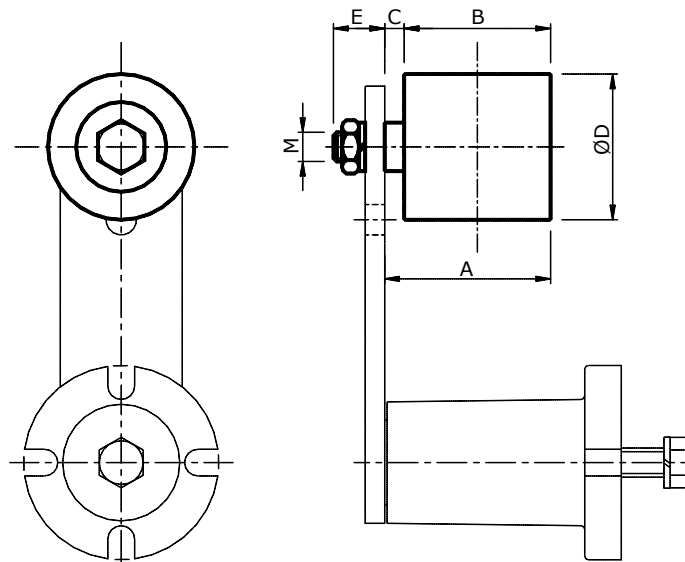

Rolle aus Polyamid			Rolle aus verzinktem Stahl								Max. Geschwindigkeit	Größe
Art. Nr.	M	Kg	Art. Nr.	M	Kg	A	B	C	$\varnothing D$	E	[UpM]	
RLP 30	M8	0.08	RLA 30	M8	0.16	38	35	3	30	13	8000	11
RLP 40	M10	0.18	RLA 40	M10	0.37	51	45	6	40	16	8000	15-18
RLP 60	M12	0.40	RLA 60	M16	0.85	68	60	8	60	21	6000	27
RLP 80	M20	1.20	RLA 80	M20	2.09	99	90	9	80	28	5000	38
RLP 90	M20	1.70	RLA 90	M20	2.44	142	135	7	90	27	4500	45



KEILRIEMENSCHLEIBEN: ZUBEHÖR TYP KSP



Keilriemenscheibe aus Guss mit selbstschmierender Lagerung.

Auf Wunsch sind Rollen mit einem anderen Profil oder gezahnte Rollen lieferbar.

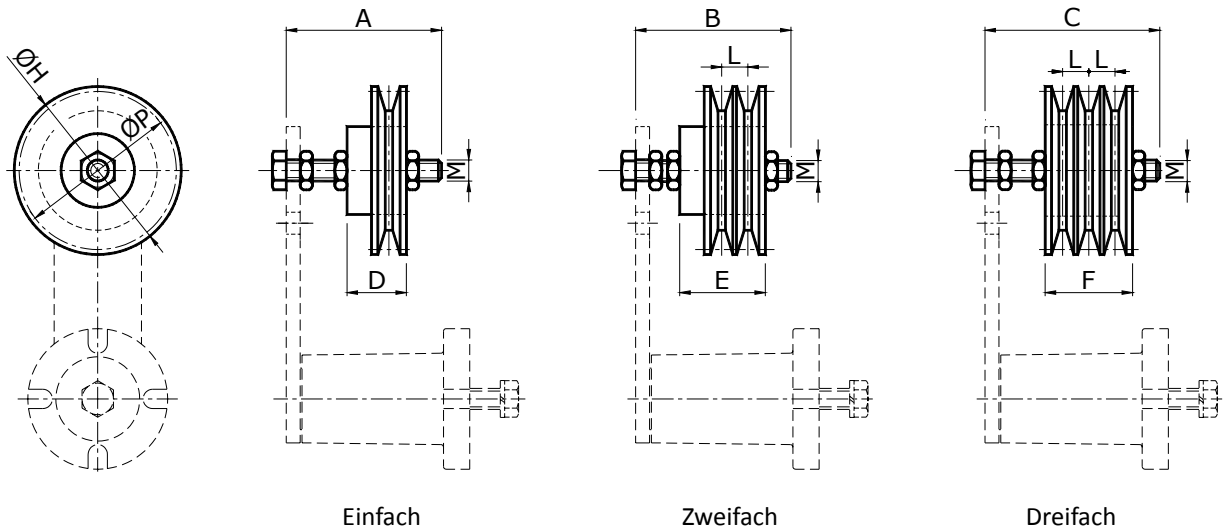

Art. Nr. Riemen einfach (S)	Art. Nr. Riemen zweifach (D)	Art. Nr. Riemen dreifach (T)	Riemen	Größe											Kg		
					A	B	C	D	E	F	ØH	L	ØP	M	S	D	T
KSPZ 063/1	KSPZ 063/2	KSPZ 063/3	SPZ	18	55	60	70	24	35	40	67	12	63	M10	0,40	0,70	1,10
KSPA 090/1	KSPA 090/2	KSPA 090/3	SPA	27	80	80	80	34	49	50	95,6	15	90	M12	1,00	1,70	1,80
KSPB 125/1	KSPB 125/2		SPB	27	80	90		41	60		132	19	125	M12	1,90	2,80	
		KSPB 125/3	SPB	38			120			63	132	19	125	M20			3,50



AXIALE SPANNVORRICHTUNGEN TAS



Typ TASZ mit Feder aus verzinktem Stahl
Typ TASX mit Feder aus Edelstahl

Material: Die TAS Spannvorrichtungen werden aus Kunststoff hergestellt, mit Schrauben aus rostfreiem Stahl.
 Die Feder im Inneren kann aus verzinktem Stahl oder rostfreiem Stahl gefertigt sein.

Verwendung: Maximale Arbeitstemperatur 80°C
 Alle Gehäuse werden mit einem Vorspannsystem geliefert.
 Maximaler Verfahrweg 40 mm.

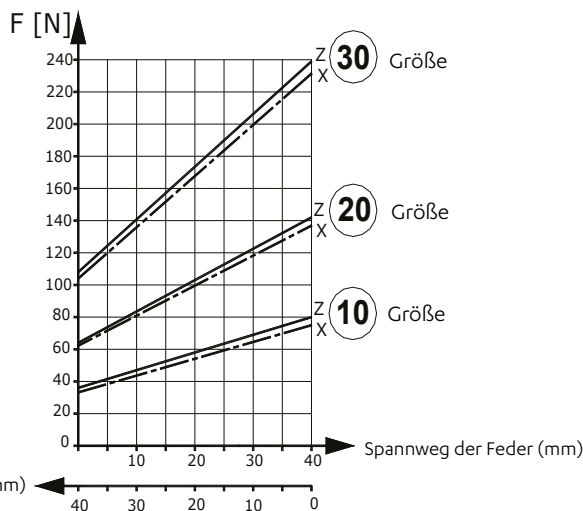
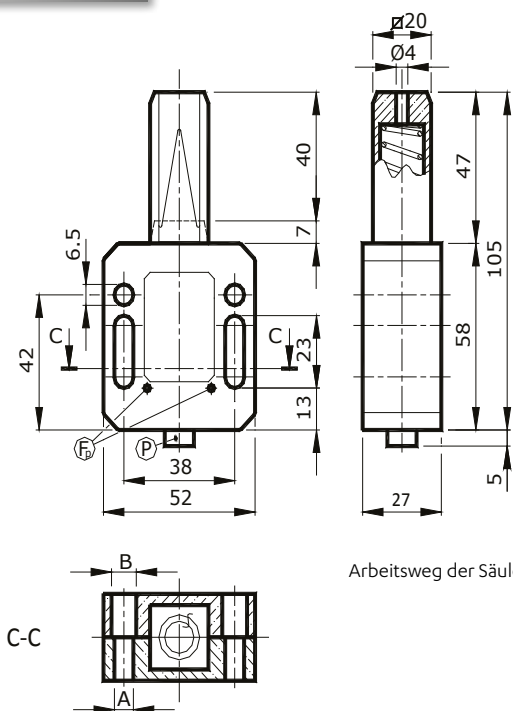

Arbeitsweg der Säule (mm)

Belastungsdiagramm

F_p = Vorbelastungsbohrung
 P = Vorbelastungsspitze

A	B	Mit Feder aus verzinktem Stahl		Mit Feder aus rostfreiem Stahl	
		Art. Nr.	Kraft (N)*	Art. Nr.	Kraft (N)*
6,5	6,5	TAS 10-6Z	36-79	TAS 10-6X	35-77
8,5	8,5	TAS 10-8Z	36-79	TAS 10-8X	35-77
6,5	8,5	TAS 10-6/8Z	36-79	TAS 10-6/8X	35-77
6,5	6,5	TAS 20-6Z	64-142	TAS 20-6X	63-139
8,5	8,5	TAS 20-8Z	64-142	TAS 20-8X	63-139
6,5	8,5	TAS 20-6/8Z	64-142	TAS 20-6/8X	63-139
6,5	6,5	TAS 30-6Z	108-239	TAS 30-6X	105-233
8,5	8,5	TAS 30-8Z	108-239	TAS 30-8X	105-233
6,5	8,5	TAS 30-6/8Z	108-239	TAS 30-6/8X	105-233

* Die erste Ziffer zeigt den Federdruck am Ende des Weges an, die zweite Zahl bei totaler Kompression.

BEI JEDEM AUFTRAG IST ANZUGEBEN:

- Art der axialen Spannvorrichtung : TAS - TAD - TBD - TCD
- Art der Kettengleiter : PF - PG - PC - PV - QG - QV
- Art der Kette : Ihre Bezugs-ISO und das Maß in mm
- Art der Feder : Nur anzugeben, wenn rostfrei erwünscht ist (standardmäßig: verzinkt)



SET FÜR AXIALE SPANNVORRICHTUNGEN - PET-KETTENGLEITER - TYP PF

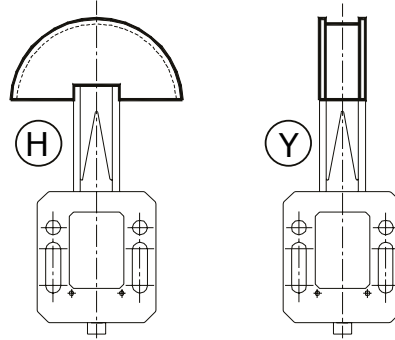

Positionierung der Kettengleiter

Material: Das Set besteht aus einem Polyethylenkettengleiter mit hoher molekularer Dichte mit Schrauben aus rostfreiem Stahl.

Verwendung: Verfahrensgeschwindigkeit $\leq 20\text{m/min}$
Verfahrtemperatur der Kettengleiter $\leq 70^\circ\text{C}$

Empfehlenswert für kurze Achsenabstände.
Die Ausrichtung (H oder Y) ist anzugeben. Standardmäßig erfolgt die Montage in Position H.

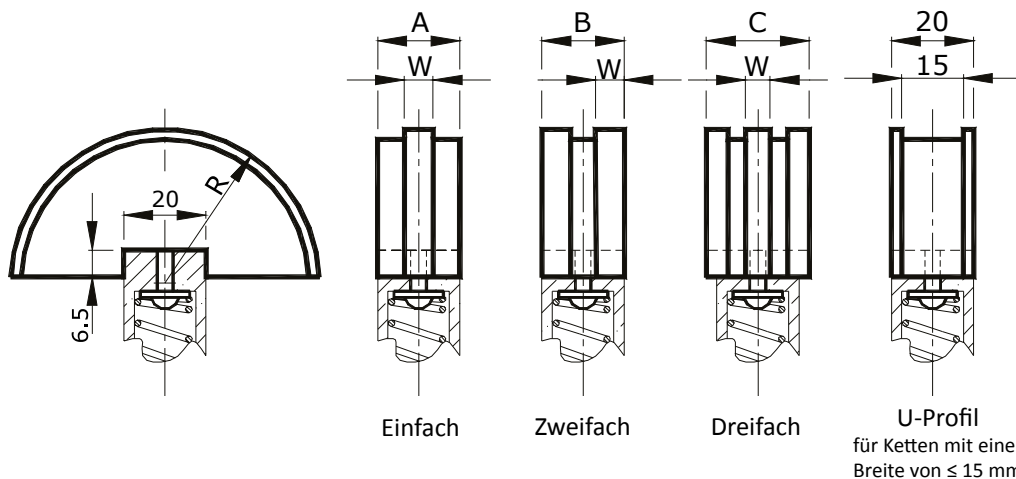

Art. Nr. - Kettengleiter				Größe							Kg			
Art. Nr. Einfach	Art. Nr. Doppel (D)	Art. Nr. Dreifach	Art. Nr. - U-Profil	Kette		R	A	B	C	W	Einfach	Zweifach	Dreifach	U-Profil
PF AS			PF AU	6 mm	10	37,5	20			2,3	0,03			0,03
PF OS	PF OD		PF AU	8 mm	10	37,5	20	20		2,5	0,03	0,03		0,03
		PF OT		8 mm	20	37,5			20	2,5				0,04
		PF OT		8 mm	30	37,5			20	2,5				0,04
PF 1S	PF 1D		PF AU	3/8"x7/32"	10	37,5	20	20		5	0,03	0,03		0,03
PF 1S	PF 1D	PF 1T	PF AU	3/8"x7/32"	20	37,5	20	20	25	5	0,03	0,03	0,04	0,03
		PF 1T		3/8"x7/32"	30	37,5			25	5				0,04
PF 2S	PF 2D			1/2"x5/16"	20	37,5	20	20		7	0,03	0,04		
PF 2S	PF 2D			1/2"x5/16"	30	37,5	20	20		7	0,03	0,04		
PF 3S				5/8"x3/8"	20	40	20			9	0,04			
PF 3S	PF 3D			5/8"x3/8"	30	40	20	25		9	0,04	0,08		
PF 4S				3/4"x7/16"	30	40	20			11	0,05			

Diese Produktreihe wird als Set angeboten: Axiale Spannvorrichtungen auf der einen Seite / Kettengleiter auf der anderen



AXIALE SPANNVORRICHTUNGEN TAD



Typ TADZ mit Feder aus verzinktem Stahl
Typ TADX mit Feder aus rostfreiem Stahl

Material: Die TAD Spannvorrichtungen werden aus Kunststoff hergestellt, mit Schrauben aus rostfreiem Stahl.
 Die Federn können verzinkt (TADZ) oder rostfrei (TADX) geliefert werden.

Verwendung: Elastischer Kettenspanner.
 Alle Gehäuse werden mit einem Vorspannsystem geliefert.
 Maximale Arbeitstemperatur 80°C
 Maximaler Verfahrensweg 40 mm

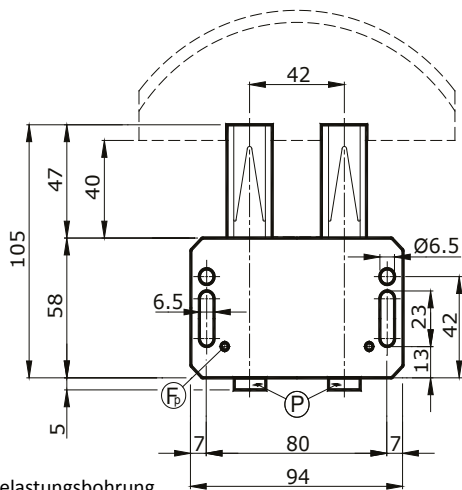

Fp = Vorbelastungsbohrung
 P = Vorbelastungsspitze

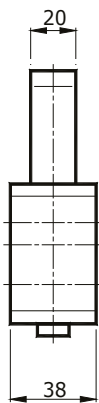

Arbeitsweg der Säule (mm)

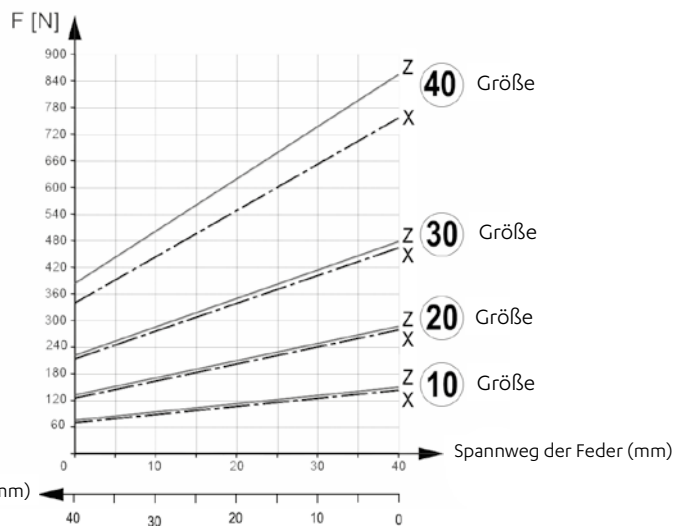

Belastungsdiagramm

Mit Federn aus verzinktem Stahl		Mit Feder aus rostfreiem Stahl		Kg
Art. Nr.	Kraft (N)*	Art. Nr.	Kraft (N)*	
TAD 10Z	72 - 158	TAD 10X	70 - 154	0,24
TAD 20Z	128 - 284	TAD 20X	126 - 278	0,24
TAD 30Z	216 - 478	TAD 30X	210 - 466	0,24
TAD 40Z	388 - 859	TAD 40X	343 - 759	0,24

* Die erste Ziffer zeigt den Federdruck am Ende des Weges an, die zweite Zahl bei totaler Kompression.

BEI JEDEM AUFTRAG IST ANZUGEBEN:

- Art der axialen Spannvorrichtung : TAS - TAD - TBD - TCD
- Art der Kettengleiter : PF - PG - PC - PV - QG - QV
- Art der Kette : Ihre Bezugs-ISO und das Maß in mm
- Art der Feder : Nur anzugeben, wenn rostfrei erwünscht ist (standardmäßig: verzinkt)



SET FÜR AXIALE SPANNVORRICHTUNGEN - PET-KETTENGLEITER - TYP PG



Material: PET-Kettengleiter mit hoher molekularer Dichte
Schrauben aus Edelstahl

Verwendung: Tiefer gelegtes, halbrundes Profil, konstruiert für einen langen Achsabstand.
Betriebsgeschwindigkeit $\leq 20\text{m/min}$
Betriebstemperatur $\leq 70\text{m/min}$

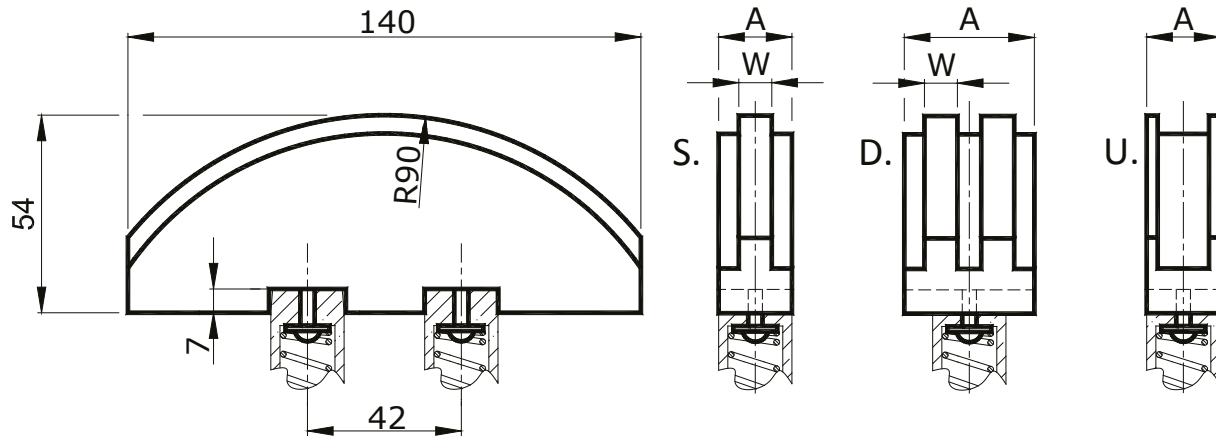

Typ	Kette	A	W	Kg
PG 1 U	$\leq 06\text{-B1}$	20		0,11
PG 2 S	08-B1	20	7	0,11
PG 3 S	10-B1	20	9	0,11
PG 4 S	12-B1	20	11	0,11
PG 5 S	16-B1	20	16	0,14
PG 0 D	05-B2	20	2,5	0,11
PG 1 D	06-B2	20	5	0,11
PG 2 D	08-B2	20	7	0,11
PG 3 D	10-B2	25	9	0,14
PG 4 D	12-B2	30	11	0,16



KOMPLETTE AXIALE SPANNVORRICHTUNGEN TAD + KETTENGLEITER PG

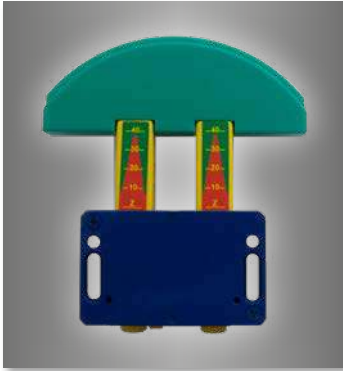

Typ TADZ mit Feder aus verzinktem Stahl
 Typ TADX mit Feder aus rostfreiem Stahl

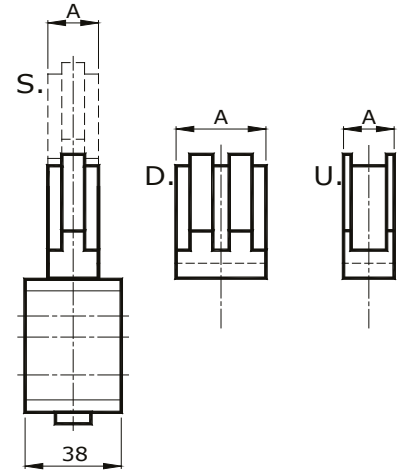
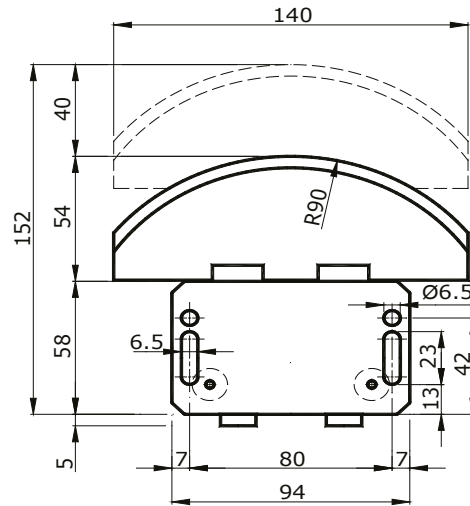

Kette DIN 8187 ISO	Mit Federn aus verzinktem Stahl			Mit Feder aus rostfreiem Stahl			
	TADZ+PG	TADZ	PG	TADX	TADX+PG		
≤06-B1	≤3/8"x7/32"	TAD10ZPG1U	TAD 10 Z	PG U	20	TAD 10 X	TAD10XPG1U
08-B1	1/2"x5/16"	TAD10ZPG2S	TAD 10 Z	PG 2 S	20	TAD 10 X	TAD10XPG2S
08-B1	1/2"x5/16"	TAD20ZPG2S	TAD 20 Z	PG 2 S	20	TAD 20 X	TAD20XPG2S
10-B1	5/8"x3/8"	TAD10ZPG3S	TAD 10 Z	PG 3 S	20	TAD 10 X	TAD10XPG3S
10-B1	5/8"x3/8"	TAD20ZPG3S	TAD 20 Z	PG 3 S	20	TAD 20 X	TAD20XPG3S
10-B1	5/8"x3/8"	TAD30ZPG3S	TAD 30 Z	PG 3 S	20	TAD 30 X	TAD30XPG3S
12-B1	3/4"x7/16"	TAD10ZPG4S	TAD 10 Z	PG 4 S	20	TAD 10 X	TAD10XPG4S
12-B1	3/4"x7/16"	TAD20ZPG4S	TAD 20 Z	PG 4 S	20	TAD 20 X	TAD20XPG4S
12-B1	3/4"x7/16"	TAD30ZPG4S	TAD 30 Z	PG 4 S	20	TAD 30 X	TAD30XPG4S
16-B1	1"x17,02mm	TAD30ZPG5S	TAD 30 Z	PG 5 S	20	TAD 30 X	TAD30XPG5S
16-B1	1"x17,02mm	TAD40ZPG5S	TAD 40 Z	PG 5 S	20	TAD 40 X	TAD40XPG5S
05-B2	8mm	TAD10ZPG0D	TAD 10 Z	PG 0 D	20	TAD 10 X	TAD10XPG0D
06-B2	3/8"x7/32"	TAD10ZPG1D	TAD 10 Z	PG 1 D	20	TAD 10 X	TAD10XPG1D
06-B2	3/8"x7/32"	TAD20ZPG1D	TAD 20 Z	PG 1 D	20	TAD 20 X	TAD20XPG1D
08-B2	1/2"x5/16"	TAD20ZPG2D	TAD 20 Z	PG 2 D	20	TAD 20 X	TAD20XPG2D
10-B2	5/8"x3/8"	TAD20ZPG3D	TAD 20 Z	PG 3 D	25	TAD 20 X	TAD20XPG3D
10-B2	5/8"x3/8"	TAD30ZPG3D	TAD 30 Z	PG 3 D	25	TAD 30 X	TAD30XPG3D
12-B2	3/4"x7/16"	TAD20ZPG4D	TAD 20 Z	PG 4 D	30	TAD 20 X	TAD20XPG4D
12-B2	3/4"x7/16"	TAD30ZPG4D	TAD 30 Z	PG 4 D	30	TAG 30 X	TAD30XPG4D

Spannvorrichtungen für Dreifachketten nur auf Anfrage.



AXIALE SPANNVORRICHTUNGEN TBD

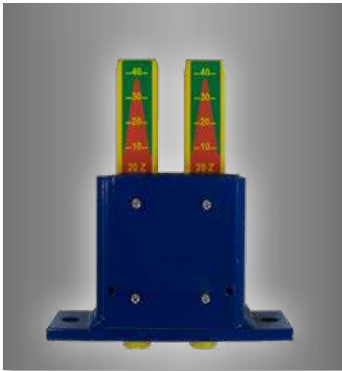

Typ TBDZ mit Federn aus verzinktem Stahl Typ TBDX mit Federn aus rostfreiem Stahl

Material: Äußeres Gehäuse aus lackiertem Stahl. Innere Bestandteile aus Kunststoff. Rostfreie Bolzen. Die inneren Federn können verzinkt (TBDZ) oder rostfrei (TBDX) geliefert werden.

Verwendung: Elastischer Kettenspanner.
Alle Gehäuse werden mit einem Vorspannsystem geliefert.
Maximale Arbeitstemperatur 80°C.
Maximaler Verfahrweg 40 mm.

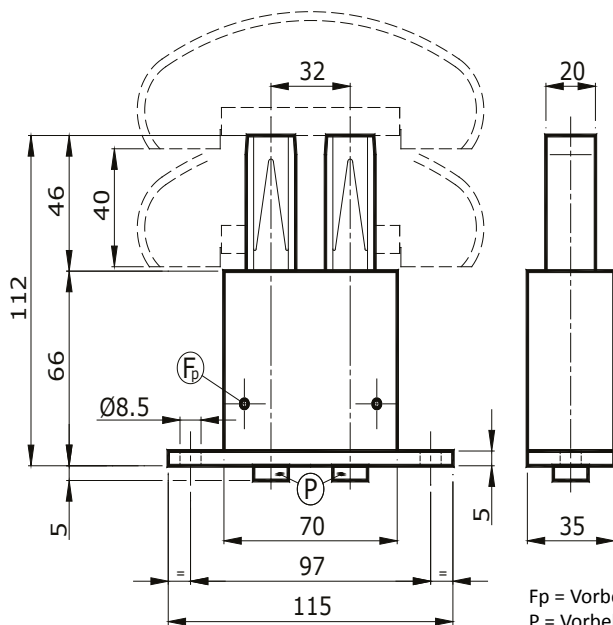

Fp = Vorbelastungsbohrung
P = Vorbelastungsspitze

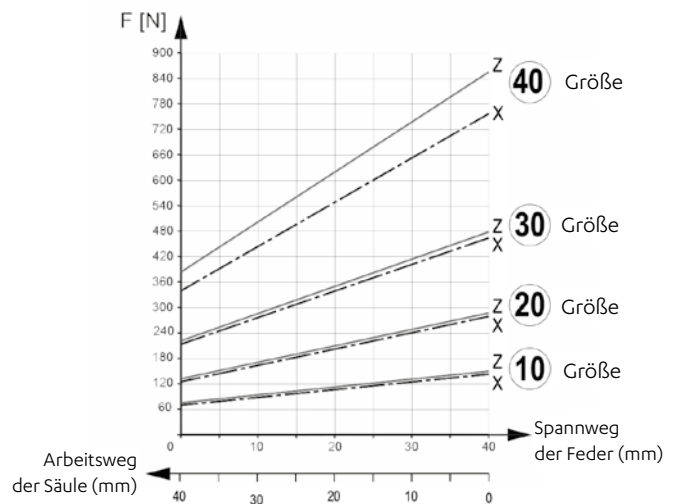

Belastungsdiagramm

Mit Federn aus verzinktem Stahl		Mit Feder aus rostfreiem Stahl		Kg
Art. Nr.	Kraft (N)*	Art. Nr.	Kraft (N)*	
TBD 10Z	72 - 158	TBD 10X	70 - 154	0,60
TBD 20Z	128 - 284	TBD 20X	126 - 278	0,60
TBD 30Z	216 - 478	TBD 30X	210 - 466	0,60
TBD 40Z	388 - 859	TBD 40X	343 - 759	0,60

* Die erste Ziffer zeigt den Federdruck am Ende des Weges an, die zweite Zahl bei totaler Kompression.

BEI JEDEM AUFTRAG IST ANZUGEBEN:

- Art der axialen Spannvorrichtung : TAS - TAD - TBD - TCD
- Art der Kettengleiter : PF - PG - PC - PV - QG - QV
- Art der Kette : Ihre Bezugs-ISO und das Maß in mm
- Art der Feder : Nur anzugeben, wenn rostfrei erwünscht ist (standardmäßig: verzinkt)



SET FÜR AXIALE SPANNVORRICHTUNGEN - PET-KETTENGLEITER - TYP PC

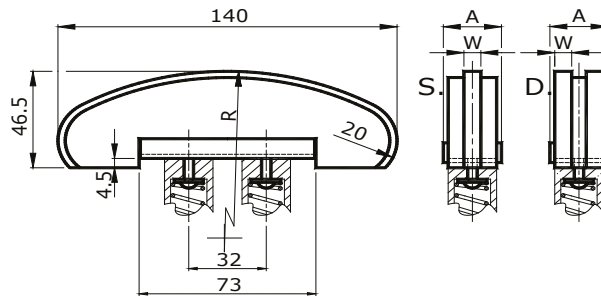

Material: PET-Kettengleiter mit hoher molekularer Dichte.
Rostfreie Bolzen.
Stahlprofil.

Verwendung: Tiefer gelegtes, kreisrundes Profil konstruiert für mittleren bis langen Achsabstand.
Betriebsgeschwindigkeit $\leq 20\text{m/min}$.
Maximale Betriebstemperatur $\leq 70^\circ\text{C}$.

Art. Nr.	Kette	A	R	W	Kg
PC 0 S	05-B1	24	120	2,5	0,13
PC 1 S	06-B1	24	120	5	0,14
PC 2 S	08-B1	24	120	7	0,14
PC 3 S	10-B1	24	140	9	0,11
PC 4 S	12-B1	24	140	11	0,16
PC 5 S	16-B1	29	160	16	0,18
PC 6 S	20-B1	29	160	18	0,28
PC 0 D	05-B2	24	120	2,5	0,13
PC 1 D	06-B2	24	120	5	0,14
PC 2 D	08-B2	24	120	7	0,18
PC 3 D	10-B2	29	140	9	0,18
PC 4 D	12-B2	34	140	11	0,33
PC 5 D	16-B2	52	160	16	0,56

SET FÜR AXIALE SPANNVORRICHTUNGEN - PET-KETTENGLEITER - TYP PV

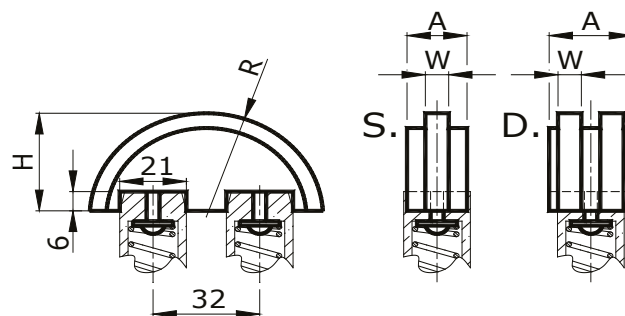

Material: PET-Kettengleiter mit hoher molekularer Dichte.
Rostfreie Bolzen.

Verwendung: Tiefer gelegtes, halbrundes Profil, konstruiert für einen kurzen Achsabstand.
Betriebsgeschwindigkeit $\leq 20\text{m/min}$.
Maximale Betriebstemperatur $\leq 70\text{m/min}$.

Art. Nr.	Kette	A	R	H	W	Kg
PV 1 S	06-B1	18	35	33	5	0,03
PV 2 S	08-B1	18	35	33	7	0,03
PV 3 S	10-B1	18	45	43	9	0,05
PV 4 S	12-B1	18	45	43	11	0,08
PV 1 D	06-B2	18	35	33	5	0,03
PV 2 D	08-B2	21	35	33	7	0,03
PV 3 D	10-B2	25	45	43	9	0,08
PV 4 D	12-B2	30	45	43	11	0,09



KOMPLETTE AXIALE SPANNVORRICHTUNGEN TBD + KETTENGLEITER PC

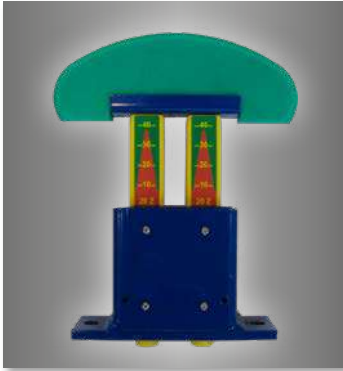

Typ TBDZ mit Federn aus verzinktem Stahl
 Typ TBDX mit Federn aus rostfreiem Stahl

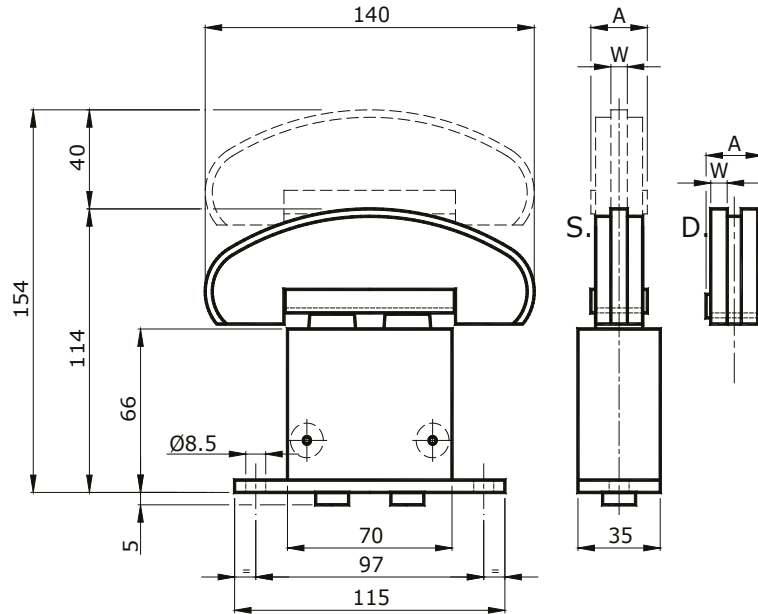

Kette DIN 8187 ISO	Mit Federn aus verzinktem Stahl			Mit Feder aus rostfreiem Stahl			
	TBDZ + PC	TBDZ	PC	A	W	TBDX	TBDX+PC
05-B1 8mm	TBD10ZPC0S	TBD 10 Z	PC 0 S	24	2,5	TBD 10 X	TBD10XPC0S
06-B1 3/8"x7/32"	TBD10ZPC1S	TBD 10 Z	PC 1 S	24	5	TBD 10 X	TBD10XPC1S
06-B1 3/8"x7/32"	TBD20ZPC1S	TBD 20 Z	PC 1 S	24	5	TBD 20 X	TBD20XPC1S
08-B1 1/2"x5/16"	TBD10ZPC2S	TBD 10 Z	PC 2 S	24	7	TBD 10 X	TBD10XPC2S
08-B1 1/2"x5/16"	TBD20ZPC2S	TBD 20 Z	PC 2 S	24	7	TBD 20 X	TBD20XPC2S
10-B1 5/8"x3/8"	TBD20ZPC3S	TBD 20 Z	PC 3 S	24	9	TBD 20 X	TBD20XPC3S
10-B1 5/8"x3/8"	TBD30ZPC3S	TBD 30 Z	PC 3 S	24	9	TBD 30 X	TBD30XPC3S
12-B1 3/4"x7/16"	TBD20ZPC4S	TBD 20 Z	PC 4 S	24	11	TBD 20 X	TBD20XPC4S
12-B1 3/4"x7/16"	TBD30ZPC4S	TBD 30 Z	PC 4 S	24	11	TBD 30 X	TBD30XPC4S
16-B1 1"x17,02mm	TBD30ZPC5S	TBD 30 Z	PC 5 S	29	16	TBD 30 X	TBD30XPC5S
16-B1 1"x17,02mm	TBD40ZPC5S	TBD 40 Z	PC 5 S	29	16	TBD 40 X	TBD40XPC5S
20-B1 1 1/4"x3/4"	TBD30ZPC6S	TBD 30 Z	PC 6 S	29	18	TBD 30 X	TBD30XPC6S
20-B1 1 1/4"x3/4"	TBD40ZPC6S	TBD 40 Z	PC 6 S	29	18	TBD 40 X	TBD40XPC6S
05-B2 8mm	TBD10ZPC0D	TBD 10 Z	PC 0 D	24	2,5	TBD 10 X	TBD10XPC0D
06-B2 3/8"x7/32"	TBD10ZPC1D	TBD 10 Z	PC 1 D	24	5	TBD 10 X	TBD10XPC1D
06-B2 3/8"x7/32"	TBD20ZPC1D	TBD 20 Z	PC 1 D	24	5	TBD 20 X	TBD20XPC1D
08-B2 1/2"x5/16"	TBD20ZPC2D	TBD 20 Z	PC 2 D	24	7	TBD 20 X	TBD20XPC2D
10-B2 5/8"x3/8"	TBD20ZPC3D	TBD 20 Z	PC 3 D	29	9	TBD 20 X	TBD20XPC3D
10-B2 5/8"x3/8"	TBD30ZPC3D	TBD 30 Z	PC 3 D	29	9	TBD 30 X	TBD30XPC3D
12-B2 3/4"x7/16"	TBD30ZPC4D	TBD 30 Z	PC 4 D	34	11	TBD 30 X	TBD30XPC4D
16-B2 1"x17,02mm	TBD30ZPC5D	TBD 30 Z	PC 5 D	52	16	TBD 30 X	TBD30XPC5D
16-B2 1"x17,02mm	TBD40ZPC5D	TBD 40 Z	PC 5 D	52	16	TBD 40 X	TBD40XPC5D

Spannvorrichtungen für Dreifachketten nur auf Anfrage.



KOMPLETTE AXIALE SPANNVORRICHTUNGEN TBD + KETTENGLEITER PV

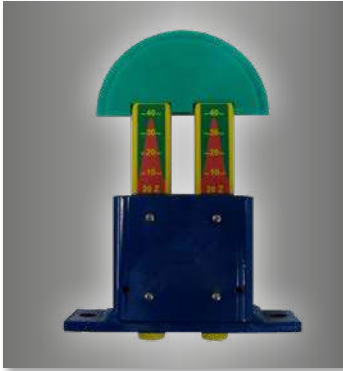

Typ TBDZ mit Federn aus verzinktem Stahl
 Typ TBX mit Federn aus rostfreiem Stahl

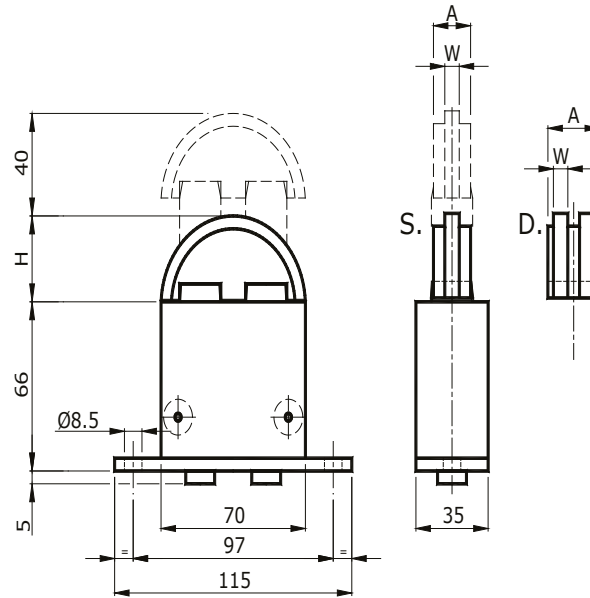

Kette DIN 8187 ISO	Mit Federn aus verzinktem Stahl			Mit Feder aus rostfreiem Stahl				
	TBDZ + PV	TBDZ	PV	A	H	W	TBDX + PV	TBDX
06-B1 3/8"x7/32"	TBD10ZPV1S	TBD 10 Z	PV 1 S	18	33	5	TBD 10 X	TBD10XPV1S
06-B1 3/8"x7/32"	TBD20ZPV1S	TBD 20 Z	PV 1 S	18	33	5	TBD 20 X	TBD20XPV1S
08-B1 1/2"x5/16"	TBD10ZPV2S	TBD 10 Z	PV 2 S	18	33	7	TBD 10 X	TBD10XPV2S
08-B1 1/2"x5/16"	TBD20ZPV2S	TBD 20 Z	PV 2 S	18	33	7	TBD 20 X	TBD20XPV2S
10-B1 5/8"x3/8"	TBD20ZPV3S	TBD 20 Z	PV 3 S	18	43	9	TBD 20 X	TBD20XPV3S
10-B1 5/8"x3/8"	TBD30ZPV3S	TBD 30 Z	PV 3 S	18	43	9	TBD 30 X	TBD30XPV3S
12-B1 3/4"x7/16"	TBD20ZPV4S	TBD 20 Z	PV 4 S	18	43	11	TBD 20 X	TBD20XPV4S
12-B1 3/4"x7/16"	TBD30ZPV4S	TBD 30 Z	PV 4 S	18	43	11	TBD 30 X	TBD30XPV4S
06-B2 3/8"x7/32"	TBD10ZPV1D	TBD 10 Z	PV 1 D	18	43	5	TBD 10 X	TBD10XPV1D
06-B2 3/8"x7/32"	TBD20ZPV1D	TBD 20 Z	PV 1 D	18	33	5	TBD 20 X	TBD20XPV1D
08-B2 1/2"x5/16"	TBD20ZPV2D	TBD 20 Z	PV 2 D	21	43	7	TBD 20 X	TBD20XPV2D
10-B2 5/8"x3/8"	TBD20ZPV3D	TBD 20 Z	PV 3 D	25	43	9	TBD 20 X	TBD20XPV3D
10-B2 5/8"x3/8"	TBD30ZPV3D	TBD 30 Z	PV 3 D	25	43	9	TBD 30 X	TBD30XPV3D
12-B2 3/4"x7/16"	TBD30ZPV4D	TBD 30 Z	PV 4 D	30	43	11	TBD 30 X	TBD30XPV4D

Spannvorrichtungen für Dreifachketten nur auf Anfrage.



AXIALE SPANNVORRICHTUNGEN TCD



Typ TCDZ mit Federn aus verzinktem Stahl Typ TCDX mit Federn aus rostfreiem Stahl

Material: Äußeres Gehäuse aus lackiertem Stahl. Innere Bestandteile aus Kunststoff. Rostfreie Bolzen. Die inneren Federn können verzinkt (TCDZ) oder rostfrei (TCDX) geliefert werden.

Verwendung: Elastischer Kettenspanner.
Alle Gehäuse werden mit einem Vorspannsystem geliefert.
Maximale Arbeitstemperatur 80°C.
Maximaler Verfahrweg 40 mm.

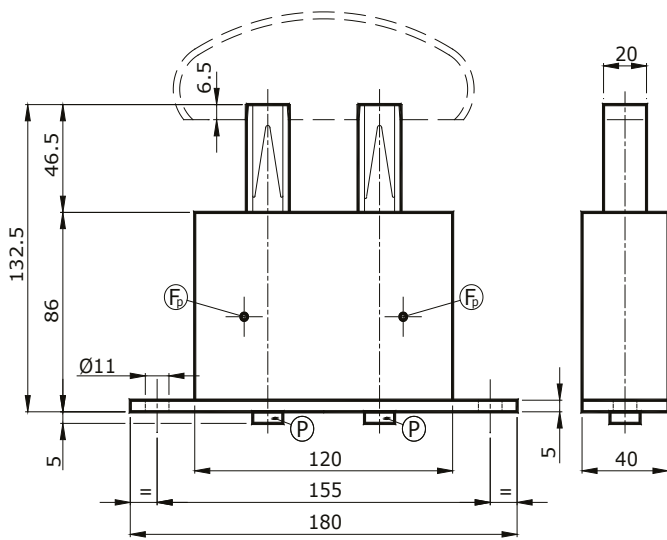

Fp = Vorbelastungsbohrung
P = Vorbelastungsspitze

Arbeitsweg der Säule (mm)

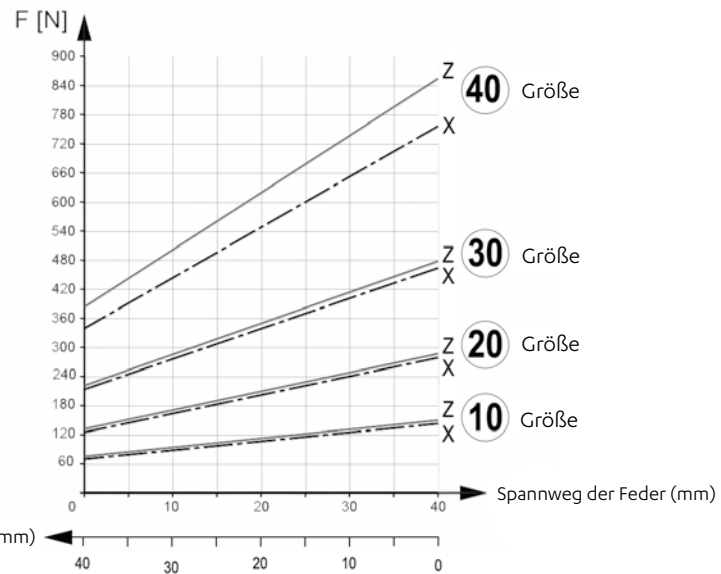

Belastungsdiagramm

Mit Federn aus verzinktem Stahl		Mit Feder aus rostfreiem Stahl		Kg
Art. Nr.	Kraft (N)*	Art. Nr.	Kraft (N)*	
TCD 10Z	72 - 158	TCD 10X	70 - 154	1,25
TCD 20Z	128 - 284	TCD 20X	126 - 278	1,25
TCD 30Z	216 - 478	TCD 30X	210 - 466	1,25
TCD 40Z	388 - 859	TCD 40X	343 - 759	1,25

* Die erste Ziffer zeigt den Federdruck am Ende des Weges an, die zweite Zahl bei totaler Kompression.

BEI JEDEM AUFTRAG IST ANZUGEBEN:

- Art der axialen Spannvorrichtung : TAS - TAD - TBD - TCD
- Art der Kettengleiter : PF - PG - PC - PV - QG - QV
- Art der Kette : Ihre Bezugs-ISO und das Maß in mm
- Art der Feder : Nur anzugeben, wenn rostfrei erwünscht ist (standardmäßig: verzinkt)



SET FÜR AXIALE SPANNVORRICHTUNGEN - PET-KETTENGLEITER - TYP QG

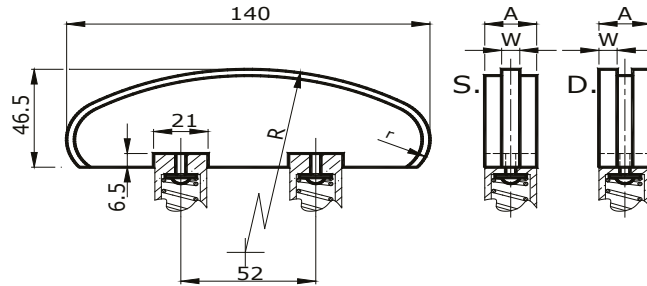

Material: PET-Kettengleiter mit hoher molekularer Dichte.
Rostfreie Bolzen.

Verwendung: Tiefer gelegtes, kreisrundes Profil konstruiert für mittleren bis langen Achsabstand.
Betriebsgeschwindigkeit $\leq 20\text{m/min}$.
Betriebstemperatur $\leq 70\text{ }^\circ\text{C}$.

Art. Nr.	Kette	A	R	W	Kg
QG 0 S	05-B1	20	120	2,5	0,07
QG 1 S	06-B1	20	120	5	0,07
QG 2 S	08-B1	20	120	7	0,08
QG 3 S	10-B1	20	140	9	0,10
QG 4 S	12-B1	20	140	11	0,12
QG 5 S	16-B1	25	160	16	0,20
QG 6 S	20-B1	25	160	18	0,20
QG 7 S	24-B1	30	160	24	0,35
QG 0 D	05-B2	20	120	2,5	0,07
QG 1 D	06-B2	20	120	5	0,08
QG 2 D	08-B2	20	120	7	0,08
QG 3 D	10-B2	25	140	9	0,12
QG 4 D	12-B2	30	140	11	0,25
QG 5 D	16-B2	48	160	16	0,50
QG 6 D	20-B2	55	160	18	1,30
QG 7 D	24-B2	70	160	24	1,40

SET FÜR AXIALE SPANNVORRICHTUNGEN - PET-KETTENGLEITER - TYP QV

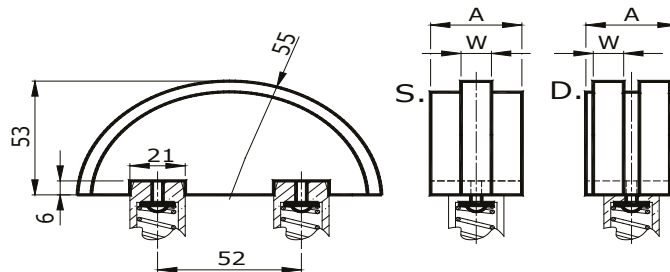

Material: PET-Kettengleiter mit hoher molekularer Dichte.
Rostfreie Bolzen.

Verwendung: Tiefer gelegtes, kreisrundes Profil konstruiert für mittleren bis langen Achsabstand.
Betriebsgeschwindigkeit $\leq 20\text{m/min}$.
Maximale Betriebstemperatur $70\text{ }^\circ\text{C}$.

Art. Nr.	Kette	A	W	Kg
QV 45	12-B1	33	11	0,08
QV 55	16-B1	33	16	0,08
QV 2 D	08-B2	33	7	0,08
QV 3 D	10-B2	33	9	0,09
QV 4 D	12-B2	33	11	0,10



KOMPLETTE AXIALE SPANNVORRICHTUNGEN TCD + KETTENGLEITER QG



Typ TCDZ mit Federn aus verzinktem Stahl
 Typ TCDX mit Federn aus rostfreiem Stahl

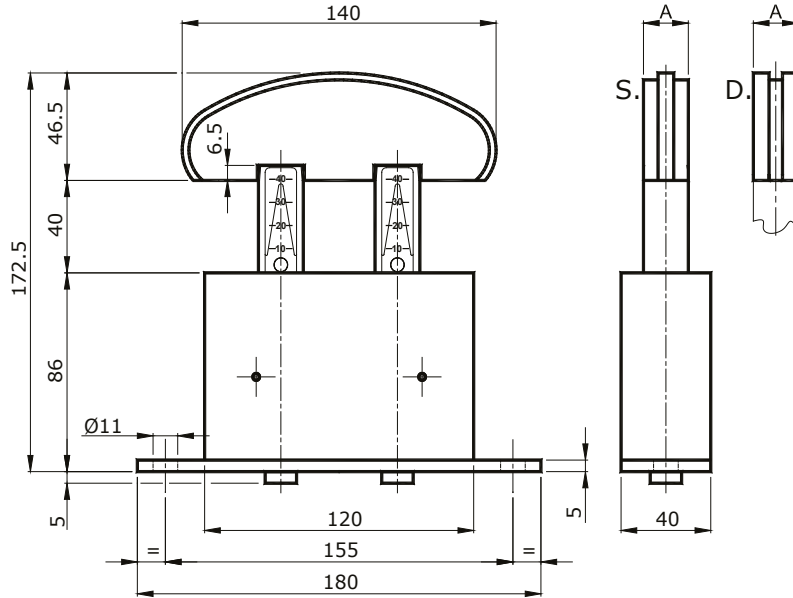

Kette DIN 8187 ISO	Mit Federn aus verzinktem Stahl			Mit Feder aus rostfreiem Stahl		
	TCDZ + QG	TCDZ	QG	TCDX	TCDX + QG	
						A

Kette DIN 8187 ISO	Teilenummer	Teilenummer	Teilenummer	Teilenummer	Teilenummer	Teilenummer	
05-B1	8mm	TCD10ZQG0S	TCD 10 Z	QG 0 S	20	TCD 10 X	TCD10XQG0S
06-B1	3/8"x7/32"	TCD10ZQG1S	TCD 10 Z	QG 1 S	20	TCD 10 X	TCD10XQG1S
06-B1	3/8"x7/32"	TCD20ZQG1S	TCD 20 Z	QG 1 S	20	TCD 20 X	TCD20XQG1S
08-B1	1/2"x5/16"	TCD10ZQG2S	TCD 10 Z	QG 2 S	20	TCD 10 X	TCD10XQG2S
08-B1	1/2"x5/16"	TCD20ZQG2S	TCD 20 Z	QG 2 S	20	TCD 20 X	TCD20XQG2S
10-B1	5/8"x3/8"	TCD20ZQG3S	TCD 20 Z	QG 3 S	20	TCD 20 X	TCD20XQG3S
10-B1	5/8"x3/8"	TCD30ZQG3S	TCD 30 Z	QG 3 S	20	TCD 30 X	TCD30XQG3S
12-B1	3/4"x7/16"	TCD30ZQG4S	TCD 30 Z	QG 4 S	20	TCD 30 X	TCD30XQG4S
16-B1	1"x17,02mm	TCD30ZQG5S	TCD 30 Z	QG 5 S	25	TCD 30 X	TCD30XQG5S
16-B1	1"x17,02mm	TCD40ZQG5S	TCD 40 Z	QG 5 S	25	TCD 40 X	TCD40XQG5S
20-B1	1"1/4x3/4"	TCD30ZQG6S	TCD 30 Z	QG 6 S	25	TCD 30 X	TCD30XQG6S
20-B1	1"1/4x3/4"	TCD40ZQG6S	TCD 40 Z	QG 6 S	25	TCD 40 X	TCD40XQG6S
24-B1	1"1/2x1"	TCD30ZQG7S	TCD 30 Z	QG 7 S	30	TCD 30 X	TCD30XQG7S
24-B1	1"1/2x1"	TCD40ZQG7S	TCD 40 Z	QG 7 S	30	TCD 40 X	TCD40XQG7S
05-B2	8mm	TCD10ZQG0D	TCD 10 Z	QG 0 D	20	TCD 10 X	TCD10XQG0D
06-B2	3/8"x7/32"	TCD10ZQG1D	TCD 10 Z	QG 1 D	20	TCD 10 X	TCD10XQG1D
06-B2	3/8"x7/32"	TCD20ZQG1D	TCD 20 Z	QG 1 D	20	TCD 20 X	TCD20XQG1D
08-B2	1/2"x5/16"	TCD20ZQG2D	TCD 20 Z	QG 2 D	20	TCD 20 X	TCD20XQG2D
10-B2	5/8"x3/8"	TCD20ZQG3D	TCD 20 Z	QG 3 D	25	TCD 20 X	TCD20XQG3D
10-B2	5/8"x3/8"	TCD30ZQG3D	TCD 30 Z	QG 3 D	25	TCD 30 X	TCD30XQG3D
12-B2	3/4"x7/16"	TCD30ZQG4D	TCD 30 Z	QG 4 D	30	TCD 30 X	TCD30XQG4D
16-B2	1"x17,02mm	TCD30ZQG5D	TCD 30 Z	QG 5 D	48	TCD 30 X	TCD30XQG5D
16-B2	1"x17,02mm	TCD40ZQG5D	TCD 40 Z	QG 5 D	48	TCD 40 X	TCD40XQG5D
20-B2	1"1/4x3/4"	TCD30ZQG6D	TCD 30 Z	QG 6 D	55	TCD 30 X	TCD30XQG6D
20-B2	1"1/4x3/4"	TCD40ZQG6D	TCD 40 Z	QG 6 D	55	TCD 40 X	TCD40XQG6D
24-B2	1"1/2x1"	TCD30ZQG7D	TCD 30 Z	QG 7 D	70	TCD 30 X	TCD30XQG7D
24-B2	1"1/2x1"	TCD40ZQG7D	TCD 40 Z	QG 7 D	70	TCD 40 X	TCD40XQG7D

Spannvorrichtungen für Dreifachketten nur auf Anfrage.



AXIALE SPANNVORRICHTUNGEN TCD + KETTENGLEITER QV

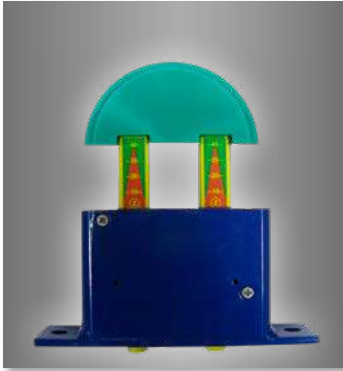

Typ TCDZ mit Federn aus verzinktem Stahl
 Typ TCDX mit Federn aus rostfreiem Stahl

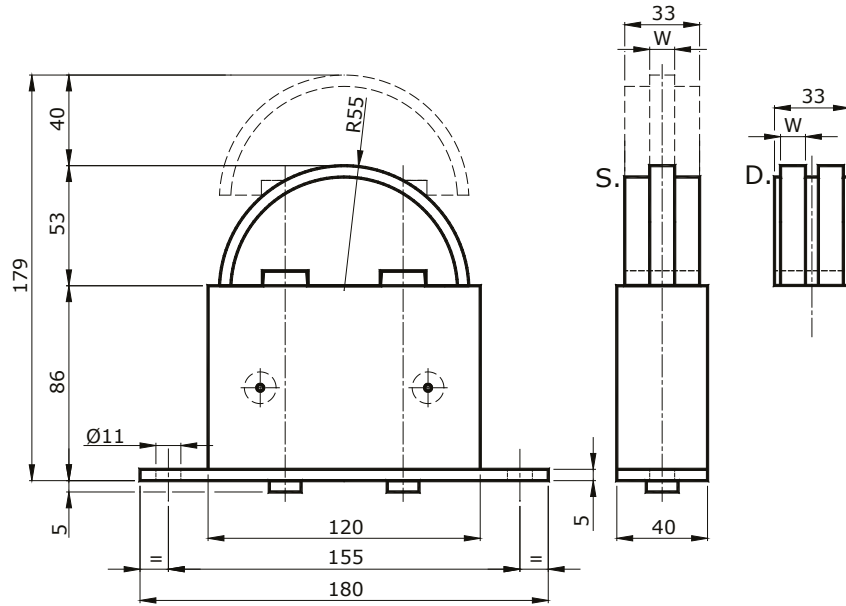

		Mit Federn aus verzinktem Stahl			Mit Feder aus rostfreiem Stahl		
Kette DIN 8187 ISO		TCDZ + QV	TCDZ	QV	TCDX	TCDX + QV	
						A	
12-B1	3/4"x7/16"	TCD20ZQV4S	TCD 20 Z	QV 4 S	11	TCD 20 X	TCD20XQV4S
12-B1	3/4"x7/16"	TCD30ZQV4S	TCD 30 Z	QV 4 S	11	TCD 30 X	TCD30XQV4S
16-B1	1"x17,02mm	TCD30ZQV5S	TCD 30 Z	QV 5 S	16	TCD 30 X	TCD30XQV5S
16-B1	1"x17,02mm	TCD40ZQV5S	TCD 40 Z	QV 5 S	16	TCD 40 X	TCD40XQV5S
08-B2	1/2"x5/16"	TCD20ZQV2D	TCD 20 Z	QV 2 D	7	TCD 20 X	TCD20XQV2D
10-B2	5/8"x3/8"	TCD20ZQV3D	TCD 20 Z	QV 3 D	9	TCD 20 X	TCD20XQV3D
10-B2	5/8"x3/8"	TCD30ZQV3D	TCD 30 Z	QV 3 D	9	TCD 30 X	TCD30XQV3D
12-B2	3/4"x7/16"	TCD30ZQV4D	TCD 30 Z	QV 4 D	11	TCD 30 X	TCD30XQV4D

Spannvorrichtungen für Dreifachketten nur auf Anfrage.



TECHNISCHE DATEN - MONTAGEANLEITUNG

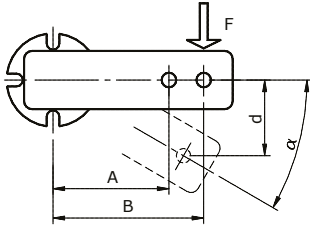

Typ	Vorbelastungswinkel $\alpha < 10^\circ\text{C}$				Vorbelastungswinkel $\alpha < 20^\circ\text{C}$				Vorbelastungswinkel $\alpha < 30^\circ\text{C}$			
	A	B	A	B	A	B	A	B	A	B	A	B
	F [N]	d [mm]	F [N]	d [mm]	F [N]	d [mm]	F [N]	d [mm]	F [N]	d [mm]	F [N]	d [mm]
BT 11 / BTF 11	15	14	20	10	40	28	53	20	84	40	113	30
BT 15 / BTF 15	25	17	31	14	65	34	81	27	136	50	170	40
BT 18 / BTF 18	75	17	93	14	180	34	225	27	340	50	425	40
BT 27 / BTF 27	150	22	195	17	380	44	494	34	790	65	1027	50
BT 38 / BTF 38	290	30	362	24	730	60	912	47	1600	87	2000	70
BT 45 / BTF 45	500	39	625	31	1300	78	1625	61	2550	112	3190	90
BT 50 / BTF 50	600	43	750	34	1700	86	2125	68	4000	125	5000	100

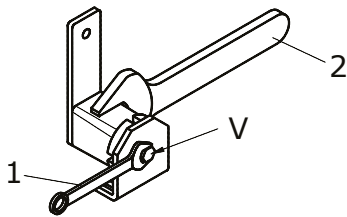

Um die Spannvorrichtung vorzubelasten, lockern Sie die Schraube mit Hilfe des Schlüssels Rep 1. Danach drehen Sie das Gehäuse mit Schlüssel Rep 2, bis Sie den gewünschten Winkel erreicht haben. Danach ziehen Sie die Schraube V mit jenem Anzugsmoment fest, das in der Tabelle angegeben wird.

Typ	Anzugsmoment in Nm						
	Größe						
	11	15	18	27	38	45	50
BT	10	25	49	89	210	410	750
BTF	7	17	41	83	145	355	690

TECHNISCHE DATEN - MONTAGEBEISPIELE

MONTAGE RICHTIG!

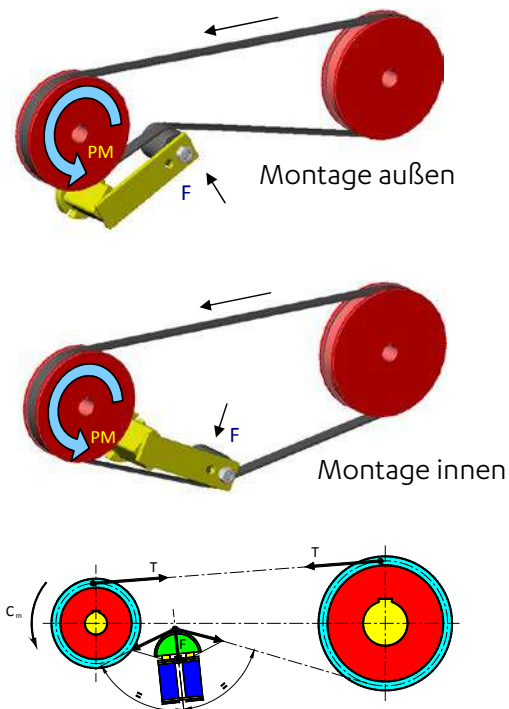

MONTAGE FALSCH!

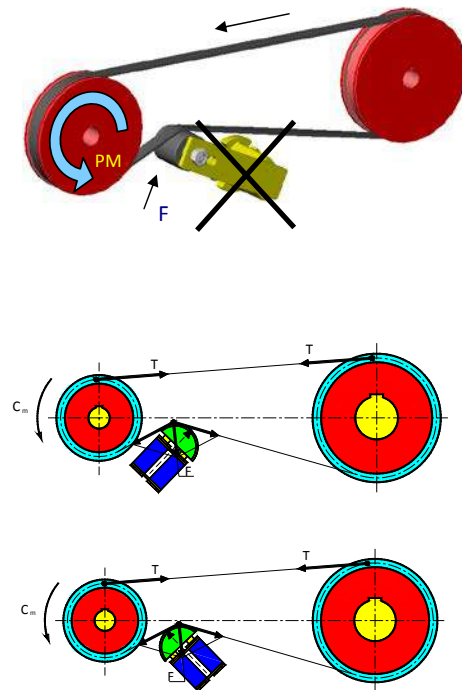

sedis 



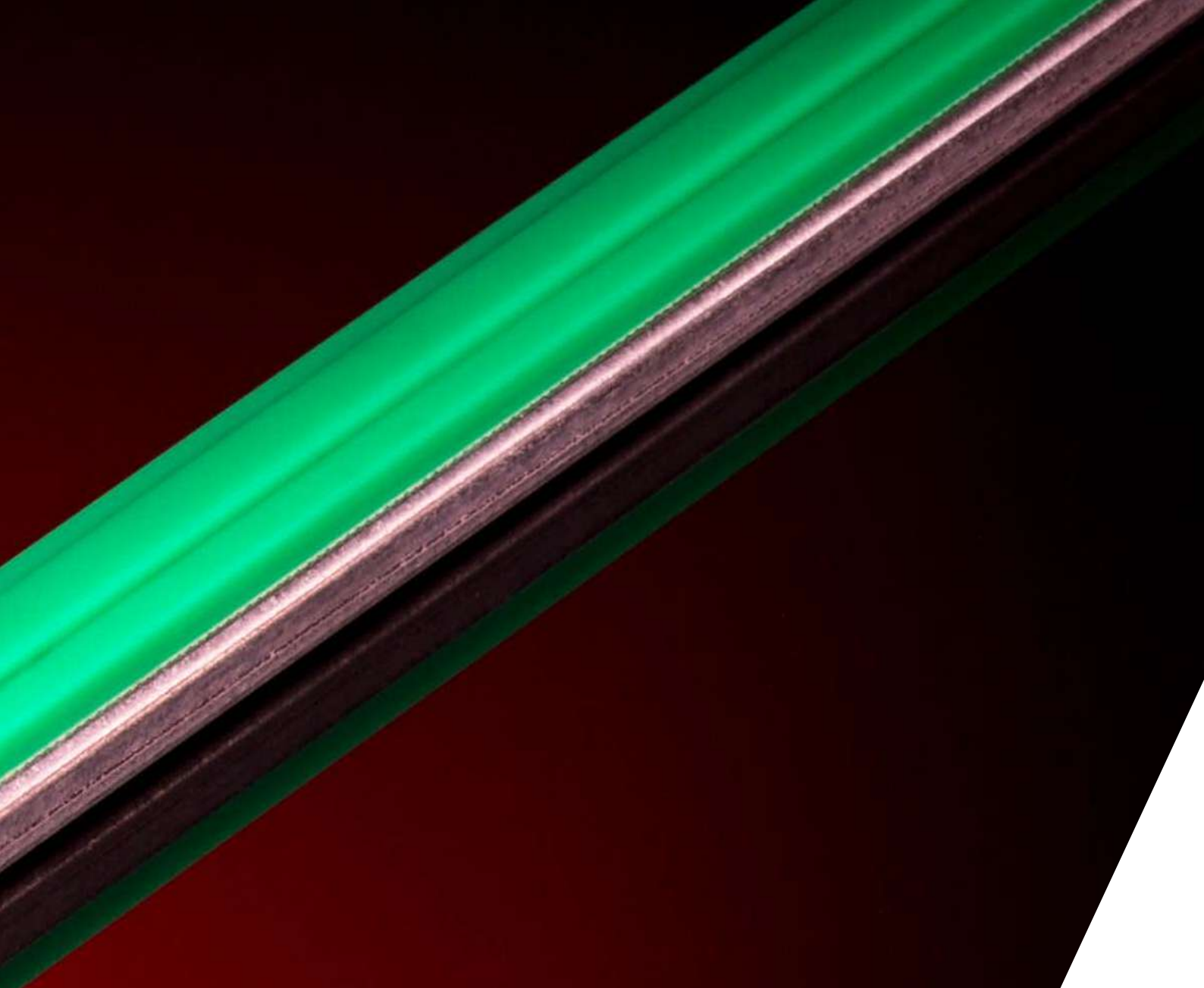

KETTEN- UND RIEMENFÜHRUNGEN

KETTENFÜHRUNGEN PEHD GRÜN

Die Kettenführungen und die Schienen werden in Längen zu 2 Metern geliefert. Auf Wunsch können Sonderlängen angefertigt werden.

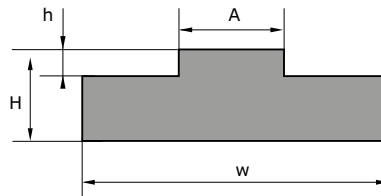

MS			W	H	A	h	Kg/m
Art. Nr.	ISO	Teilung					
MS-1	06B-1	9,525	15	10	5,5	1,5	0,135
MS-2	08B-1	12,7	20	10	7,5	2,2	0,165
MS-215	08B-1	12,7	20	15	7,5	2,2	0,260
MS-220	08B-1	12,7	20	20	7,4	2,2	0,350
MS-3	10B-1	15,875	20	10	9,3	2,6	0,160
MS-315	10B-1	15,875	20	15	9,3	2,6	0,260
MS-320	10B-1	15,875	20	20	9,3	2,6	0,350
MS-4	12B-1	19,05	25	10	11,3	2,4	0,210
MS-415	12B-1	19,05	25	15	11,3	2,4	0,325
MS-420	12B-1	19,05	25	20	11,3	2,4	0,440
MS-5	16B-1	25,4	40	15	16,5	3,5	0,470
MS-520	16B-1	25,4	40	20	16,5	3,5	0,660
MS-6	20B-1	31,75	45	15	19	4,2	0,530
MS-620	20B-1	31,75	45	20	19	4,3	0,720
MS-7	24B-1	38,1	60	15	24,7	5,5	0,785
MS-8	28B-1	44,45	75	20	30,0	6,8	1,130
MS-9	32B-1	50,8	80	20	30,0	7,7	1,210

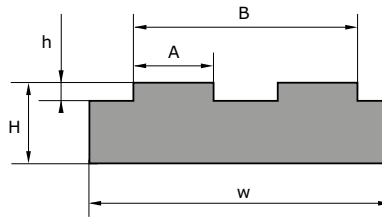
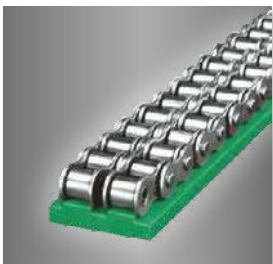

MD			W	H	A	h	B	Kg/m
Art. Nr.	ISO	Teilung						
MD-1	06B-2	9,525	25	10	5,4	1,5	15,70	0,230
MD-2	08B-2	12,7	35	10	7,5	2,2	21,4	0,306
MD-215	08B-2	12,7	35	15	7,5	2,2	21,4	0,530
MD-3	10B-2	15,875	40	10	9,3	2,6	25,9	0,344
MD-315	10B-2	15,875	40	15	9,2	2,6	26	0,524
MD-4	12B-2	19,05	45	10	11,3	2,4	30,8	0,396
MD-415	12B-2	19,05	45	15	11,3	2,4	30,8	0,598
MD-5	16B-2	25,4	65	15	16,5	3,5	48,3	0,863
MD-520	16B-2	25,4	65	20	16,5	3,5	48,3	1,156
MD-6	20B-2	31,75	70	15	19	4,3	54,5	0,912
MD-620	20B-2	31,75	70	20	19	4,3	54,5	1,232
MD-7	24B-2	38,1	88	20	24,6	5,6	72,9	1,499
MD-8	28B-2	44,45	88,4	25	28,8	6,8	88,4	1,790
MD-9	32B-2	50,8	87,4	30	28,8	7,7	87,4	1,750



KETTENFÜHRUNGEN PEHD GRÜN

Die Kettenführungen und die Schienen werden in Längen zu 2 Metern geliefert. Auf Wunsch können Sonderlängen angefertigt werden.

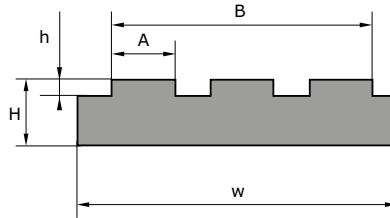
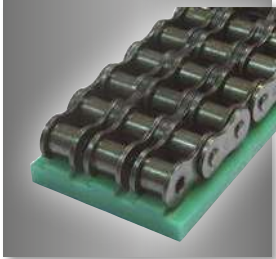

MT			W	H	A	h	B	Kg/m
Art. Nr.	ISO	Teilung						
MT-1	06B-3	9,525	35	10	5,4	1,5	25,9	0,306
MT-2	08B-3	12,7	45	10	7,4	2,2	35,3	0,381
MT-215	08B-3	12,7	45	15	7,4	2,2	35,3	0,595
MT-220	08B-3	12,7	45	20	7,4	2,2	35,3	0,808
MT-3	10B-3	15,875	55	10	9,2	2,6	42,4	0,455
MT-4	12B-3	19,05	60	15	11,3	2,4	50,3	0,546
MT-5	16B-3	25,4	95	20	16,5	3,5	80,3	1,167
MT-6	20B-3	31,75	105	15	19	4,2	92,0	1,304
MT-7	24B-3	38,1	135	20	24,7	5,5	121,5	2,247
MT-8	28B-3	44,45	170	25	30,1	6,8	149,3	3,522
MT-9	32B-3	50,8	170	30	30,1	7,7	149,3	4,262

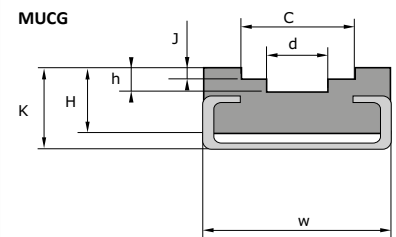
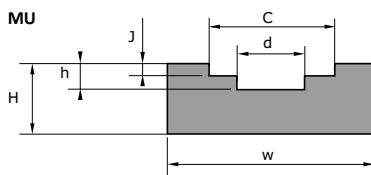
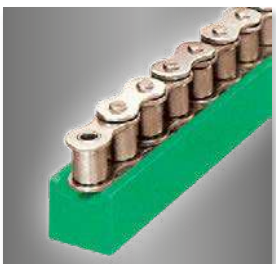

MU & MUCG											
Art. Nr.	ISO	Teilung	W	H	C	h	J	d	K	Profil	Kg/m
MU-1	06B-1	9,525	20	15	9,2	4,2	2,8	4			0,257
MU-2	08B-1	12,7	25	15	12,7	4,8	3,5	5			0,308
MU-3	10B-1	15,875	25	15	15,2	5,1	3,6	6			0,296
MU-4	12B-1	19,05	25	20	16,7	5,7	3,9	7			0,403
MU-5	16B-1	25,4	35	25	24,4	10	8,4	9			0,624
MUCG-1*	06B-1	9,525	20	14	9,4	4,2	2,8	4	17	C2010	0,720
MUCG-2*	08B-1	12,7	20	24	12,8	5	3,5	5	11	C2812	1,140
MUCG-3*	10B-1	15,875	24	28	15,4	5	3,6	6	18	C2812	1,130
MUCG-4*	12B-1	19,05	24	28	17	5,7	3,9	7	18	C2812	1,270
MUCG-5*	16B-1	25,4	33	38	24	10,6	8,4	9	30	C3818	2,030

* Geben Sie die Art. Nr./ENS an, um die Führung und das Profil zu erhalten.



KETTENFÜHRUNGEN PEHD GRÜN

Die Kettenführungen und die Schienen werden in Längen zu 2 Metern geliefert. Auf Wunsch können Sonderlängen angefertigt werden.

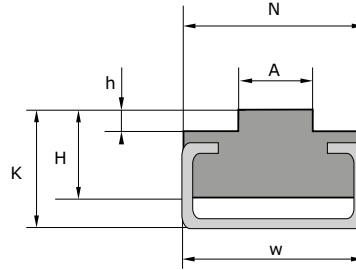
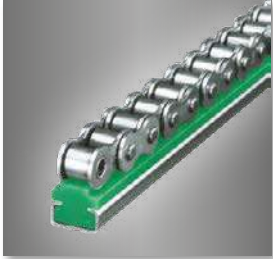

MTCG			W	N	H	K	h	A	Profil	Kg/m
Art. Nr. Führungen	ISO	Teilung								
MTCG-1*	06B-1	9,525	20		15	17	1,5	5,4	C2010	0,620
MTCG-2*	08B-1	12,7	20	17	15	17	2,2	7,5	C2010	0,695
MTCG-3*	10B-1	15,875	20	17	15	17	2,6	9,3	C2010	0,700
MTCG-4*	12B-1	19,05	28	23,5	15	18	2,4	11,3	C2812	1,170
MTCG-4/20*	12B-1	19,05	20	20	15	17	2,4	11,3	C2010	0,830
MTCG-5*	16B-1	25,4	28	23,5	15	18	3,5	16,5	C2812	2,245
MTCG-6*	20B-1	31,75	28	28	15	18	4,3	19	C2812	2,305
MTCG-7*	24B-1	38,1	38	33	25	30	5,5	24,7	C3818	2,390
MTCG-8*	28B-1	44,45	38	38	23	30	6,8	30	C05	2,410
MTCG-9*	32B-1	50,8	38	38	23	30	7,7	30	C05	2,480

* Geben Sie die Art. Nr./ENS an, um die Führung und das Profil zu erhalten.

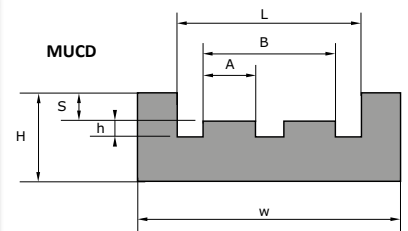
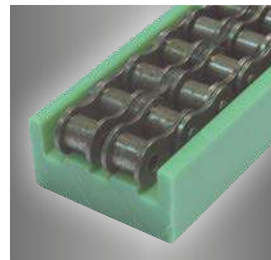
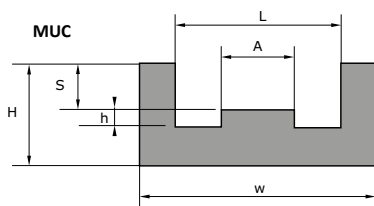
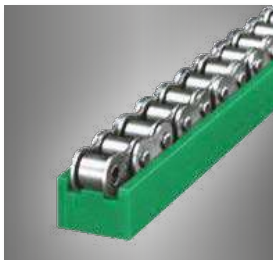

MUC & MUCD			W	H	L	h	A	S	B	Kg/m
Art. Nr. Führungen	ISO	Teilung								
MUC-1	06B-1	9,525	25	10	15	1,5	5,4	4,4		0,170
MUC-2	08B-1	12,7	30	15	20	2,2	7,4	7,2		0,275
MUC-3	10B-1	15,875	33	20	23	2,6	9,2	9,5		0,405
MUC-4	12B-1	19,05	38	20	28	2,4	11,3	11,2		0,410
MUC-5	16B-1	25,4	51	25	41	3,5	16,5	16,5		0,510
MUCD-1	06B-2	9,525	36	15	26	1,5	5,4	4,4	16	0,390
MUCD-2	08B-2	12,7	45	20	35	2,2	7,4	7,2	21	0,620
MUCD-3	10B-2	15,875	50	25	40	2,6	9,2	9,5	26	0,816
MUCD-4	12B-2	19,05	56	25	46	2,4	11,3	11,1	31	0,810
MUCD-5	16B-2	25,4	85	30	75	3,5	16,5	16,5	48	1,200



KETTENFÜHRUNGEN PEHD GRÜN

Die Kettenführungen und die Schienen werden in Längen zu 2 Metern geliefert. Auf Wunsch können Sonderlängen angefertigt werden.

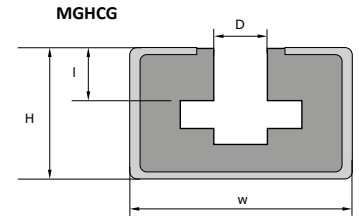
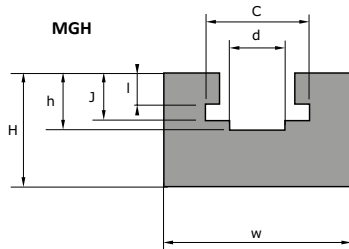
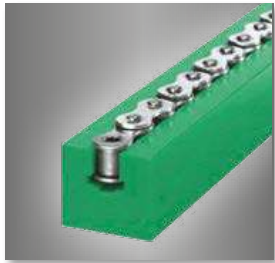

MGH & MGHC

Art. Nr. Führungen	ISO	Teilung	W	H	C	h	I	d	J	Profil	Kg/m
MGH-1	06B-1	9,525	20	25	9,3	9,9	5,5	4	8,7		0,414
MGH-2	08B-1	12,7	24	30	12,8	12,7	7,5	5	11,5		0,564
MGH-3	10B-1	15,875	30	35	15,4	14,8	9,3	6	13,5		0,832
MGH-4	12B-1	19,05	40	35	16,9	17,5	11,3	7,9	15,9		1,106
MGH-5	16B-1	25,4	40	45	24,4	27	16,5	9	25,7		1,231
MGH-6	20B-1	31,75	50	50	28	31,7	18	11	29,5		1,726
MGH-7	24B-1	38,1	60	60	36,5	41,2	24	16	38,2		2,332
MGH-8	28B-1	44,45	60	70	41	49	30	17	47		3,173
MGH-9	32B-1	50,8	70	75	44,5	50	30	19	47,3		3,264
MGHCG-1*	06B-1	9,525	30	24			5,6			C3024	2,150
MGHCG-2*	08B-1	12,7	30	24			7,6			C3024	2,150
MGHCG-2E*	08B-1	12,7	28	16			7,6			C2816	2,100
MGHCG-3*	10B-1	15,875	30	24			9,3			C3024	2,100
MGHCG-4*	12B-1	19,05	30	24			11,3			C3024	2,060
MGHCG-5*	16B-1	25,4	45	40			16,5			C4540	2,060

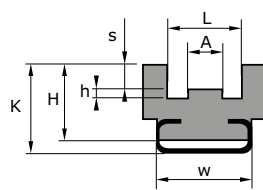

MUCCG

Art. Nr. Führungen	ISO	Teilung	W	H	K	L	h	A	S	Profil	Kg/m
MUCCG-1*	06B-1	9,525	20	14	17	13	1,5	3,8	1,1	C2010	0,760
MUCCG-2*	08B-1	12,7	20	16	20	16,3	2,2	5,7	1,6	C2010	1,100
MUCCG-3*	10B-1	15,875	28	16	20	19,2	2,6	7,4	2,1	C2812	1,305
MUCCG-4*	12B-1	19,05	28	18	22	21,8	2,4	9,2	2,8	C2812	2,335
MUCCG-5*	16B-1	25,4	38	25	30	35	3,5	15	3,3	C3818	2,440

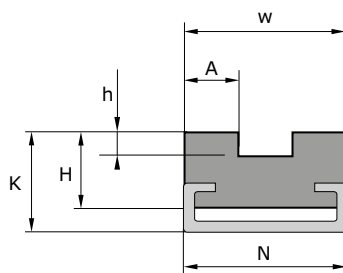
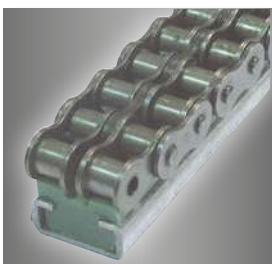

MTCGD

Art. Nr. Führungen	ISO	Teilung	W	N	H	K	h	A	Profil	Kg/m
MTCGD-1*	06B-2	9,525	15,5	20	14	17	1,5	5,4	C2010	0,615
MTCGD-2*	08B-2	12,7	21,4	20	15	17	2,2	7,5	C2010	0,715
MTCGD-3*	10B-2	15,875	25,7	20	15	17	2,6	9,3	C2010	1,165
MTCGD-4*	12B-2	19,05	30,7	28	15	20	2,4	11,3	C2812	1,200
MTCGD-5*	16B-2	25,4	48	38	20	27	3,5	16,5	C3818	1,170
MTCGD-6*	20B-2	31,75	55	38	25	30	4,3	19	C3818	2,480
MTCGD-7*	24B-2	38,1	72	38	30	35	5,5	24,7	C3818	3,020

* Geben Sie die Art. Nr./ENS an, um die Führung und das Profil zu erhalten.

KETTENFÜHRUNGEN PEHD GRÜN

Die Kettenführungen und die Schienen werden in Längen zu 2 Metern geliefert. Auf Wunsch können Sonderlängen angefertigt werden.

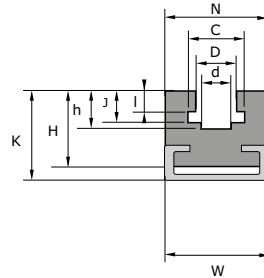

MGHLCG

Art. Nr. Führungen	ISO	Teilung	W	N	H	K	I	J	h	d	D	C	Profil	Kg/m
MGHLCG-1*	06B-1	9,525	20	20	17,5	21	5,5	8,7	10	4	6,6	9,4	C2010	0,622
MGHLCG-2*	08B-1	12,7	28	24	28	32	7,4	11,5	13	5	8,7	12,8	C2816	1,450
MGHLCG-3*	10B-1	15,875	28	24	28	32	9,3	13,5	14,8	6	10,4	15,4	C2816	1,402
MGHLCG-4*	12B-1	19,05	38	32	35	43	11,3	15,9	17,5	7	12,3	17	C3818	1,709
MGHLCG-5*	16B-1	25,4	38	40	45	50	16	25,7	27,7	10	16,4	24	C3818	1,600
MGHLCG-6*	20B-1	31,75	60	60	50	55	18	29,3	31,7	11	20	28	C6020	4,800
MGHLCG-7*	24B-1	38,1	60	60	60	65	24	38,2	41,2	16	27	36,6	C6020	5,000
MGHLCG-8*	28B-1	44,45	60	70	75	80	30	46,9	49	17	30	40	C6020	6,200
MGHLCG-9*	32B-1	50,8	60	70	75	80	30	47,3	50	19	31	44,6	C6020	6,200

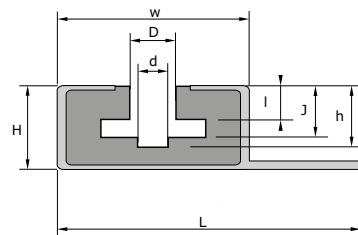
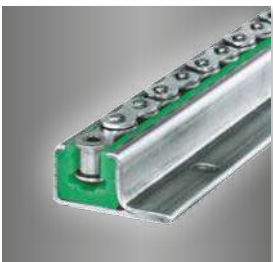

MGHPGC

Art. Nr. Führungen	ISO	Teilung	H	W	L	I	J	h	d	D	Profil	Kg/m
MGHPGC-1*	06B-1	9,525	25	31	53	5,6	8,7	9,9	4	6,6	C15	2,340
MGHPGC-2*	08B-1	12,7	25	31	53	7,6	11,5	12,7	5	8,7	C15	2,300
MGHPGC-3*	10B-1	15,875	25	31	53	9,3	13,5	14,8	6	10,4	C15	2,250
MGHPGC-4*	12B-1	19,05	25	31	53	11,5	15,9	17,5	7	12,3	C15	2,250

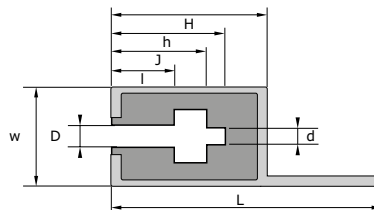

MGHGCG

Art. Nr. Führungen	ISO	Maß	H	W	L	I	J	h	d	D	Profil	Kg/m
MGHGCG-1*	06B-1	9,525	25	31	47	5,6	8,7	9,9	4	6,6	C14	2,150
MGHGCG-2*	08B-1	12,7	25	31	47	7,6	11,5	12,7	5	8,7	C14	2,150
MGHGCG-3*	10B-1	15,875	25	31	47	9,3	13,5	14,8	6	10,4	C14	2,100
MGHGCG-4*	12B-1	19,05	25	31	47	11,5	15,9	17,5	7	12,3	C14	2,060



KETTENFÜHRUNGEN PEHD GRÜN

Die Kettenführungen und die Schienen werden in Längen zu 2 Metern geliefert. Auf Wunsch können Sonderlängen angefertigt werden.

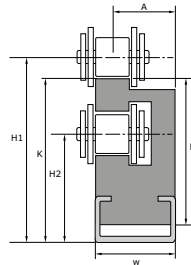

M2PCG

Art. Nr. Führungen	ISO	Teilung	W	H1	H2	A	K	H	Profil	Kg/m
M2PCG-1*	06B-1	9,525	20	31,6	19,5	17,3	28,4	26,4	C2010	0,900
M2PCG-2*	08B-1	12,7	20	33,8	18	16,5	30	287	C2010	0,960
M2PCG-3*	10B-1	15,875	20	41,1	21	15,5	36	33	C2010	1,120
M2PCG-4*	12B-1	19,05	28	46,5	24	18,6	41	37	C2812	1,700
M2PCG-5*	16B-1	25,4	38	69,4	34	29,7	61,4	52,4	C3818	3,100

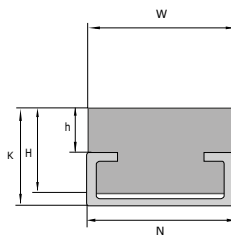
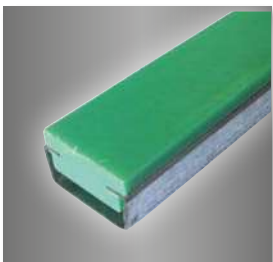

MHCG

Art. Nr. Führungen	W	N	K	H	h	Profil	Kg/m
MHCG-2006*	20	24	6	5	1	C2405	0,350
MHCG-2011*	20	24	11	10	5,8	C2405	0,450
MHCG-2014*	20	20	14	10	4	C2010	0,790
MHCG-2017*	20	20	17	15	7	C2010	0,880
MHCG-2022*	20	20	20	18	10	C2010	0,940
MHCG-2815*	28	28	15	10	3	C2812	1,180
MHCG-2818*	28	28	18	15	6	C2812	1,320
MHCG-2824*	28	28	24	20	12	C2812	1,488
MHCG-3822*	38	38	22	15	4	C3818	2,200
MHCG-3824*	38	38	24	20	7	C3818	2,460
MHCG-3830*	38	38	30	20	12	C3818	2,690
MHCG-6030*	60	60	30	20	10	C6020	3,260

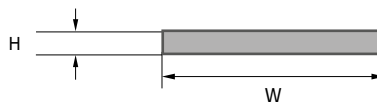
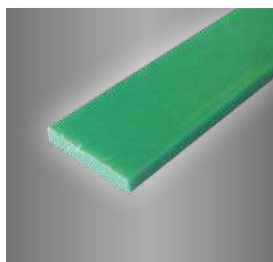

GR

Art. Nr.	Teilung	20	25	30	35	40	45	50	60	70	80	90	100
GR..X2	2	0,86	1,12	1,33	1,59	1,77	2,02	2,20	2,63	3,10	3,53	3,96	4,39
GR..X3	3	1,33	1,64	2,02	2,28	2,63	3,01	3,31	3,96	4,65	5,30	5,98	6,59
GR..X5	5	2,20	2,76	3,31	3,87	4,39	4,99	5,51	6,59	7,71	8,78	9,90	10,98



SCHWARZE, ANTISTATISCHE PEHD-RIEMENFÜHRUNGEN

Die Kettenführungen und die Schienen werden in Längen zu 2 Metern geliefert. Auf Wunsch können Sonderlängen angefertigt werden.

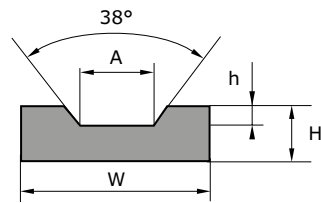

MCT

Art. Nr.	W	H	h	A	Kg/m
Führungen					
MCT-10Z	20	10	3,5	6	0,197
MCT-13A	20	12	6	9,2	0,232
MCT-15E	25	12	5	10,0	0,292
MCT-17B	30	15	8	10,5	0,429
MCT-22C	35	20	11	13,5	0,660
MCT-30D	40	25	13	19,0	0,944

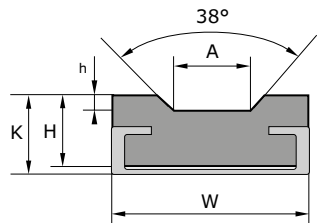

MCTCG

Art. Nr.	W	H	h	K	A	Profil	Kg/m
Führungen							
MCTCG-10Z*	20	15	3	17	6,5	C2010	0,787
MCTCG-13A*	20	15	5	17	8,0	C2010	0,782
MCTCG-15E*	25	20	5	24	10,0	C2812	1,352
MCTCG-17B*	30	20	8	24	10,5	C2812	1,439
MCTCG-22C*	38	25	11	32	13,5	C3818	2,265
MCTCG-30D*	40	30	13	35	19,0	C05	2,574

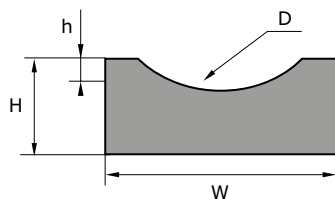

MCOR

Art. Nr.	D	W	H	h	Kg/m
Führungen					
MCOR-04	4	15	10	2,0	0,144
MCOR-05	5	15	10	2,5	0,140
MCOR-06	6	20	10	3,0	0,186
MCOR-08	8	20	10	4,0	0,175
MCOR-10	10	25	12	5,0	0,260
MCOR-12	12	25	12	6,0	0,244
MCOR-15	15	25	15	7,5	0,286
MCOR-20	20	30	20	10,0	0,442

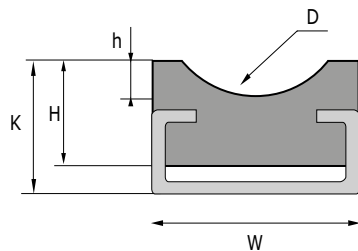

MCORCG

Art. Nr.	D	W	H	h	K	Profil	Kg/m
Führungen							
MCORCG-04*	4	20	10	2	14	C2010	0,680
MCORCG-05*	5	20	10	2,5	14	C2010	0,675
MCORCG-06*	6	20	10	3	14	C2010	0,660
MCORCG-08*	8	20	10	4	14	C2010	0,650
MCORCG-10*	10	28	15	5	18	C2812	1,179
MCORCG-12*	12	28	15	6	18	C2812	1,160
MCORCG-15*	15	28	15	7,5	18	C2812	1,160
MCORCG-20*	20	28	20	10	24	C2812	1,280

* Geben Sie die Art. Nr./ENS an, um die Führung und das Profil zu erhalten.



PROFILE / SCHIENEN - VERZINKTER STAHL ODER EDELSTAHL

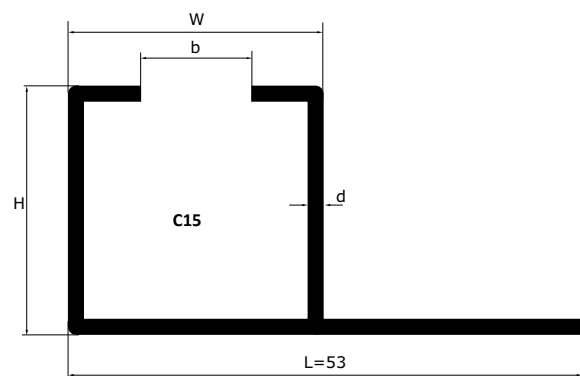
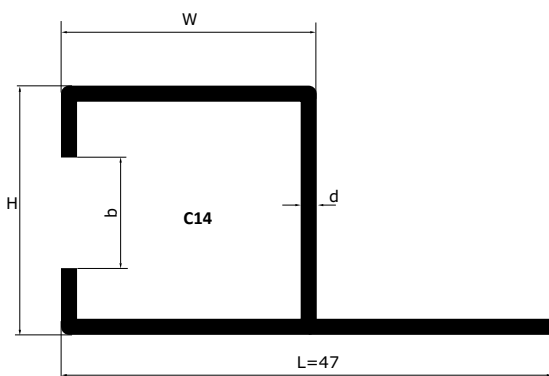
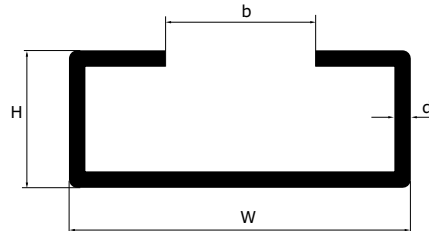

Lochung der Schiene zur Befestigung des Profils C14 und C15.

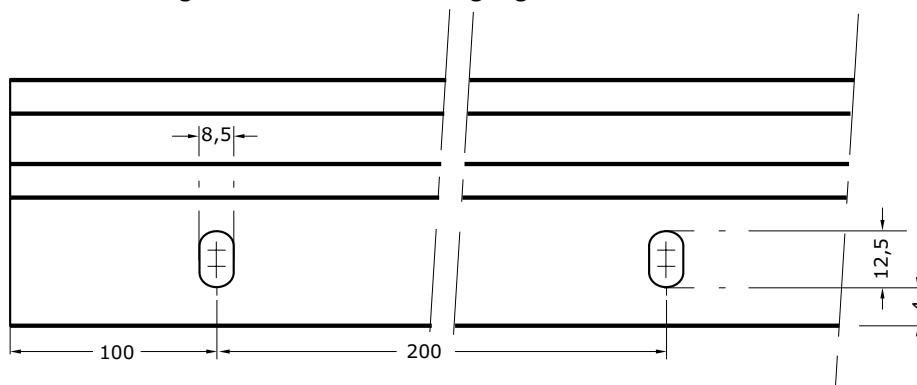

Art. Nr.		W	H	b	d	Kg/m
VERZINKT	ROSTFREI					
C2405	C2405IN	24	5,2	17,5	1	0,28
C2010	C2010IN	20	10	10,0	1 / 1,5	0,43
C2812	C2812IN	28	12	14,0	2,2	0,95
C2816	C2816IN	28	16	14,0	2,3	1,15
C3818	C3818IN	38	18	22,0	1,5	0,98
C3024	C3024IN	30	24	20,0	1,5	0,94
C3818	C3818IN	38	18	22,0	2,5	1,43
C4540	C4540IN	45	40	31,0	2	2,05
C6020	C6020IN	60	20	36,0	2,5	2,16
C2815	C2815IN	28	15	12,0	2,3	1,15
C-14	C47IN / 31 / 25	25	31	20,0	2	1,20
C-15	C53IN / 31 / 25	31	25	20,0	2	1,20

sedis 





SCHARNIERBANDKETTEN



EINFACH-SCHARNIER, GERADEGÄNGIG, SCHMALE AUSFÜHRUNG



Unsere Ketten werden nach der französischen Norm E26-108 und der deutschen Norm DIN 8153 gefertigt. Sie sind sowohl in vergütetem Stahl (AD) als auch Edelstahl erhältlich.

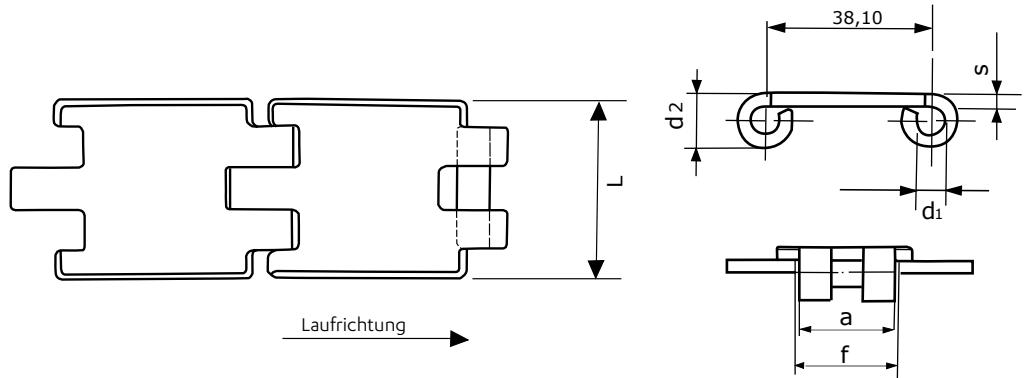

Art. Nr.	Bolzen- durchmesser <i>d1</i>	Bolzenlänge <i>a</i>	Breite <i>L</i>	Laschen- dicke <i>s</i>	Außendurchmesser Scharnierauge <i>d2</i>	Vorzusehender Abstand mit Seitenführung <i>f</i>	Gewicht pro Meter <i>Kg</i>
CCNP0320	6,35	21,75	32	3	13	23,75	1,1
CCNP0450	6,35	21,75	45	3	13	23,75	1,3

EINFACH-SCHARNIER, GERADEGÄNGIG

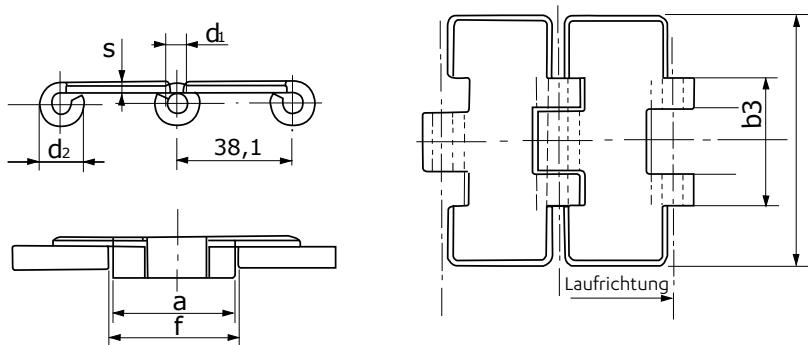

Art. Nr.	Bolzen- durchmesser <i>d1</i>	Bolzenlänge <i>a</i>	Breite <i>L</i>	Laschen- dicke <i>s</i>	Außendurchmesser Scharnierauge <i>d2</i>	Vorzusehender Abstand mit Seitenführung <i>f</i>	Gewicht pro Meter <i>in kg</i>
CCNP0635	6,35	42,5	63,5	3	13	44,5	2,25
CCNP0762	6,35	42,5	76,2	3	13	44,5	2,5
CCNP0826	6,35	42,5	82,6	3	13	44,5	2,65
CCNP0889	6,35	42,5	88,9	3	13	44,5	2,75
CCNP0952	6,35	42,5	95,2	3	13	44,5	2,75
CCNP1016	6,35	42,5	101,6	3	13	44,5	3
CCNP1143	6,35	42,5	114,3	3	13	44,5	3,3
CCNP1270	6,35	42,5	127	3	13	44,5	3,5
CCNP1524	6,35	42,5	152,4	3	13	44,5	4,2
CCNP1905	6,35	42,5	190,5	3	13	44,5	5,1



DOPPEL-SCHARNIER, GERADEGÄNGIG

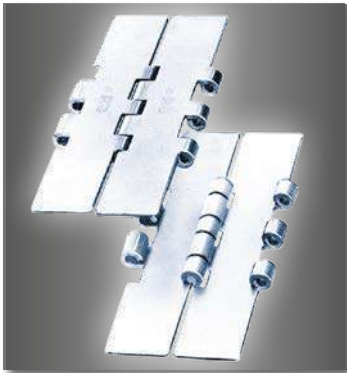

Unsere Ketten werden nach der französischen Norm E26-108 und der deutschen Norm DIN 8153 gefertigt. Sie sind sowohl in vergütetem Stahl (AD) als auch Edelstahl erhältlich.

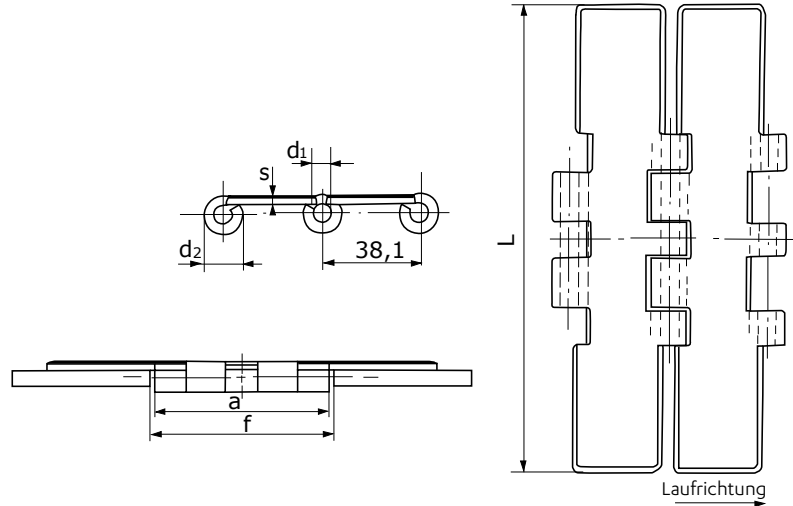

Art. Nr.	Bolzen- durchmesser <i>d1</i>	Bolzenlänge <i>a</i>	Breite <i>L</i>	Laschen- dicke <i>s</i>	Außendurchmesser Scharnierauge <i>d2</i>	Vorzusehender Abstand mit Seitenführung <i>f</i>	Gewicht pro Meter <i>Kg</i>
CCRP1270	6,35	80,5	127	3	13	82,5	5
CCRP1524	6,35	80,5	152,4	3	13	82,5	5,3
CCRP1905	6,35	80,5	190,5	3	13	82,5	5,8

EINFACH-SCHARNIER, KURVENGÄNGIG - MIT FÜHRUNGSSTEGEN TYPE E

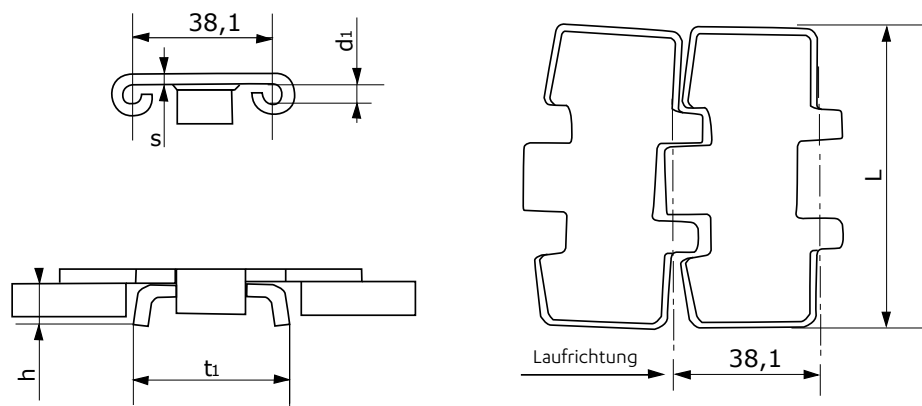

Art. Nr.	Bolzen- durchmesser <i>d1</i>	Breite <i>L</i>	Laschen- dicke <i>s</i>	Breite Führungssteg <i>t1</i>	Höhe des Bügels <i>h</i>	Krümmungs- Radius Minimum <i>mm</i>	Gewicht pro Meter <i>Kg</i>
CCBE0826	6,35	82,6	3	43	11,2	457	2,9
CCBE1143	6,35	114,3	3	43	11,2	500	3,6
CCBE1905	6,35	190,5	3	43	11,2	500	5,3



EINFACH-SCHARNIER, KURVENGÄNGIG - MIT NIEDERHALTERN TYPE T



Unsere Ketten werden nach der französischen Norm E26-108 und der deutschen Norm DIN 8153 gefertigt.
Sie sind sowohl in vergütetem Stahl (AD) als auch Edelstahl erhältlich.

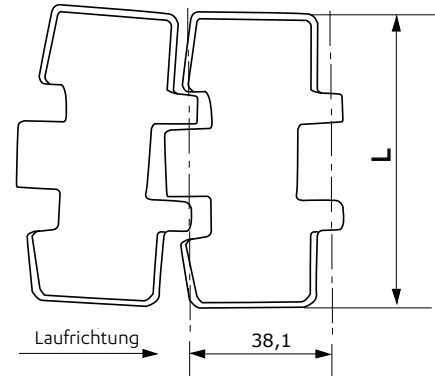
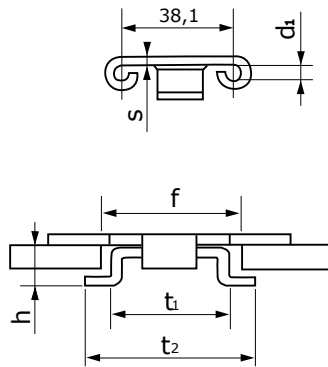

Art. Nr.	Bolzen- durchmesser <i>d1</i>	Breite <i>L</i>	Laschen- dicke <i>s</i>	Breite Führungssteg <i>t1</i>	Breite Niederhalter <i>t2</i>	Höhe des Bügels <i>h</i>	Krümmungs- Radius Minimum <i>mm</i>	Gewicht pro Meter <i>Kg</i>
CCBT0826	6,35	82,6	3	43	56,2	16,3	457	3,1
CCBT1143	6,35	114,3	3	43	56,2	16,3	500	3,8
CCBT1905	6,35	190,5	3	43	56,2	16,3	500	5,5

KURVENGÄNGIGE KETTE MIT EINEM RADIUS VON 200 MM - MIT FÜHRUNGSZUNGEN TYP T

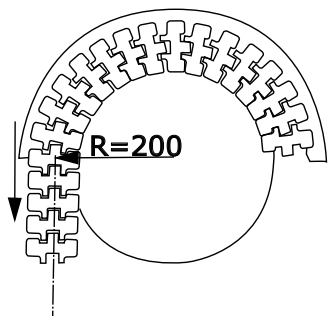
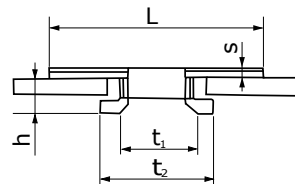
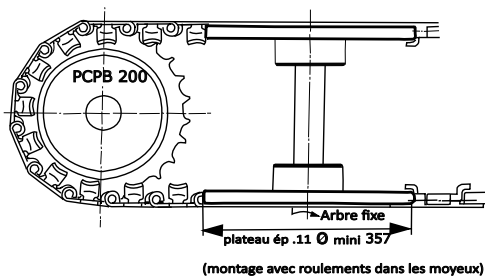

Art. Nr.	Bolzen- durchmesser <i>d1</i>	Breite <i>L</i>	Laschen- dicke <i>s</i>	Breite Führungssteg <i>t1</i>	Breite Niederhalter <i>t2</i>	Höhe des Bügels <i>h</i>	Krümmungs- Radius Minimum <i>mm</i>	Gewicht pro Meter <i>Kg</i>
CCCT0826	6,35	82,6	3	43	56,2	16,3	200	3



KETTENRÄDER FÜR SCHARNIERBANDKETTEN

Erhältlich in Stahl, gehärtetem Stahl und rostfreiem Stahl AISI 430

- Alle Zähne sind gefräst (das Fräsen wird durchgeführt, damit die Kette versetzt greift. Dies verdoppelt die Lebensdauer des Kettenrades.)
- Vorhandene Bohrung 19H10

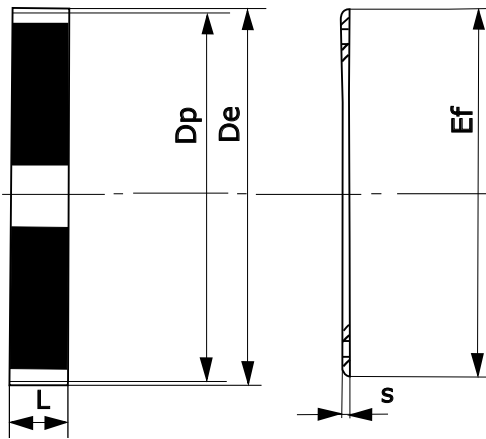

Auf Wunsch:

- Maschinelle Bearbeitung :
 - Bohrung
 - Abgesetzte Bohrung für Kugellageraufnahme
 - Passfedernut
 - Gleitlager
 - Gewindebohrung...
- Fertigung von Spezialkettenrad laut Plan, wenn die Anzahl der Zähne in der Tabelle nicht angeführt ist.
- Montage von Führungsflanschen

Anzahl der Zähne Z	Teilkreisdurchmesser Dp	Außendurchmesser De	Breite (mm)		Gewicht		Flansche		
			Kurvengängig schmal R=200 L	Gerade, normal L	Schmal Seitliche Biegung Biegung R 200 Kg	Gerade, normal Kg	Außendurchmesser Ef	Stärke s	Gewicht Kg
19	117,1	117,35	31	43,5	3,05	2,2	116,3	3,2	0,17
21	129,1	130,05	31	43,5	3,8	2,7	129,3	3,2	0,2
23	141,1	142	31	43,5	4,6	3,3	141,2	3,2	0,21
25	153,3	154,2	31	43,5	5,4	3,9	153,4	3,2	0,21
27	164,9	166,6	31	43,5	6,4	4,6	165,9	3,2	0,24
29	177,2	179,05	31	43,5	7,5		178,3	3,2	0,25
31	188,6	191,25	31		8,7		190,5	3,2	0,3

Kodierungsbeispiel.

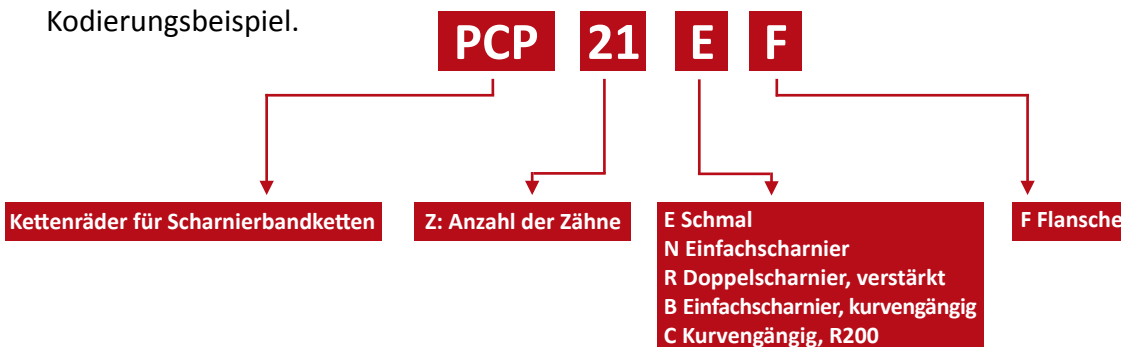

sedis 



A close-up photograph of a metal sprocket. The sprocket has a central hole and a series of teeth around its perimeter. The surface of the sprocket is engraved with the text "5/8 Z=21". The sprocket is set against a red background that is slightly out of focus. The lighting highlights the texture of the metal and the precision of the engraving.

5/8 Z=21

KETTENRÄDER, KETTENRADSCHIEBEN UND GUSSRÄDER

KETTENRÄDER AUS STAHL VORGEBOHRT DIN 03-1 / 04-1

DIN 03-1
B1 = 2,3

DIN 04-1
B1 = 2,6



DIN 03-1
TEILUNG: 5 x 2,5 mm
MATERIAL: C45

DIN 04-1
TEILUNG: 6 x 2,8 mm
MATERIAL: C45

Kettenrad mit einseitiger Nabe für Einfachrollenkettens laut folgenden Normen: DIN 8187 - ISO 606.

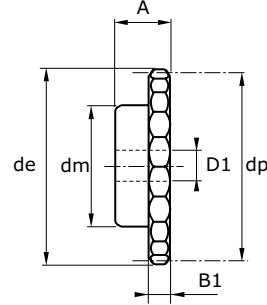

Abmessungen in mm

Z	Art. Nr.	DIN 03-1						DIN 04-1						
		de	dp	dm*	D1*	A*	Kg	Art. Nr.	de	dp	dm*	D1*	A*	Kg
8	P103B008	15,20	13,06	7	4	10	0,01	P104B008	18,00	15,67	9,8	5	10	0,01
9	P103B009	16,80	14,62	8	5	10	0,01	P104B009	19,90	17,54	11,5	5	10	0,01
10	P103B010	18,30	16,18	9	5	10	0,01	P104B010	21,70	19,42	13	6	10	0,01
11	P103B011	19,90	17,75	11	6	10	0,01	P104B011	23,60	21,30	14	6	10	0,01
12	P103B012	21,50	19,32	12	6	10	0,01	P104B012	25,40	23,18	16	6	10	0,02
13	P103B013	23,00	20,89	14	6	10	0,01	P104B013	27,30	25,05	18	8	10	0,02
14	P103B014	24,60	22,47	15	6	10	0,01	P104B014	29,20	26,96	20	8	10	0,03
15	P103B015	26,20	24,04	16	6	10	0,02	P104B015	31,10	28,86	20	8	10	0,03
16	P103B016	27,80	25,63	18	8	13	0,02	P104B016	33,00	30,76	20	8	13	0,03
17	P103B017	29,40	27,20	18	8	13	0,02	P104B017	35,00	32,65	20	8	13	0,04
18	P103B018	30,90	28,79	18	8	13	0,03	P104B018	36,90	34,55	20	8	13	0,04
19	P103B019	22,50	30,38	18	8	13	0,03	P104B019	38,80	36,44	20	8	13	0,04
20	P103B020	34,10	31,96	18	8	13	0,03	P104B020	40,70	38,34	20	8	13	0,04
21	P103B021	35,70	33,54	20	8	13	0,03	P104B021	42,60	40,25	25	8	13	0,06
22	P103B022	37,30	35,13	20	8	13	0,04	P104B022	44,50	42,16	25	8	13	0,06
23	P103B023	38,90	36,72	20	8	13	0,04	P104B023	46,40	44,06	25	8	13	0,06
24	P103B024	40,50	38,30	20	8	13	0,04	P104B024	48,30	45,96	25	8	13	0,07
25	P103B025	42,00	39,89	20	8	13	0,04	P104B025	50,20	47,87	25	8	13	0,07
26	P103B026	43,60	41,48	25	8	15	0,05	P104B026	52,10	49,77	30	8	15	0,10
27	P103B027	45,20	43,07	25	8	15	0,07	P104B027	54,00	51,67	30	8	15	0,10
28	P103B028	46,80	44,65	25	8	15	0,07	P104B028	55,90	53,58	30	8	15	0,11
29	P103B029	48,40	46,25	25	8	15	0,07	P104B029	57,80	55,50	30	8	15	0,11
30	P103B030	50,00	47,83	25	8	15	0,07	P104B030	59,80	57,42	30	8	15	0,11
31	P103B031	51,60	49,42	30	8	15	0,10	P104B031	61,70	59,31	30	8	15	0,11
32	P103B032	53,20	51,01	30	8	15	0,10	P104B032	63,60	61,21	30	8	15	0,12
33	P103B033	54,80	52,60	30	8	15	0,10	P104B033	65,50	63,11	30	8	15	0,12
34	P103B034	56,30	54,19	30	8	15	0,10	P104B034	67,40	65,02	30	8	15	0,12
35	P103B035	57,90	55,78	30	8	15	0,11	P104B035	69,30	66,93	30	8	15	0,13
36	P103B036	59,50	57,37	30	8	15	0,11	P104B036	71,20	68,84	30	8	15	0,13
37	P103B037	61,10	58,96	30	8	15	0,11	P104B037	73,10	70,75	30	8	15	0,14
38	P103B038	62,70	60,54	30	8	15	0,11	P104B038	75,00	72,66	30	8	15	0,14
39	P103B039	64,30	62,13	30	8	15	0,12	P104B039	76,90	74,56	30	8	15	0,14
40	P103B040	65,90	63,73	30	8	15	0,12	P104B040	78,90	76,47	30	8	15	0,15
45	-	-	-	-	-	-	-	P104B045	88,50	86,01	62	10	18	0,46
50	-	-	-	-	-	-	-	P104B050	98,00	95,55	62	12	18	0,49
57	-	-	-	-	-	-	-	P104B057	111,40	108,93	62	12	18	0,53
76	-	-	-	-	-	-	-	P104B076	148,10	145,19	Δ80	16	34	1,58

*Änderungen der Abmessungen vorbehalten, wenden Sie sich bitte im Bedarfsfall an uns
Δ Kettenräder mit angeschweißter Nabe



KETTENRÄDER AUS STAHL VORGEBOHRT DIN 05B

B1	B2	B3	b1
2,8	8,3	-	2,7



Kettenrad mit einseitiger Nabe für Einfach und Zweifachrollenkettens laut folgenden Normen: DIN 8187 - ISO 606.

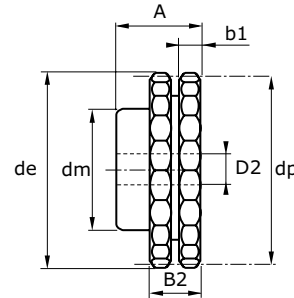
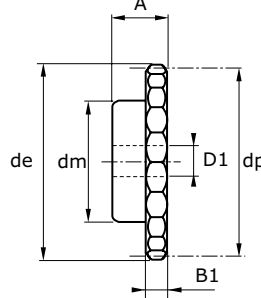

Abmessungen in mm

Z	Art. Nr.	de	dp	EINFACH				DOPPEL			
				dm*	D1*	A*	Kg	dm*	D2*	A*	Kg
8	P..05B008	24,00	20,90	13	6	12	0,01	12	6	18	0,01
9	P..05B009	26,60	23,39	15	6	12	0,02	15	6	18	0,02
10	P..05B010	29,20	25,89	17	8	12	0,02	17	8	18	0,02
11	P..05B011	31,70	28,39	18	8	13	0,03	19	10	18	0,03
12	P..05B012	34,20	30,91	20	8	13	0,04	21	10	18	0,03
13	P..05B013	36,70	33,42	23	8	13	0,05	24	10	18	0,05
14	P..05B014	39,20	35,95	25	8	13	0,05	26	10	18	0,06
15	P..05B015	41,70	38,48	28	8	13	0,07	29	10	18	0,07
16	P..05B016	44,30	41,01	30	8	14	0,08	32	10	20	0,07
17	P..05B017	46,80	43,53	30	8	14	0,09	34	10	20	0,08
18	P..05B018	49,30	46,07	30	8	14	0,09	37	10	20	0,08
19	P..05B019	51,90	48,61	30	8	14	0,09	39	10	20	0,09
20	P..05B020	54,40	51,14	30	8	14	0,10	40	10	20	0,10
21	P..05B021	57,00	53,67	35	8	14	0,12	40	10	20	0,12
22	P..05B022	59,50	56,21	35	8	14	0,13	40	10	20	0,13
23	P..05B023	62,00	58,75	35	8	14	0,13	40	10	20	0,13
24	P..05B024	64,00	61,29	35	8	14	0,14	40	10	20	0,14
25	P..05B025	67,50	63,83	35	8	14	0,15	40	10	20	0,15
26	P..05B026	69,50	66,37	40	10	16	0,19	50	12	22	0,18
27	P..05B027	72,20	68,91	40	10	16	0,20	50	12	22	0,19
28	P..05B028	74,80	71,45	40	10	16	0,20	50	12	22	0,20
29	P..05B029	77,30	73,99	40	10	16	0,21	50	12	22	0,21
30	P..05B030	79,80	76,53	40	10	16	0,22	50	12	22	0,22
31	P..05B031	82,40	79,08	40	10	16	0,22	60	12	22	0,23
32	P..05B032	84,90	81,61	40	10	16	0,22	60	12	22	0,24
33	P..05B033	87,50	84,16	40	10	16	0,23	60	12	22	0,24
34	P..05B034	90,00	86,70	40	10	16	0,24	60	12	22	0,24
35	P..05B035	92,50	89,24	40	10	16	0,25	60	12	22	0,25
36	P..05B036	95,00	91,79	40	10	16	0,25	60	12	22	0,26
37	P..05B037	97,60	94,33	40	10	16	0,26	60	12	22	0,27
38	P..05B038	100,20	96,88	40	10	16	0,27	60	12	22	0,28
39	P..05B039	102,70	99,42	40	10	16	0,28	60	12	22	0,28
40	P..05B040	105,20	101,97	40	10	16	0,29	60	12	22	0,28
45	P..05B045	118,00	114,69	60	12	20	0,58	60	12	22	0,36
50	P..05B050	130,70	127,41	Δ 62	12	20	0,63	60	12	22	0,38
57	P..05B057	148,60	145,22	Δ 80	14	20	1,00	80	14	25	0,40
76	P..05B076	197,70	193,59	Δ 80	20	25	1,94	80	20	25	0,56

*Änderungen der Abmessungen vorbehalten, wenden Sie sich bitte im Bedarfsfall an uns

Δ Kettenräder mit angeschweißter Nabe

.. 1 für einfach; 2 für Zweifach

KETTENRÄDER AUS STAHL VORGEBOHRT 06B

B1
5,3

B2
15,4

B3
25,6

b1
5,1

TEILUNG: 3/8" x 7/32"
TEILUNG: 9,525 x 5,72 mm
MATERIAL: C45

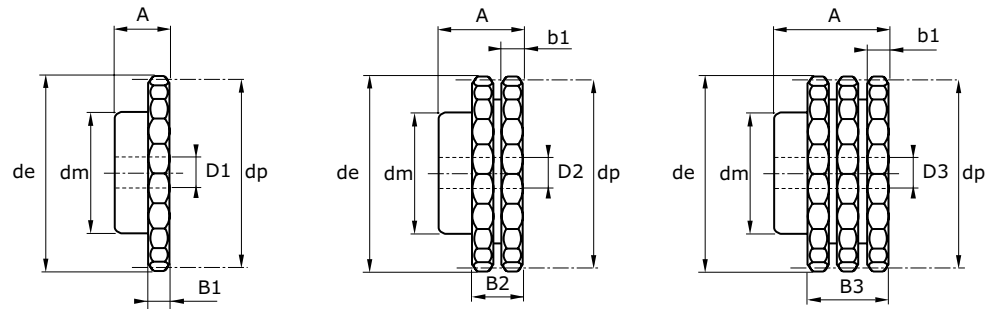

Abmessungen in mm

Z	Art. Nr.	de	dp	EINFACH				ZWEIFACH				DREIFACH			
				dm*	D1*	A*	Kg	dm*	D2*	A*	Kg	dm*	D3*	A*	Kg
8	P..06B008	28,00	24,89	15	8	22	0,03	15	6	22	0,04	15	6	32	0,05
9	P..06B009	31,00	27,85	18	8	22	0,04	18	8	22	0,05	18	8	32	0,07
10	P..06B010	34,00	30,82	20	8	22	0,03	20	8	22	0,06	20	10	32	0,10
11	P..06B011	37,00	33,80	22	8	25	0,06	22	10	25	0,08	22	10	35	0,14
12	P..06B012	40,00	36,80	25	8	25	0,11	25	10	25	0,12	25	10	35	0,18
13	P..06B013	43,00	39,80	28	10	25	0,13	28	10	25	0,14	28	10	35	0,22
14	P..06B014	46,30	42,80	31	10	25	0,17	31	10	25	0,16	31	12	35	0,27
15	P..06B015	49,30	45,81	34	10	25	0,20	34	10	25	0,18	34	12	35	0,32
16	P..06B016	52,30	48,82	37	10	28	0,27	37	12	30	0,22	37	12	35	0,37
17	P..06B017	55,30	51,83	40	10	28	0,31	40	12	30	0,28	40	12	35	0,41
18	P..06B018	58,30	54,85	43	10	28	0,34	43	12	30	0,33	43	12	35	0,45
19	P..06B019	61,30	57,87	45	10	28	0,40	46	12	30	0,37	46	12	35	0,52
20	P..06B020	64,30	60,89	46	10	28	0,41	49	12	30	0,43	49	12	35	0,58
21	P..06B021	68,00	63,91	48	12	28	0,47	52	12	30	0,49	52	14	40	0,69
22	P..06B022	71,00	66,93	50	12	28	0,48	55	12	30	0,55	55	14	40	0,78
23	P..06B023	73,50	69,95	52	12	28	0,54	58	12	30	0,66	58	14	40	0,85
24	P..06B024	77,00	72,97	54	12	28	0,56	61	12	30	0,74	61	14	40	0,95
25	P..06B025	80,00	76,00	57	12	28	0,67	64	12	30	0,81	64	14	40	1,05
26	P..06B026	83,00	79,02	60	12	28	0,68	67	12	30	0,88	67	14	40	1,15
27	P..06B027	86,00	82,04	60	12	28	0,76	70	12	30	0,95	70	14	40	1,25
28	P..06B028	89,00	85,07	60	12	28	0,82	73	12	30	1,05	73	14	40	1,40
29	P..06B029	92,00	88,09	60	12	28	0,93	76	12	30	1,15	76	14	40	1,50
30	P..06B030	94,70	91,12	60	12	30	0,95	79	12	30	1,25	79	14	40	1,60
31	P..06B031	98,30	94,15	65	14	30	1,00	80	16	30	1,35	80	16	40	1,70
32	P..06B032	101,30	97,17	65	14	30	1,02	80	16	30	1,40	80	16	40	1,80
33	P..06B033	104,30	100,20	65	14	30	1,05	80	16	30	1,45	80	16	40	1,90
34	P..06B034	107,30	103,23	65	14	30	1,06	80	16	30	1,55	85	16	40	1,95
35	P..06B035	110,40	106,26	65	14	30	1,10	80	16	30	1,60	85	16	40	2,00
36	P..06B036	113,40	109,29	70	16	30	1,30	90	16	30	1,75	90	16	40	2,25
37	P..06B037	116,40	112,32	70	16	30	1,32	90	16	30	1,85	90	16	40	2,30
38	P..06B038	119,50	115,34	70	16	30	1,35	90	16	30	1,95	90	16	40	2,45
39	P..06B039	122,50	118,37	70	16	30	1,37	90	16	30	2,00	90	16	40	2,55
40	P..06B040	125,50	121,40	70	16	30	1,40	90	16	30	2,15	90	16	40	2,70
45	P..06B045	140,70	136,55	80	16	32	1,70	90	19	40	2,30	90	23	56	3,20
50	P..06B050	155,70	151,69	80	16	32	1,75	90	19	40	3,10	90	23	56	3,50
57	P..06B057	176,90	172,91	80	16	32	1,80	90	19	40	4,60	90	23	56	4,30
65	P..06B065	201,60	197,15	80	20	32	2,05	90	19	40	5,24	90	23	56	4,90
76	P..06B076	234,90	230,49	80	20	32	2,39	100	19	40	5,70	100	23	56	10,00

*Änderungen der Abmessungen vorbehalten, wenden Sie sich bitte im Bedarfsfall an uns .. 1 für einfach; 2 für Zweifach; 3 für dreifach.



KETTENRÄDER AUS STAHL VORGEBOHRT 081 / 083 / 085

DIN 81 B1 = 3 **DIN 083** B1 = 4,5 **DIN 085** B1 = 5,9



081
TEILUNG: 1/2" x 1/8"
TEILUNG: 12,7 x 3,3 mm
MATERIAL: C45

Kettenrad mit einseitiger Nabe für Einfachrollenkettens laut folgenden Normen: DIN 8187 - ISO 606.

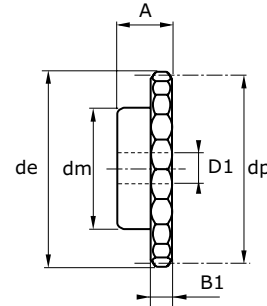

Abmessungen in mm

083
TEILUNG: 1/2" x 3/16"
TEILUNG: 12,7 x 4,88 mm
MATERIAL: C45

085
TEILUNG: 1/2" x 1/4"
TEILUNG: 12,7 x 6,4 x 7,75 mm
MATERIAL: C45

Z	Art. Nr.	EINFACH 081						EINFACH 083						EINFACH 085								
		de	dp	dm*	D1*	A*	Kg	Art. Nr.	de	dp	dm*	D1*	A*	Kg	Z	Art. Nr.	de	dp	dm*	D1*	A*	Kg
8	P1081008	37,20	33,18	21	8	14	0,04	P1083008	38,50	33,18	21	8	14	0,04	8	P1085008	38,5	33,18	20	10	25	0,04
9	P1081009	41,50	37,13	25	8	14	0,05	P1083009	41,50	37,13	25	8	14	0,06	9	P1085009	41,5	37,13	24	10	25	0,06
10	P1081010	46,20	41,10	28	8	14	0,07	P1083010	46,20	41,10	28	8	14	0,08	10	P1085010	46,2	41,10	26	10	25	0,08
11	P1081011	49,60	45,07	31	8	16	0,10	P1083011	49,60	45,07	31	8	16	0,09	11	P1085011	49,6	45,07	29	10	25	0,09
12	P1081012	53,90	49,07	35	8	16	0,11	P1083012	53,90	49,07	35	8	16	0,13	12	P1085012	53,9	49,07	33	10	28	0,13
13	P1081013	58,40	53,06	39	8	16	0,16	P1083013	58,40	53,06	39	8	16	0,16	13	P1085013	58,4	53,06	37	10	28	0,16
14	P1081014	62,80	57,07	43	8	16	0,19	P1083014	62,80	57,07	43	8	16	0,20	14	P1085014	62,8	57,07	41	10	28	0,20
15	P1081015	66,80	61,09	47	8	16	0,21	P1083015	66,80	61,09	47	8	16	0,23	15	P1085015	66,8	61,09	45	10	28	0,23
16	P1081016	70,90	65,10	50	10	18	0,28	P1083016	70,90	65,10	50	10	18	0,30	16	P1085016	70,9	65,10	50	12	28	0,30
17	P1081017	74,90	69,11	50	10	18	0,30	P1083017	74,90	69,11	50	10	18	0,31	17	P1085017	74,9	69,11	52	12	28	0,31
18	P1081018	78,90	73,14	50	10	18	0,31	P1083018	78,90	73,14	50	10	18	0,33	18	P1085018	78,9	73,14	56	12	28	0,33
19	P1081019	82,90	77,16	50	10	18	0,31	P1083019	82,90	77,16	50	10	18	0,34	19	P1085019	82,9	77,16	60	12	28	0,34
20	P1081020	86,90	81,19	50	10	18	0,45	P1083020	86,90	81,19	50	10	18	0,37	20	P1085020	86,9	81,19	64	12	28	0,37
21	P1081021	91,00	85,22	60	12	20	0,48	P1083021	91,00	85,22	60	12	20	0,51	21	P1085021	91,0	85,22	68	14	28	0,51
22	P1081022	95,00	89,24	60	12	20	0,50	P1083022	95,00	89,24	60	12	20	0,53	22	P1085022	95,0	89,24	70	14	28	0,53
23	P1081023	99,00	93,27	60	12	20	0,51	P1083023	99,00	93,27	60	12	20	0,55	23	P1085023	99,0	93,27	70	14	28	0,55
24	P1081024	103,00	97,29	60	12	20	0,52	P1083024	103,00	97,29	60	12	20	0,56	24	P1085024	103,0	97,29	70	14	28	0,56
25	P1081025	107,10	101,33	60	12	20	0,53	P1083025	107,10	101,33	60	12	20	0,58	25	P1085025	107,1	101,33	70	14	28	0,58
26	P1081026	111,20	105,36	70	16	20	0,67	P1083026	111,20	105,36	70	16	20	0,72	28	P1085028	119,4	113,42	70	16	30	0,77
27	P1081027	115,40	109,40	70	16	20	0,68	P1083027	115,40	109,40	70	16	20	0,75	29	P1085029	123,4	117,46	80	16	30	0,79
28	P1081028	119,40	113,42	70	16	20	0,68	P1083028	119,40	113,42	70	16	20	0,77	31	P1085031	131,5	125,54	90	16	30	0,85
29	P1081029	123,40	117,46	70	16	20	0,72	P1083029	123,40	117,46	70	16	20	0,79	32	P1085032	135,5	129,56	90	16	30	0,87
30	P1081030	127,50	121,50	70	16	20	0,75	P1083030	127,50	121,50	70	16	20	0,81	33	P1085033	139,6	133,60	90	16	30	0,89
31	P1081031	131,50	125,54	70	16	20	0,77	P1083031	131,50	125,54	70	16	20	0,85	35	P1085035	147,6	141,68	90	16	30	0,93
32	P1081032	135,50	129,56	70	16	20	0,79	P1083032	135,50	129,56	70	16	20	0,87	37	P1085037	155,7	149,76	90	16	35	0,98
33	P1081033	139,60	133,60	70	16	20	0,81	P1083033	139,60	133,60	70	16	20	0,89	38	P1085038	159,8	153,80	90	16	35	1,15
34	P1081034	143,60	137,67	70	16	20	0,91	P1083034	143,60	137,67	70	16	20	0,91	40	P1085040	167,8	161,87	90	16	35	1,24
35	P1081035	147,60	141,68	70	16	20	0,94	P1083035	145,60	141,68	70	16	20	0,93								
36	P1081036	151,70	145,72	70	16	25	0,96	P1083036	151,70	145,72	70	16	25	0,96								
37	P1081037	155,70	149,76	70	16	25	1,07	P1083037	155,70	149,76	70	16	25	0,98								
38	P1081038	159,80	153,80	70	16	25	1,10	P1083038	159,80	153,80	70	16	25	1,15								
39	P1081039	163,80	157,83	70	16	25	1,13	P1083039	163,80	157,83	70	16	25	1,18								
40	P1081040	167,87	161,87	70	16	25	1,16	P1083040	167,80	161,87	70	16	25	1,24								

*Änderungen der Abmessungen vorbehalten, wenden Sie sich bitte im Bedarfsfall an uns

KETTENRÄDER AUS STAHL/ EDELSTAHL VORGEBOHRT 08B

B1 7,2
B2 21
B3 34,9
b1 7

TEILUNG: 1/2" x 5/16"
TEILUNG: 12,7 x 7,75 mm
MATERIAL: C45
ROSTFREI 304L

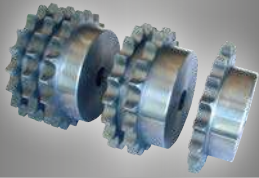

Kettenrad mit einseitiger Nabe für Einfach-, Zweifach- und Dreifachrollenkettens laut folgenden Normen: DIN 8187 - ISO 606.

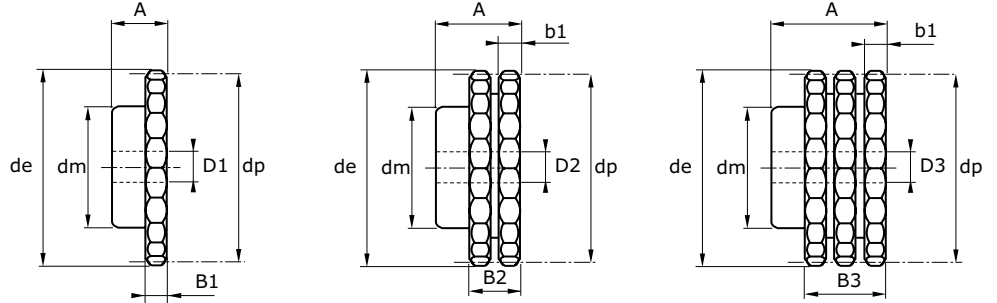

Abmessungen in mm

Z	Art. Nr.	de	dp	EINFACH				ZWEIFACH				DREIFACH			
				dm*	D1*	A*	Kg	dm*	D2*	A*	Kg	dm*	D3*	A*	Kg
8	P.08B008	37,20	33,18	20	10	25	0,07	20	10	32	0,15	20	10	46	0,15
9	P.08B009	41,00	37,13	24	10	25	0,10	24	10	32	0,15	24	12	46	0,19
10	P.08B010	45,20	41,10	26	10	25	0,14	28	10	32	0,19	28	12	46	0,26
11	P.08B011	48,70	45,07	29	10	25	0,16	32	12	35	0,27	32	14	50	0,30
12	P.08B012	53,00	49,07	33	10	28	0,22	35	12	35	0,32	35	14	50	0,38
13	P.08B013	57,40	53,06	37	10	28	0,28	38	12	35	0,37	38	14	50	0,59
14	P.08B014	61,80	57,07	41	10	28	0,33	42	12	35	0,44	42	14	50	0,71
15	P.08B015	65,50	61,09	45	10	28	0,40	46	12	35	0,50	46	16	50	0,82
16	P.08B016	69,50	65,10	50	12	28	0,48	50	14	35	0,62	50	16	50	0,96
17	P.08B017	73,60	69,11	52	12	28	0,55	54	14	35	0,72	54	16	50	1,05
18	P.08B018	77,80	73,14	56	12	28	0,60	58	14	35	0,86	58	16	50	1,25
19	P.08B019	81,70	77,16	60	12	28	0,69	62	14	35	0,93	62	16	50	1,35
20	P.08B020	86,80	81,19	64	12	28	0,77	66	14	35	1,05	66	16	50	1,50
21	P.08B021	89,70	85,22	68	14	28	0,88	70	16	40	1,15	70	20	55	1,70
22	P.08B022	93,80	89,24	70	14	28	0,93	70	16	40	1,40	70	20	55	2,00
23	P.08B023	98,20	93,27	70	14	28	0,95	70	16	40	1,60	70	20	55	2,25
24	P.08B024	101,80	97,29	70	14	28	1,00	75	16	40	1,70	75	20	55	2,40
25	P.08B025	105,80	101,33	70	14	28	1,05	80	16	40	1,95	80	20	55	2,57
26	P.08B026	110,00	105,36	70	16	30	1,10	85	16	40	2,10	85	20	55	2,95
27	P.08B027	114,00	109,40	70	16	30	1,15	85	16	40	2,20	85	20	55	3,15
28	P.08B028	118,00	113,42	70	16	30	1,20	90	16	40	2,40	90	20	55	3,40
29	P.08B029	120,00	117,76	80	16	30	1,40	95	16	40	2,60	95	20	55	3,75
30	P.08B030	126,40	121,50	80	16	30	1,50	100	16	40	2,80	100	20	55	4,00
31	P.08B031	130,20	125,54	90	16	30	1,70	100	20	40	3,20	110	20	55	4,55
32	P.08B032	134,30	129,56	90	16	30	1,75	100	20	40	3,35	110	20	55	4,75
33	P.08B033	138,60	133,60	90	16	30	1,80	100	20	40	3,50	110	20	55	4,95
34	P.08B034	142,70	137,64	90	16	30	1,85	100	20	40	3,60	110	20	55	5,15
35	P.08B035	146,00	141,68	90	16	30	1,90	100	20	40	3,75	110	20	55	5,40
36	P.08B036	151,00	145,72	90	16	35	2,25	110	20	40	4,10	120	25	55	5,95
37	P.08B037	154,60	149,76	90	16	35	2,30	110	20	40	1,25	120	25	55	6,15
38	P.08B038	158,60	153,80	90	16	35	2,35	110	20	40	4,45	120	25	55	6,35
39	P.08B039	162,70	157,83	90	16	35	2,40	110	20	40	4,60	120	25	55	6,65
40	P.08B040	166,70	161,87	90	16	35	2,45	110	20	40	4,75	120	25	55	7,00
45	P.08B045	188,00	182,07	Δ 88	20	42	3,20	Δ 108	20	55	6,20	Δ 120	25	68	9,30
50	P.08B050	208,30	202,26	Δ 88	20	42	3,50	Δ 108	20	55	6,90	Δ 120	25	68	10,40
57	P.08B057	236,40	230,54	Δ 90	20	40	4,00	Δ 100	25	40	9,00	Δ 120	25	60	13,50
65	P.08B065	269,00	262,86	Δ 90	25	40	5,50	Δ 100	25	40	10,26	Δ 120	25	60	15,78
76	P.08B076	313,30	307,33	Δ 90	25	40	6,40	Δ 100	25	55	14,50	Δ 120	25	60	23,00

*Änderungen der Abmessungen vorbehalten, wenden Sie sich bitte im Bedarfsfall an uns

Δ Kettenräder mit angeschweißter Nabe

.. 1 für einfach; 2 für zweifach; 3 für dreifach.



KETTENRÄDER AUS STAHL/ EDELSTAHL VORGEBOHRT 10B

B1	B2	B3	b1
9,1	25,5	42,1	9

TEILUNG: 5/8" x 3/8"
TEILUNG: 15,875 x 9,65 mm
MATERIAL: C45
ROSTFREI 304L

Kettenrad mit einseitiger Nabe für Einfach-, Zweifach- und Dreifachrollenkettens laut folgenden Normen: DIN 8187 - ISO 606.

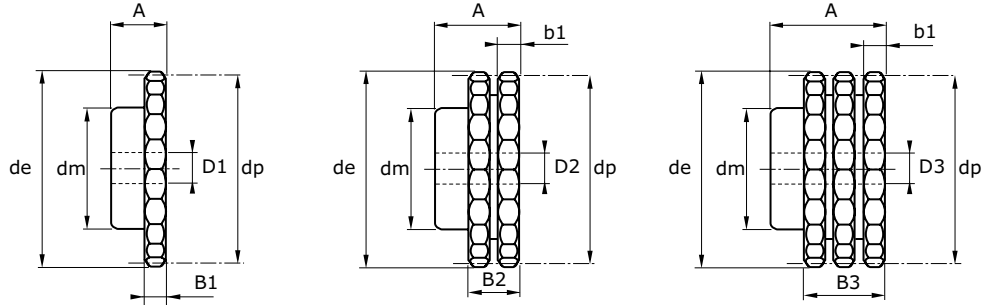

Abmessungen in mm

Z	Art. Nr.	de	dp	EINFACH				ZWEIFACH				DREIFACH			
				dm*	D1*	A*	Kg	dm*	D2*	A*	Kg	dm*	D3*	A*	Kg
8	P..10B008	48,00	41,48	25	10	25	0,13	25	12	40	0,20	25	12	55	0,25
9	P..10B009	52,60	46,42	30	10	25	0,18	30	12	40	0,27	30	12	55	0,35
10	P..10B010	57,50	51,37	35	10	25	0,24	35	12	40	0,33	35	16	55	0,46
11	P..10B011	63,00	56,34	37	12	30	0,32	39	14	40	0,44	39	16	55	0,57
12	P..10B012	68,00	61,34	42	12	30	0,40	44	14	40	0,58	44	16	55	0,73
13	P..10B013	73,00	66,32	47	12	30	0,48	49	14	40	0,72	49	16	55	0,98
14	P..10B014	78,00	71,34	52	12	30	0,59	54	16	40	0,87	54	16	55	1,20
15	P..10B015	83,00	76,36	57	12	30	0,68	59	14	40	0,99	59	16	55	1,35
16	P..10B016	88,00	81,37	60	12	30	0,76	64	16	45	1,30	64	16	60	1,55
17	P..10B017	93,00	86,39	60	12	30	0,81	69	16	45	1,45	69	16	60	1,80
18	P..10B018	98,30	91,42	70	14	30	0,90	74	16	45	1,70	74	16	60	2,40
19	P..10B019	103,30	96,45	70	14	30	1,05	79	16	45	1,85	79	16	60	2,45
20	P..10B020	108,40	101,49	75	14	30	1,20	84	16	45	2,20	84	16	60	2,90
21	P..10B021	113,40	106,52	75	16	30	1,25	85	16	45	2,35	85	20	60	2,95
22	P..10B022	118,00	111,55	80	16	30	1,40	90	16	45	2,60	90	20	60	3,55
23	P..10B023	123,50	116,58	80	16	30	1,45	95	16	45	2,90	95	20	60	3,95
24	P..10B024	128,30	121,62	80	16	30	1,50	100	16	45	3,20	100	20	60	4,35
25	P..10B025	134,00	126,66	80	16	30	1,60	105	16	45	3,45	105	20	60	4,65
26	P..10B026	139,00	131,70	85	20	35	1,85	110	20	45	3,85	110	20	60	5,05
27	P..10B027	144,00	136,75	85	20	35	1,95	110	20	45	4,00	110	20	60	5,40
28	P..10B028	148,70	141,78	90	20	35	2,30	115	20	45	4,35	115	20	60	5,95
29	P..10B029	153,80	146,83	90	20	35	2,35	115	20	45	4,40	115	20	60	6,25
30	P..10B030	158,80	151,87	90	20	35	2,45	120	20	45	4,95	120	20	60	6,70
31	P..10B031	163,80	156,92	95	20	35	2,65	120	20	45	5,25	120	20	60	7,10
32	P..10B032	168,90	161,95	95	20	35	2,70	120	20	45	5,50	120	20	60	7,50
33	P..10B033	174,50	167,00	95	20	35	2,80	120	20	45	5,80	120	20	60	7,85
34	P..10B034	179,00	172,05	95	20	35	2,85	120	20	45	6,05	120	20	60	8,35
35	P..10B035	184,10	177,10	95	20	35	2,90	120	20	45	6,30	120	20	60	8,65
36	P..10B036	189,10	182,15	100	20	35	3,30	120	20	45	6,55	120	25	60	9,15
37	P..10B037	194,20	187,20	100	20	35	3,40	120	20	45	6,80	120	25	60	9,65
38	P..10B038	199,20	192,24	100	20	35	3,50	120	20	45	7,03	120	25	60	10,20
39	P..10B039	204,20	197,29	100	20	35	3,60	120	20	45	7,25	120	25	60	10,70
40	P..10B040	209,30	202,34	100	20	35	3,70	120	20	45	7,55	120	25	60	11,10
45	P..10B045	235,00	227,58	Δ 100	20	40	6,00	Δ 120	25	45	8,50	Δ 130	25	60	12,48
50	P..10B050	260,30	252,82	Δ 100	20	40	6,70	Δ 120	25	45	9,43	Δ 130	25	60	13,87
57	P..10B057	296,00	288,18	Δ 100	25	40	7,50	Δ 120	25	45	10,90	Δ 130	25	60	15,81
65	P..10B065	336,50	328,58	Δ 100	25	50	8,55	Δ 120	25	45	12,43	Δ 130	30	67	18,03
76	P..10B076	492,10	384,16	Δ 100	25	50	9,99	Δ 130	25	63	15,90	Δ 130	30	67	21,09

*Änderungen der Abmessungen vorbehalten, wenden Sie sich bitte im Bedarfsfall an uns

Δ Kettenräder mit angeschweißter Nabe

.. 1 für einfach; 2 für zweifach; 3 für dreifach.

KETTENRÄDER AUS STAHL/ EDELSTAHL VORGEBOHRT 12B

B1	B2	B3	b1
11,1	30,3	49,8	10,8

TEILUNG: 3/4" x 7/16"
 TEILUNG: 19,05 x 11,68 mm
 MATERIAL: C45
 ROSTFREI 304L



Kettenrad mit einseitiger Nabe für Einfach-, Zweifach- und Dreifachrollenkettens laut folgenden Normen: DIN 8187 - ISO 606.

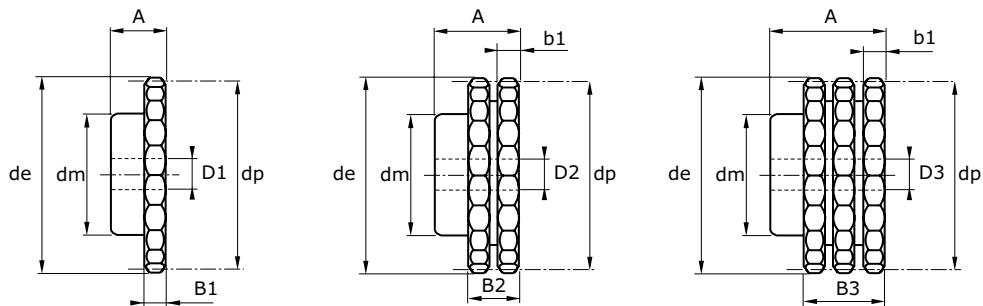

Abmessungen in mm

Z	Art. Nr.	de	dp	EINFACH				ZWEIFACH				DREIFACH			
				dm*	D1*	A*	Kg	dm*	D2*	A*	Kg	dm*	D3*	A*	Kg
8	P..12B008	57,60	49,78	31	12	30	0,20	31	12	45	0,30	31	16	65	0,40
9	P..12B009	62,00	55,70	37	12	30	0,35	37	12	45	0,45	37	16	65	0,68
10	P..12B010	69,00	61,64	42	12	30	0,40	42	12	45	0,64	42	16	65	0,91
11	P..12B011	75,00	67,61	46	14	35	0,57	47	16	50	0,89	47	20	70	1,20
12	P..12B012	81,50	73,60	52	14	35	0,70	53	16	50	1,10	53	20	70	1,65
13	P..12B013	87,50	79,59	58	14	35	0,80	59	16	50	1,30	59	20	70	1,90
14	P..12B014	93,60	85,61	64	14	35	1,00	65	16	50	1,60	65	20	70	2,25
15	P..12B015	99,80	91,63	70	14	35	1,10	71	16	50	1,80	71	20	70	2,60
16	P..12B016	105,50	97,65	75	16	35	1,35	77	20	50	2,15	77	20	70	3,05
17	P..12B017	111,90	103,67	80	16	35	1,45	83	20	50	2,55	83	20	70	3,50
18	P..12B018	118,00	109,71	80	16	35	1,55	89	20	50	3,10	89	20	70	4,10
19	P..12B019	124,20	115,75	80	16	35	1,65	95	20	50	3,35	95	20	70	4,50
20	P..12B020	129,70	121,78	80	16	35	1,75	100	20	50	3,85	100	20	70	4,90
21	P..12B021	136,00	127,82	90	20	40	1,95	100	20	50	4,05	100	20	70	5,50
22	P..12B022	141,80	133,86	90	20	40	2,45	100	20	50	4,30	100	20	70	5,95
23	P..12B023	149,00	139,90	90	20	40	2,60	110	20	50	4,80	110	20	70	6,75
24	P..12B024	153,90	145,94	90	20	40	2,65	110	20	50	5,00	110	20	70	7,10
25	P..12B025	160,00	152,00	90	20	40	2,80	120	20	50	5,55	120	20	70	7,95
26	P..12B026	165,90	158,04	95	20	40	3,15	120	20	50	5,90	120	20	70	8,50
27	P..12B027	172,30	164,09	95	20	40	3,20	120	20	50	6,20	120	20	70	9,00
28	P..12B028	178,00	170,13	95	20	40	3,35	120	20	50	6,55	120	20	70	9,60
29	P..12B029	184,10	176,19	95	20	40	3,55	120	20	50	6,90	120	20	70	10,20
30	P..12B030	190,50	182,25	95	20	40	3,70	120	20	50	7,20	120	20	70	10,70
31	P..12B031	196,30	188,31	100	20	40	3,80	120	20	50	7,80	130	25	70	11,70
32	P..12B032	202,30	194,35	100	20	40	3,90	120	20	50	8,25	130	25	70	12,30
33	P..12B033	209,30	200,40	100	20	40	4,10	120	20	50	8,65	130	25	70	13,10
34	P..12B034	214,60	206,46	100	20	40	4,20	120	20	50	9,10	130	25	70	13,90
35	P..12B035	221,00	212,52	100	20	40	4,35	120	20	50	9,45	130	25	70	14,40
36	P..12B036	226,80	218,58	100	20	40	4,70	120	25	50	9,90	130	25	70	15,30
37	P..12B037	232,90	224,64	100	20	40	5,10	120	25	50	10,40	130	25	70	16,10
38	P..12B038	239,00	230,69	100	20	40	5,20	120	25	50	10,80	130	25	70	16,90
39	P..12B039	245,10	236,75	100	20	40	5,25	120	25	50	11,40	130	25	70	17,90
40	P..12B040	251,30	242,81	100	20	40	5,40	Δ 120	25	50	11,90	130	25	70	18,60
45	P..12B045	282,50	273,10	Δ 100	25	40	5,00	Δ 120	25	50	13,40	140	25	70	23,20
50	P..12B050	312,30	303,39	Δ 100	25	40	5,80	Δ 120	25	50	14,30	140	25	70	28,50
57	P..12B057	355,40	345,81	Δ 100	25	40	6,65	Δ 120	25	50	15,80	Δ 140	30	70	37,50
65	P..12B065	403,20	394,21	Δ 100	25	40	8,50	Δ 120	30	50	16,50	Δ 140	30	70	50,00
76	P..12B076	469,90	460,99	Δ 110	25	56	10,00	Δ 140	30	63	17,00	Δ 140	30	70	62,50

*Änderungen der Abmessungen vorbehalten, wenden Sie sich bitte im Bedarfsfall an uns

Δ Kettenräder mit angeschweißter Nabe

.. 1 für einfach; 2 für zweifach; 3 für dreifach.



KETTENRÄDER AUS STAHL/ EDELSTAHL VORGEBOHRT 16B

B1	B2	B3	b1
16,2	47,7	79,6	15,8

TEILUNG: 1" x 17,02 mm
 TEILUNG: 25,4 x 17,02 mm
 MATERIAL: C45
 ROSTFREI 304L

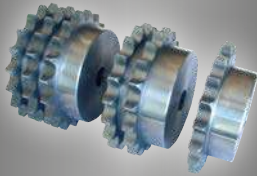

Kettenrad mit einseitiger Nabe für Einfach-, Zweifach- und Dreifachrollenkettens laut folgenden Normen: DIN 8187 - ISO 606.

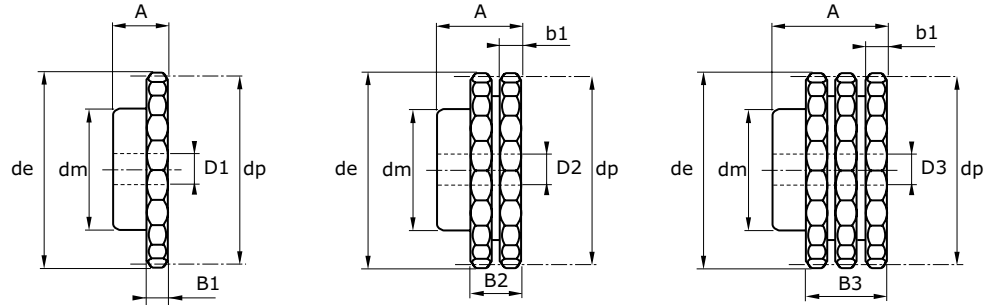

Abmessungen in mm

Z	Art. Nr.	de	dp	EINFACH				ZWEIFACH				DREIFACH			
				dm*	D1*	A*	Kg	dm*	D2*	A*	Kg	dm*	D3*	A*	Kg
8	P..16B008	77,00	66,37	42	16	35	0,50	42	16	65	0,60	42	20	95	1,32
9	P..16B009	85,00	74,27	50	16	35	0,70	50	16	65	1,20	50	20	95	1,83
10	P..16B010	93,00	82,19	55	16	35	0,85	56	16	65	1,70	56	20	95	2,35
11	P..16B011	99,50	90,14	61	16	40	1,10	64	20	70	2,15	64	25	100	2,80
12	P..16B012	109,00	98,14	69	16	40	1,45	72	20	70	2,65	72	25	100	3,70
13	P..16B013	117,00	106,12	78	16	40	1,75	80	20	70	3,40	80	25	100	2,42
14	P..16B014	125,00	114,15	84	16	40	2,05	88	20	70	3,95	88	25	100	5,42
15	P..16B015	133,00	122,17	92	16	40	2,25	96	20	70	4,45	96	25	100	7,00
16	P..16B016	141,0	130,20	100	20	45	2,90	104	20	70	5,25	104	25	100	8,00
17	P..16B017	149,00	138,22	100	20	45	3,05	112	20	70	5,85	112	25	100	8,54
18	P..16B018	157,00	146,28	100	20	45	3,50	120	20	70	7,00	120	25	100	9,70
19	P..16B019	165,20	154,33	100	20	45	3,60	128	20	70	7,70	128	25	100	10,87
20	P..16B020	173,20	162,38	100	20	45	3,80	130	20	70	8,90	130	25	100	12,25
21	P..16B021	181,20	170,43	110	20	50	4,30	130	25	70	9,75	130	25	100	13,40
22	P..16B022	189,30	178,48	110	20	50	4,55	130	25	70	10,30	130	25	100	14,00
23	P..16B023	197,50	186,53	110	20	50	4,90	130	25	70	11,20	130	25	100	16,00
24	P..16B024	205,50	194,59	110	20	50	5,05	130	25	70	12,00	130	25	100	17,18
25	P..16B025	213,50	202,66	110	20	50	5,25	130	25	70	12,70	130	25	100	18,70
26	P..16B026	221,60	210,72	120	20	50	6,40	130	25	70	13,80	130	30	100	20,37
27	P..16B027	229,60	218,79	120	20	50	6,65	130	25	70	14,50	130	30	100	21,87
28	P..16B028	237,70	226,85	120	20	50	6,95	130	25	70	15,60	130	30	100	23,65
29	P..16B029	245,80	234,92	120	20	50	7,40	130	25	70	16,40	130	30	100	25,36
30	P..16B030	254,00	243,00	120	20	50	7,65	130	25	70	17,40	130	30	100	27,04
31	P..16B031	262,00	251,08	120	25	50	8,00	140	25	70	18,60	140	30	100	29,10
32	P..16B032	270,00	259,13	120	25	50	8,40	140	25	70	19,60	140	30	100	31,10
33	P..16B033	278,50	267,21	120	25	50	8,75	140	25	70	20,90	140	30	100	33,10
34	P..16B034	287,00	275,28	120	25	50	9,25	140	25	70	22,00	140	30	100	35,00
35	P..16B035	296,20	283,36	120	25	50	9,60	140	25	70	23,10	140	30	100	36,66
36	P..16B036	304,60	291,44	120	25	50	9,95	140	25	70	24,70	140	30	100	39,64
37	P..16B037	312,60	299,51	120	25	50	10,30	140	25	70	25,80	140	30	100	40,80
38	P..16B038	320,70	307,59	120	25	50	10,70	140	25	70	27,20	140	30	100	42,50
39	P..16B039	328,80	315,67	120	25	50	11,30	140	25	70	28,40	140	30	100	43,00
40	P..16B040	336,90	323,73	120	25	50	11,90	140	25	70	29,90	140	30	100	44,50
45	P..16B045	377,10	364,12	Δ 125	25	70	13,38	Δ 150	25	80	33,63	Δ 150	30	100	-
50	P..16B050	417,40	404,52	Δ 125	25	70	14,87	Δ 150	30	80	37,37	Δ 150	30	100	-
57	P..16B057	474,00	461,07	Δ 125	30	70	16,95	Δ 160	30	90	42,60	Δ 160	40	110	-
76	P..16B076	627,00	614,65	Δ 140	30	80	22,61	Δ 160	30	90	56,81	Δ 160	40	110	-

*Änderungen der Abmessungen vorbehalten, wenden Sie sich bitte im Bedarfsfall an uns
 Δ Kettenräder mit angeschweißter Nabe
 .. 1 für einfach; 2 für zweifach; 3 für dreifach.

KETTENRÄDER AUS STAHL/ EDELSTAHL VORGEBOHRT 20B

B1
18,5

B2
54,6

B3
91

b1
18,2

TEILUNG: 1"1/4 x 3/4"
TEILUNG: 31,75 x 19,56 mm
MATERIAL: C45
ROSTFREI 304L

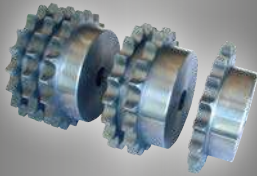

Kettenrad mit einseitiger Nabe für Einfach-, Zweifach- und Dreifachrollenkettens laut folgenden Normen: DIN 8187 - ISO 606.

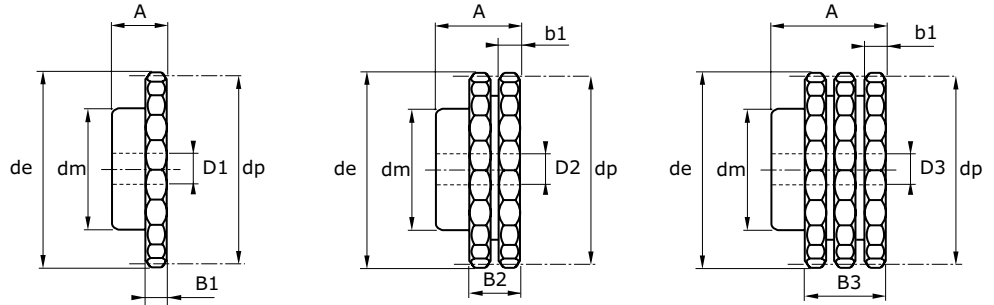

Abmessungen in mm

Z	Art. Nr.	de	dp	EINFACH				ZWEIFACH				DREIFACH			
				dm*	D1*	A*	Kg	dm*	D2*	A*	Kg	dm*	D3*	A*	Kg
8	P..20B008	98,10	82,96	53	20	40	0,90	53	20	75	1,75	53	25	110	2,05
9	P..20B009	108,00	92,84	63	20	40	1,25	63	20	75	2,75	63	25	110	3,05
10	P..20B010	117,90	102,74	70	20	40	1,75	70	20	75	3,60	70	25	110	4,04
11	P..20B011	127,80	112,68	77	20	45	2,25	80	25	80	4,75	80	30	115	5,19
12	P..20B012	137,80	122,68	88	20	45	2,75	90	25	80	5,70	90	30	115	6,55
13	P..20B013	147,80	132,65	98	20	45	3,30	100	25	80	6,75	100	30	115	8,06
14	P..20B014	157,80	142,68	108	20	45	4,10	110	25	80	8,00	110	30	115	9,71
15	P..20B015	167,90	152,72	118	20	45	5,25	120	25	80	10,00	120	30	115	11,50
16	P..20B016	177,90	162,75	120	25	50	5,50	120	30	80	11,20	120	30	115	13,06
17	P..20B017	187,90	172,78	120	25	50	5,80	120	30	80	12,20	120	30	115	14,65
18	P..20B018	198,00	182,85	120	25	50	6,20	120	30	80	13,50	120	30	115	16,54
19	P..20B019	208,10	192,91	120	25	50	6,50	120	30	80	14,50	120	30	115	18,45
20	P..20B020	218,10	202,98	120	25	50	7,00	120	30	80	15,80	120	30	115	20,48
21	P..20B021	228,20	213,04	140	25	55	9,00	140	30	80	17,20	140	30	115	23,38
22	P..20B022	238,30	223,11	140	25	55	9,50	140	30	80	18,50	140	30	115	25,64
23	P..20B023	248,30	233,17	140	25	55	10,00	140	30	80	20,00	140	30	115	28,00
24	P..20B024	258,40	243,23	140	25	55	10,50	140	30	80	21,50	140	30	115	30,49
25	P..20B025	268,50	253,33	140	25	55	11,60	140	30	80	24,00	140	30	115	33,09
26	P..20B026	278,60	263,40	150	30	55	12,10	150	30	80	27,00	150	30	115	36,23
27	P..20B027	288,60	273,48	150	30	55	12,80	150	30	80	28,50	150	30	115	39,06
28	P..20B028	298,70	283,56	150	30	55	13,40	150	30	80	30,50	150	30	115	42,00
29	P..20B029	308,80	293,65	150	30	55	14,10	150	30	80	32,20	150	30	115	45,12
30	P..20B030	318,90	303,75	150	30	55	14,50	150	30	80	34,00	150	30	115	48,23
31	P..20B031	329,00	313,85	Δ 160	30	55	15,20	Δ 150	30	80	36,00	150	30	115	51,57
32	P..20B032	339,10	323,91	Δ 160	30	55	16,10	Δ 150	30	80	38,50	Δ 150	30	115	54,91
33	P..20B033	349,20	334,01	Δ 160	30	55	16,80	Δ 150	30	80	40,70	Δ 150	30	115	58,49
34	P..20B034	359,30	344,10	Δ 160	30	55	17,50	Δ 150	30	80	43,10	Δ 150	30	115	62,06
35	P..20B035	369,20	354,20	Δ 160	30	55	18,50	Δ 150	30	80	45,00	Δ 150	30	115	65,80
36	P..20B036	379,50	364,30	Δ 160	30	55	19,00	Δ 150	30	80	47,50	Δ 150	30	115	69,66
37	P..20B037	389,50	374,39	Δ 160	30	55	20,00	Δ 150	30	80	50,00	Δ 150	30	115	73,69
38	P..20B038	399,40	384,49	Δ 160	30	55	20,50	Δ 150	30	80	53,50	Δ 150	30	115	77,72
39	P..20B039	409,70	394,59	Δ 160	30	55	21,50	Δ 150	30	80	55,00	Δ 150	30	115	81,98
40	P..20B040	419,80	404,66	Δ 160	30	55	22,50	Δ 150	30	80	57,50	Δ 150	30	115	86,24
45	P..20B045	470,30	455,17	Δ 150	30	70	25,31	Δ 160	30	90	64,68	Δ 180	40	115	110,41
50	P..20B050	520,80	505,65	Δ 150	30	70	28,12	Δ 160	30	90	71,87	Δ 180	40	125	136,59
57	P..20B057	591,50	576,36	Δ 150	30	80	32,05	Δ 160	30	100	81,93	Δ 180	40	125	181,21
76	P..20B076	783,50	768,32	Δ 150	30	90	42,74	Δ 160	30	180	98,00	Δ 200	40	140	322,03

*Änderungen der Abmessungen vorbehalten, wenden Sie sich bitte im Bedarfsfall an uns

Δ Kettenräder mit angeschweißter Nabe

.. 1 für einfach; 2 für zweifach; 3 für dreifach.



KETTENRÄDER AUS STAHL/ EDELSTAHL VORGEBOHRT 24B

B1	B2	B3	b1
24,1	72	120,3	23,6

TEILUNG: 1"1/2 x 1"
 TEILUNG: 38,10 x 25,4 mm
 MATERIAL: C45
 ROSTFREI 304L

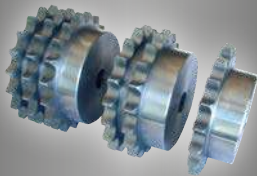

Kettenrad mit einseitiger Nabe für Einfach-, Zweifach- und Dreifachrollenkettens laut folgenden Normen: DIN 8187 - ISO 606.

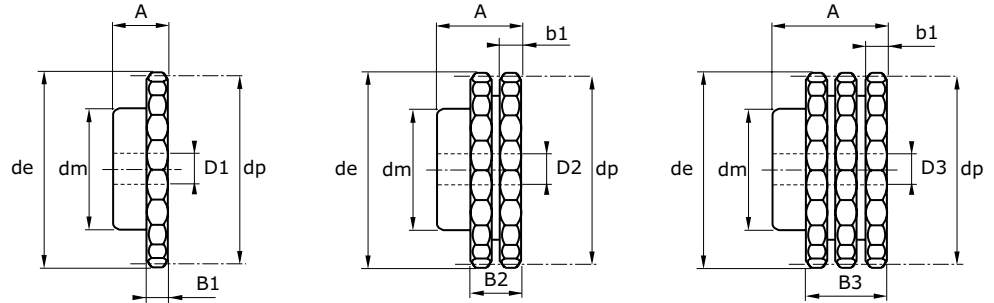

Abmessungen in mm

Z	Art. Nr.	de	dp	EINFACH				ZWEIFACH				DREIFACH			
				dm*	D1*	A*	Kg	dm*	D2*	A*	Kg	dm*	D3*	A*	Kg
8	P..24B008	115,00	99,55	58	20	45	1,60	58	25	95	2,90	58	25	140	4,00
9	P..24B009	126,40	111,40	70	20	45	1,95	70	25	95	4,00	70	25	140	5,62
10	P..24B010	138,00	123,29	80	20	45	2,40	80	25	95	5,10	80	25	140	7,45
11	P..24B011	150,00	135,25	90	25	50	3,40	90	25	100	6,70	90	30	150	9,73
12	P..24B012	162,00	147,22	102	25	50	4,10	102	25	100	8,40	102	30	150	12,24
13	P..24B013	174,20	159,18	114	25	50	4,70	114	25	100	10,20	114	30	150	15,02
14	P..24B014	186,20	171,22	128	25	50	6,10	128	25	100	12,30	128	30	150	18,16
15	P..24B015	198,20	183,26	140	25	50	7,00	140	25	100	14,30	140	30	150	21,09
16	P..24B016	210,30	195,30	140	25	55	8,30	140	30	100	16,80	140	30	150	24,25
17	P..24B017	222,30	207,34	136	25	55	8,90	136	30	100	18,80	136	30	150	27,42
18	P..24B018	234,30	219,42	140	25	55	9,70	160	30	100	21,00	160	30	150	32,12
19	P..24B019	246,50	231,49	140	25	55	10,40	160	30	100	23,00	160	30	150	35,74
20	P..24B020	258,50	243,57	140	25	55	11,20	160	30	100	25,50	160	30	150	39,57
21	P..24B021	270,50	255,65	150	30	60	13,30	160	30	100	28,00	160	40	150	42,98
22	P..24B022	282,70	267,73	150	30	60	14,20	160	30	100	30,50	160	40	150	47,25
23	P..24B023	294,80	279,80	150	30	60	15,20	160	30	100	33,00	160	40	150	51,74
24	P..24B024	306,80	291,88	150	30	60	16,10	160	30	100	35,00	160	40	150	56,44
25	P..24B025	319,00	304,00	150	30	60	17,00	160	30	100	37,50	160	40	150	61,37
26	P..24B026	331,00	316,08	Δ 160	30	60	18,60	Δ 160	30	100	41,00	Δ 160	40	150	66,52
27	P..24B027	343,20	328,19	Δ 160	30	60	19,70	Δ 160	30	100	44,50	Δ 160	40	150	71,88
28	P..24B028	355,20	340,27	Δ 160	30	60	20,70	Δ 160	30	100	47,50	Δ 160	40	150	77,46
29	P..24B029	367,30	352,38	Δ 160	30	60	21,90	Δ 160	30	100	51,00	Δ 160	40	150	83,37
30	P..24B030	379,50	364,50	Δ 160	30	60	23,00	Δ 160	30	100	54,00	Δ 160	40	150	89,28
31	P..24B031	391,60	376,62	Δ 160	30	60	24,50	Δ 160	40	100	58,00	Δ 160	40	150	95,63
32	P..24B032	403,70	388,69	Δ 160	30	60	25,80	Δ 160	40	100	62,00	Δ 160	40	150	101,97
33	P..24B033	415,80	400,81	Δ 160	30	60	27,00	Δ 160	40	100	66,00	Δ 160	40	150	107,14
34	P..24B034	427,80	412,83	Δ 160	30	60	28,50	Δ 160	40	100	70,00	Δ 160	40	150	112,31
35	P..24B035	440,00	425,04	Δ 160	30	60	30,00	Δ 160	40	100	74,00	Δ 160	40	150	122,64
36	P..24B036	452,00	437,16	Δ 160	30	60	31,50	Δ 160	40	100	78,00	Δ 160	40	150	128,30
37	P..24B037	464,20	449,27	Δ 160	30	60	32,50	Δ 160	40	100	83,00	Δ 160	40	150	133,96
38	P..24B038	476,20	461,39	Δ 160	30	60	34,00	Δ 160	40	100	87,00	Δ 160	40	150	145,28
39	P..24B039	488,50	473,54	Δ 160	30	60	35,50	Δ 170	30	100	92,00	Δ 160	40	150	153,37
40	P..24B040	500,60	485,62	Δ 160	30	60	37,00	Δ 170	40	100	96,00	Δ 160	40	150	161,46
45	P..24B045	562,00	546,20	Δ 160	30	99	41,65	Δ 180	40	133	108,00	Δ 170	40	150	209,06
50	P..24B050	622,50	606,78	Δ 160	30	99	46,25	Δ 180	40	133	120,00	Δ 170	40	150	258,81
57	P..24B057	707,50	691,63	Δ 168	30	99	48,00	Δ 200	40	133	136,80	Δ 170	40	150	337,62
76	P..24B076	939,00	921,98	Δ 170	40	118	59,50	Δ 220	40	133	166,00	Δ 200	40	150	607,76

*Änderungen der Abmessungen vorbehalten, wenden Sie sich bitte im Bedarfsfall an uns
 Δ Kettenräder mit angeschweißter Nabe
 .. 1 für einfach; 2 für zweifach; 3 für dreifach.

KETTENRÄDER AUS STAHL/ EDELSTAHL VORGEBOHRT 28B

B1	B2	B3	b1
29,4	88,4	148	28,8

TEILUNG: 1"3/4 x 1"1/4"
 TEILUNG: 44,45 x 30,99 mm
 MATERIAL: C45
 ROSTFREI 304L

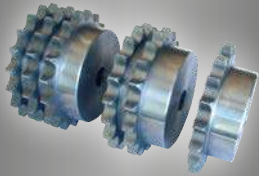

Kettenrad mit einseitiger Nabe für Einfach-, Zweifach- und Dreifachrollenkettens laut folgenden Normen: DIN 8187 - ISO 606.

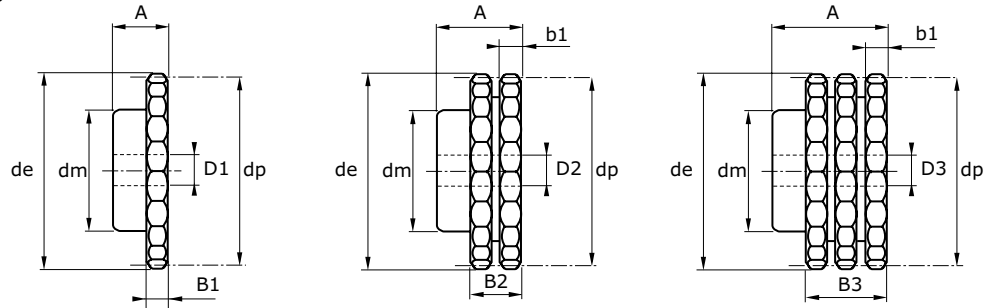

Abmessungen in mm

Z	Art. Nr.	de	dp	EINFACH				ZWEIFACH				DREIFACH			
				dm*	D1*	A*	Kg	dm*	D2*	A*	Kg	dm*	D3*	A*	Kg
8	P..28B008	132,00	116,15	74	25	70	3,10	74	25	120	5,50	74	30	180	7,04
9	P..28B009	148,40	129,96	88	25	70	4,20	88	25	120	7,20	88	30	180	9,89
10	P..28B010	162,30	143,85	100	25	70	5,40	100	25	120	9,50	100	30	180	13,10
11	P..28B011	176,30	157,77	112	25	70	6,60	112	25	120	11,50	112	30	180	16,73
12	P..28B012	189,30	171,74	125	25	70	8,10	125	25	120	13,80	125	30	180	20,84
13	P..28B013	204,20	185,75	130	25	70	9,00	130	25	120	16,00	130	30	180	24,70
14	P..28B014	218,20	199,76	130	25	70	10,50	130	25	120	18,80	130	30	180	28,93
15	P..28B015	232,30	213,79	145	25	70	12,00	160	25	120	21,80	145	30	180	34,58
16	P..28B016	246,30	227,84	160	30	75	15,00	160	30	120	25,50	160	30	180	40,44
17	P..28B017	260,00	241,90	160	30	75	16,00	160	30	120	28,00	160	30	180	45,77
18	P..28B018	274,00	255,98	160	30	75	17,00	160	30	120	31,00	160	30	180	51,76
19	P..28B019	289,00	270,06	160	30	75	18,50	180	30	120	36,00	180	30	180	58,07
20	P..28B020	303,00	284,15	160	30	75	20,00	180	30	120	39,80	180	30	180	64,49
21	P..28B021	317,00	298,24	160	30	75	22,00	180	30	120	42,80	180	40	180	71,28
22	P..28B022	331,00	312,34	Δ 170	30	75	23,50	Δ 180	30	120	46,80	180	40	180	78,61
23	P..28B023	345,00	326,44	Δ 170	30	75	25,00	Δ 180	30	120	50,50	Δ 180	40	180	85,94
24	P..28B024	359,00	340,55	Δ 170	30	75	26,50	Δ 180	30	120	52,69	Δ 180	40	180	99,01
25	P..28B025	373,00	354,66	Δ 170	30	75	28,00	Δ 180	30	120	59,00	Δ 180	40	180	112,07
26	P..28B026	387,00	368,77	Δ 170	30	75	29,50	Δ 180	40	120	61,36	Δ 180	40	180	116,66
27	P..28B027	401,00	382,88	Δ 170	30	75	30,03	Δ 180	40	120	63,72	Δ 180	40	180	121,25
28	P..28B028	416,00	397,00	Δ 170	30	75	32,50	Δ 180	40	120	66,08	Δ 180	40	180	125,84
29	P..28B029	430,00	411,12	Δ 170	30	75	33,66	Δ 180	40	120	68,44	Δ 180	40	180	130,43
30	P..28B030	444,00	425,24	Δ 170	30	75	38,00	Δ 180	40	120	70,80	Δ 180	40	180	148,79
31	P..28B031	458,00	439,37	Δ 180	30	75	39,26	Δ 200	40	120	73,16	Δ 200	40	180	149,28
32	P..28B032	472,00	453,49	Δ 180	30	75	40,53	Δ 200	40	120	75,52	Δ 200	40	180	156,08
33	P..28B033	486,00	467,62	Δ 180	30	75	41,79	Δ 200	40	120	77,88	Δ 200	40	180	162,88
34	P..28B034	500,00	481,75	Δ 180	30	75	44,33	Δ 200	40	120	80,24	Δ 200	40	180	169,68
35	P..28B035	514,00	495,88	Δ 180	30	75	51,00	Δ 200	40	120	82,60	Δ 200	40	180	176,48
36	P..28B036	529,00	510,01	Δ 180	30	75	52,45	Δ 200	40	120	84,96	Δ 200	40	180	183,28
37	P..28B037	543,00	524,13	Δ 180	30	75	53,91	Δ 200	40	120	87,32	Δ 200	40	180	190,08
38	P..28B038	557,00	538,27	Δ 180	30	75	59,00	Δ 200	40	120	89,68	Δ 200	40	180	244,01
39	P..28B039	571,00	552,40	Δ 180	30	75	64,00	Δ 200	40	120	92,04	Δ 200	40	180	257,56
40	P..28B040	585,00	566,54	Δ 180	30	75	65,64	Δ 200	40	120	94,40	Δ 200	40	180	271,10

*Änderungen der Abmessungen vorbehalten, wenden Sie sich bitte im Bedarfsfall an uns

Δ Kettenräder mit angeschweißter Nabe

.. 1 für einfach; 2 für zweifach; 3 für dreifach.



KETTENRÄDER AUS STAHL/ EDELSTAHL VORGEBOHRT 32B

B1	B2	B3	b1
29,4	87,4	146	28.8

TEILUNG: 2" x 1" 1/4
 TEILUNG: 50,8 x 30,99 mm
 MATERIAL: C45
 ROSTFREI 304L



Kettenrad mit einseitiger Nabe für Einfach-, Zweifach- und Dreifachrollenkettens laut folgenden Normen: DIN 8187 - ISO 606.

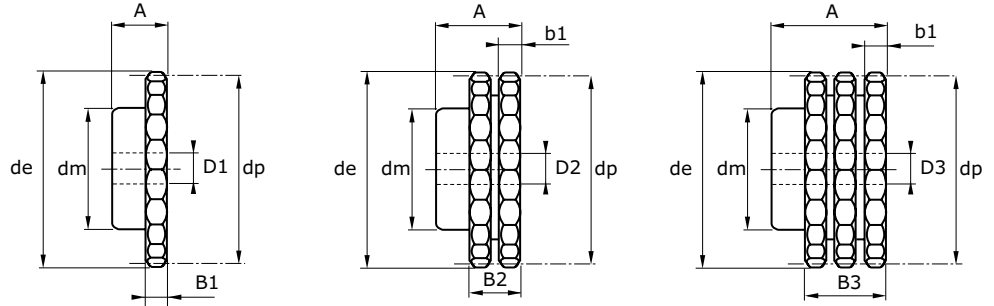

Abmessungen in mm

Z	Art. Nr.	de	dp	EINFACH				ZWEIFACH				DREIFACH			
				dm*	D1*	A*	Kg	dm*	D2*	A*	Kg	dm*	D3*	A*	Kg
8	P..32B008	153,20	132,74	82	25	80	4,70	82	30	120	7,50	82	30	180	9,90
9	P..32B009	169,00	148,54	88	25	80	6,20	88	30	120	9,50	88	30	180	13,65
10	P..32B010	185,00	164,39	104	25	80	8,00	104	30	120	12,40	104	30	180	17,97
11	P..32B011	200,80	180,31	120	30	80	9,50	120	30	120	14,80	120	30	180	22,22
12	P..32B012	216,80	196,29	133	30	80	11,40	133	30	120	17,60	133	30	180	27,23
13	P..32B013	232,80	212,29	145	30	80	13,50	145	30	120	21,50	145	30	180	32,98
14	P..32B014	248,80	228,29	160	30	80	15,50	160	30	120	24,50	160	30	180	38,50
15	P..32B015	264,80	244,30	160	30	80	17,00	160	30	120	27,70	160	30	180	45,04
16	P..32B016	280,90	260,40	160	30	90	20,00	160	30	120	31,20	160	30	180	51,50
17	P..32B017	296,90	276,46	170	30	90	21,50	180	30	120	36,50	180	30	180	61,45
18	P..32B018	313,00	292,55	170	30	90	23,00	180	30	120	40,50	180	30	180	68,85
19	P..32B019	329,10	308,66	170	30	90	24,50	200	30	120	45,50	200	30	180	46,73
20	P..32B020	345,20	324,71	180	30	90	28,00	200	30	120	48,00	200	30	180	85,07
21	P..32B021	361,30	340,82	180	30	90	29,50	200	30	120	54,50	200	40	180	93,89
22	P..32B022	377,50	356,98	Δ 180	30	90	30,90	Δ 200	30	120	57,10	200	40	180	103,41
23	P..32B023	393,60	373,08	Δ 180	30	90	33,00	Δ 200	30	120	64,00	Δ 200	40	180	112,93
24	P..32B024	409,70	389,18	Δ 180	30	90	34,43	Δ 200	30	120	66,78	Δ 200	40	180	128,63
25	P..32B025	425,80	405,33	Δ 180	30	90	37,50	Δ 200	30	120	75,00	Δ 200	40	180	133,86
26	P..32B026	441,90	421,44	Δ 180	30	90	39,00	Δ 200	30	120	78,00	Δ 200	40	180	141,43
27	P..32B027	458,20	437,59	Δ 180	30	90	40,50	Δ 200	40	120	81,00	Δ 200	40	180	149,00
28	P..32B028	474,50	453,69	Δ 180	30	90	42,00	Δ 200	30	120	84,00	Δ 200	40	180	156,57
29	P..32B029	492,00	469,85	Δ 180	30	90	43,50	Δ 200	40	120	87,00	Δ 200	40	180	164,14
30	P..32B030	506,50	486,00	Δ 180	30	90	45,00	Δ 200	40	120	108,00	Δ 200	40	180	194,42
32	P..32B032	538,80	518,27	Δ 200	30	90	46,45	Δ 200	40	120	115,20	Δ 200	40	180	230,96
35	P..32B035	589,50	566,71	Δ 200	30	90	50,80	Δ 200	40	120	126,00	Δ 200	40	180	267,49
38	P..32B038	635,50	615,16	Δ 200	30	90	55,15	Δ 200	40	120	136,80	Δ 200	40	180	316,22
40	P..32B040	670,30	647,47	Δ 200	30	90	58,05	Δ 200	40	120	144,00	Δ 200	40	180	364,95

*Änderungen der Abmessungen vorbehalten, wenden Sie sich bitte im Bedarfsfall an uns
 Δ Kettenräder mit angeschweißter Nabe
 .. 1 für einfach; 2 für zweifach; 3 für dreifach.

VORGEBOHRTE KETTENRADSCHLEIBEN DIN 03-1

B1
2,3

B2
-

B3
-

b1
-

TEILUNG: 5 x 2,5 mm
MATERIAL: Stahl

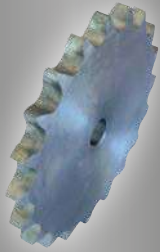

Kettenradschleiben für Einfachrollenkettens laut folgenden Normen: DIN 8187 - ISO 606.

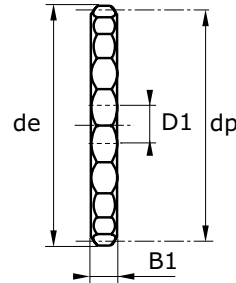

Abmessungen in mm

Z	Art. Nr.	EINFACH			
		de	dp	D1	Kg
8	D103B008	15,20	13,06	4	0,01
9	D103B009	16,80	14,62	4	0,01
10	D103B010	18,30	16,18	4	0,01
11	D103B011	19,90	17,75	5	0,01
12	D103B012	21,50	19,32	5	0,01
13	D103B013	23,00	20,89	5	0,01
14	D103B014	24,60	22,47	5	0,01
15	D103B015	26,20	24,04	5	0,01
16	D103B016	27,80	25,63	6	0,01
17	D103B017	29,40	27,20	6	0,01
18	D103B018	30,90	28,79	6	0,01
19	D103B019	32,50	30,38	6	0,01
20	D103B020	34,10	31,96	6	0,01
21	D103B021	35,70	33,54	8	0,01
22	D103B022	37,30	35,13	8	0,02
23	D103B023	38,90	36,72	8	0,02
24	D103B024	40,50	38,30	8	0,02
25	D103B025	42,00	39,89	8	0,02
26	D103B026	43,60	41,48	8	0,02
27	D103B027	45,20	43,07	8	0,02
28	D103B028	46,80	44,65	8	0,03
29	D103B029	48,40	46,25	8	0,03
30	D103B030	50,00	47,83	8	0,03
31	D103B031	51,60	49,42	8	0,03
32	D103B032	53,20	51,01	8	0,03
33	D103B033	54,80	52,60	8	0,04
34	D103B034	56,30	54,19	8	0,04
35	D103B035	57,90	55,78	8	0,04
36	D103B036	59,50	57,37	8	0,04
37	D103B037	61,10	58,96	8	0,05
38	D103B038	62,70	60,54	8	0,05
39	D103B039	64,30	62,13	8	0,05
40	D103B040	65,90	63,73	8	0,05
41	D103B041	67,50	65,31	8	0,06
42	D103B042	69,10	66,91	8	0,06
43	D103B043	70,60	68,49	8	0,06

Z	Art. Nr.	EINFACH			
		de	dp	D1	Kg
44	D103B044	72,20	70,09	8	0,07
45	D103B045	73,80	71,68	8	0,07
46	D103B046	75,40	73,27	8	0,07
47	D103B047	77,00	74,86	8	0,08
48	D103B048	78,60	76,45	8	0,08
49	D103B049	80,20	78,03	8	0,08
50	D103B050	81,80	79,63	8	0,08
51	D103B051	83,40	81,22	10	0,13
52	D103B052	85,00	82,81	10	0,17
53	D103B053	86,60	84,40	10	0,17
54	D103B054	88,10	85,97	10	0,18
55	D103B055	89,70	87,58	10	0,19
56	D103B056	91,30	89,17	10	0,20
57	D103B057	92,60	90,76	10	0,20
58	D103B058	94,50	92,35	10	0,21
59	D103B059	96,10	93,94	10	0,22
60	D103B060	97,70	95,53	10	0,23
62	D103B062	100,90	98,72	12	0,24
64	D103B064	104,10	101,90	12	0,26
65	D103B065	105,60	103,49	12	0,27
66	D103B066	107,20	105,08	12	0,28
68	D103B068	110,40	108,26	12	0,30
70	D103B070	113,60	111,44	12	0,31
72	D103B072	116,80	114,63	12	0,34
75	D103B075	121,60	119,40	12	0,36
76	D103B076	123,10	120,99	12	0,37
78	D103B078	126,30	124,17	12	0,39
80	D103B080	129,50	127,35	12	0,41
85	D103B085	137,50	135,31	14	0,46
90	D103B090	145,40	143,27	14	0,52
95	D103B095	153,40	151,22	14	0,58
100	D103B100	161,30	159,18	14	0,65
110	D103B110	177,20	175,09	14	0,79
114	D103B114	183,60	181,46	14	0,85
120	D103B120	193,20	191,01	14	0,95
125	D103B125	201,10	198,96	14	1,03



VORGEBOHRTE KETTENRADSCHLEIBEN DIN 04-1

B1 2,6
B2 -
B3 -
b1 -

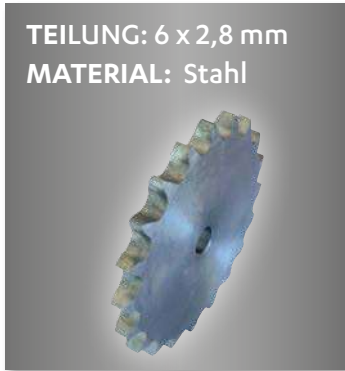

Kettenradschleiben für Einfachrollenkettens laut folgenden Normen: DIN 8187 - ISO 606.

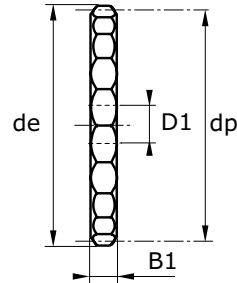

Abmessungen in mm

Z	Art. Nr.	de	dp	D1	Kg
8	D104B008	18,00	15,67	5	0,01
9	D104B009	19,90	17,54	5	0,01
10	D104B010	21,70	19,42	6	0,01
11	D104B011	23,70	21,30	6	0,01
12	D104B012	25,40	23,18	6	0,01
13	D104B013	27,30	25,05	8	0,01
14	D104B014	29,20	26,96	8	0,01
15	D104B015	31,10	28,86	8	0,01
16	D104B016	33,00	30,76	8	0,01
17	D104B017	35,00	32,65	8	0,01
18	D104B018	36,90	34,55	8	0,02
19	D104B019	38,80	36,44	8	0,02
20	D104B020	40,70	38,44	8	0,02
21	D104B021	42,60	40,25	8	0,02
22	D104B022	44,50	42,16	8	0,02
23	D104B023	46,40	44,06	8	0,03
24	D104B024	48,30	45,96	8	0,03
25	D104B025	50,20	47,87	8	0,03
26	D104B026	52,10	49,77	8	0,03
27	D104B027	54,00	51,67	8	0,04
28	D104B028	55,90	53,58	8	0,04
29	D104B029	57,80	55,50	10	0,04
30	D104B030	59,80	57,42	10	0,05
31	D104B031	61,70	59,31	10	0,05
32	D104B032	63,60	61,21	10	0,05
33	D104B033	65,50	63,11	10	0,06
34	D104B034	67,40	65,02	10	0,06
35	D104B035	69,30	66,93	10	0,07
36	D104B036	71,20	68,84	10	0,07
37	D104B037	73,10	70,75	10	0,07
38	D104B038	75,00	72,66	10	0,08
39	D104B039	76,90	74,56	10	0,08
40	D104B040	78,90	76,47	10	0,09
41	D104B041	80,80	78,38	12	0,09
42	D104B042	82,70	80,28	12	0,10
43	D104B043	84,70	82,19	12	0,10

Z	Art. Nr.	de	dp	D1	Kg
44	D104B044	86,60	84,10	12	0,10
45	D104B045	88,50	86,01	12	0,10
46	D104B046	90,40	87,92	12	0,10
47	D104B047	92,30	89,83	12	0,10
48	D104B048	94,20	91,74	12	0,10
49	D104B049	96,10	93,64	12	0,10
50	D104B050	98,00	95,55	12	0,11
51	D104B051	99,90	97,47	12	0,11
52	D104B052	101,80	99,37	12	0,11
53	D104B053	103,70	101,27	12	0,11
54	D104B054	105,60	103,17	12	0,12
55	D104B055	107,60	105,08	12	0,12
56	D104B056	109,50	107,00	12	0,20
57	D104B057	111,40	108,93	12	0,20
58	D104B058	113,30	110,82	12	0,20
59	D104B059	115,20	112,71	12	0,20
60	D104B060	117,50	114,62	12	0,20
62	D104B062	120,90	118,45	16	0,20
64	D104B064	124,70	122,27	16	0,20
65	D104B065	126,60	124,18	16	0,30
66	D104B066	128,50	126,09	16	0,30
68	D104B068	132,40	129,91	16	0,34
70	D104B070	136,20	133,73	16	0,35
72	D104B072	140,00	137,55	16	0,36
75	D104B075	145,70	143,28	16	0,37
76	D104B076	147,60	145,19	16	0,48
78	D104B078	151,50	149,01	16	0,50
80	D104B080	155,30	152,82	16	0,52
85	D104B085	164,80	162,37	16	0,60
90	D104B090	174,40	171,92	16	0,63
95	D104B095	183,90	181,47	16	0,67
100	D104B100	193,50	191,01	16	0,80
110	D104B110	211,60	210,11	16	0,88
114	D104B114	220,20	217,75	16	0,91
120	D104B120	231,70	229,20	16	0,96
125	D104B125	241,20	238,75	16	1,50

VORGEBOHRTE KETTENRADSCHLEIBEN 05B

B1 2,8
B2 -
B3 -
b1 -

TEILUNG: 8 x 3 mm
MATERIAL: Stahl

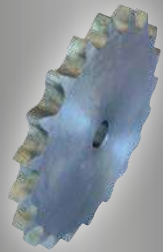

Kettenradschleiben für Einfachrollenkettens laut folgenden Normen: DIN 8187 - ISO 606.

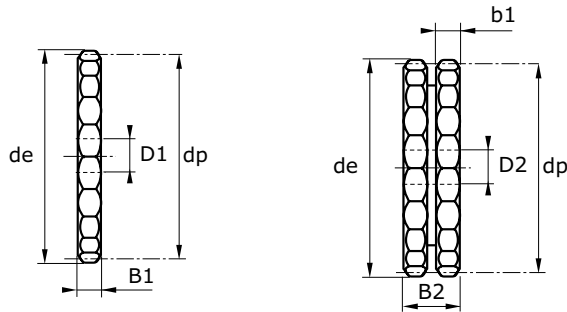

Abmessungen in mm

Z	Art. Nr.	de	dp	EINFACH		ZWEIFACH	
				D1	Kg	D2	Kg
8	D..5B008	24,00	20,90	6	0,01	6	0,01
9	D..05B009	26,60	23,39	6	0,01	6	0,01
10	D..05B010	29,20	25,89	8	0,02	8	0,02
11	D..05B011	31,70	28,39	8	0,02	8	0,02
12	D..05B012	34,20	30,91	8	0,02	8	0,03
13	D..05B013	36,70	33,42	8	0,02	8	0,04
14	D..05B014	39,20	35,95	8	0,02	8	0,05
15	D..05B015	41,70	38,48	8	0,03	8	0,06
16	D..05B016	44,30	41,01	8	0,03	10	0,07
17	D..05B017	46,80	43,53	8	0,03	10	0,08
18	D..05B018	49,30	46,07	8	0,04	10	0,09
19	D..05B019	51,90	48,61	8	0,04	10	0,10
20	D..05B020	54,40	51,14	8	0,04	10	0,12
21	D..05B021	57,00	53,67	10	0,04	10	0,13
22	D..05B022	59,50	56,21	10	0,05	10	0,14
23	D..05B023	62,00	58,75	10	0,05	10	0,16
24	D..05B024	64,00	61,29	10	0,06	10	0,17
25	D..05B025	67,50	63,83	10	0,07	10	0,18
26	D..05B026	69,50	66,37	10	0,07	12	0,19
27	D..05B027	72,20	68,91	10	0,08	12	0,20
28	D..05B028	74,80	71,45	10	0,08	12	0,22
29	D..05B029	77,30	73,99	10	0,09	12	0,24
30	D..05B030	79,80	76,53	10	0,10	12	0,25
31	D..05B031	82,40	79,08	10	0,10	12	0,27
32	D..05B032	84,90	81,61	10	0,11	12	0,29
33	D..05B033	87,50	84,16	10	0,11	12	0,31
34	D..05B034	90,00	86,70	10	0,12	12	0,34
35	D..05B035	92,50	89,24	10	0,12	12	0,36
36	D..05B036	95,00	91,79	10	0,13	12	0,38
37	D..05B037	97,60	94,33	12	0,16	12	0,40
38	D..05B038	100,20	96,88	12	0,20	12	0,42
39	D..05B039	102,70	99,42	12	0,21	12	0,44
40	D..05B040	105,20	101,97	12	0,23	12	0,47
41	D..05B041	107,80	104,51	12	0,24	14	0,49
42	D..05B042	110,40	107,05	12	0,26	14	0,52
43	D..05B043	112,90	109,60	12	0,28	14	0,55

Z	Art. Nr.	de	dp	EINFACH		ZWEIFACH	
				D1	Kg	D2	Kg
44	D..05B044	115,50	112,14	12	0,24	14	0,58
45	D..05B045	118,00	114,69	12	0,29	14	0,60
46	D..05B046	120,60	117,23	12	0,31	14	0,63
47	D..05B047	123,10	119,77	12	0,32	14	0,66
48	D..05B048	125,60	122,32	12	0,34	14	0,69
49	D..05B049	128,20	124,86	12	0,35	14	0,72
50	D..05B050	130,70	127,41	12	0,36	14	0,75
51	D..05B051	133,30	129,95	14	0,37	16	0,79
52	D..05B052	135,80	132,49	14	0,39	16	0,82
53	D..05B053	138,40	135,04	14	0,41	16	0,86
54	D..05B054	140,90	137,59	14	0,42	16	0,90
55	D..05B055	143,50	140,13	14	0,45	16	0,93
56	D..05B056	146,00	142,68	14	0,47	16	0,96
57	D..05B057	148,50	145,22	14	0,48	16	0,99
58	D..05B058	151,00	147,77	14	0,50	16	1,04
59	D..05B059	153,60	150,31	14	0,53	16	1,08
60	D..05B060	156,20	152,85	16	0,54	16	1,11
62	D..05B062	162,00	157,95	16	0,57	20	1,17
64	D..05B064	167,10	163,04	16	0,61	20	1,23
65	D..05B065	169,20	165,58	16	0,63	20	1,30
66	D..05B066	172,20	168,13	16	0,67	20	1,38
68	D..05B068	177,30	173,22	16	0,70	20	1,46
70	D..05B070	182,40	178,31	16	0,73	20	1,54
72	D..05B072	187,50	183,41	16	0,82	20	1,62
75	D..05B075	195,10	191,04	20	0,85	20	1,70
76	D..05B076	197,70	193,59	20	0,87	20	1,80
78	D..05B078	202,80	198,68	20	0,89	20	1,90
80	D..05B080	207,90	203,77	20	0,64	20	2
85	D..05B085	220,60	216,50	20	1,10	20	2,2
90	D..05B090	233,40	229,23	20	1,08	20	2,4
95	D..05B095	246,10	241,96	20	1,35	20	2,6
100	D..05B100	258,90	254,68	20	1,50	20	2,8
110	D..05B110	284,30	280,15	20	1,72	20	3,5
114	D..05B114	294,50	290,33	20	1,95	20	4,15
120	D..05B120	310,00	305,61	20	2,15	20	5
125	D..05B125	322,50	318,34	20	3,35	20	5,5



VORGEBOHRTE KETTENRADSCHLEIBEN 06B

B1 5,3
B2 15,4
B3 25,6
b1 5,2

TEILUNG: 3/8" x 7/32"
TEILUNG: 9,525 x 5,72 mm
MATERIAL: Stahl

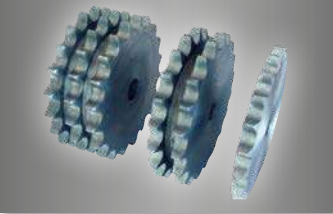

Kettenradschleiben für Einfach-, Zweifach- und Dreifachrollenkettens laut folgenden Normen: DIN 8187 - ISO 606.

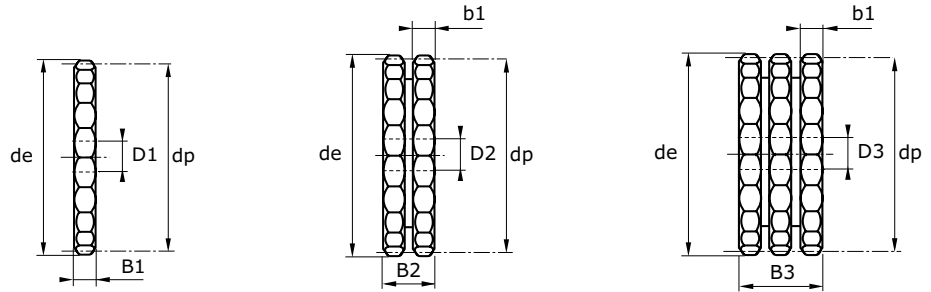

Abmessungen in mm

Z	Art. Nr.	de	dp	EINFACH		ZWEIFACH		DREIFACH	
				D1	Kg	D2	Kg	D3	Kg
8	D..06B008	28,00	24,89	6	0,01	8	0,03	8	0,10
9	D..06B009	31,00	27,85	8	0,02	8	0,04	8	0,10
10	D..06B010	34,00	30,82	8	0,02	8	0,06	10	0,10
11	D..06B011	37,00	33,80	8	0,03	10	0,06	12	0,90
12	D..06B012	40,00	36,80	8	0,04	10	0,08	12	0,12
13	D..06B013	43,00	39,80	8	0,04	10	0,10	12	0,15
14	D..06B014	46,30	42,80	8	0,05	10	0,12	12	0,18
15	D..06B015	49,30	45,81	8	0,06	10	0,14	12	0,22
16	D..06B016	52,30	48,82	10	0,07	12	0,16	12	0,26
17	D..06B017	55,30	51,83	10	0,07	12	0,19	12	0,30
18	D..06B018	58,30	54,85	10	0,08	12	0,21	12	0,35
19	D..06B019	61,30	57,87	10	0,09	12	0,24	12	0,39
20	D..06B020	64,30	60,89	10	0,10	12	0,27	12	0,44
21	D..06B021	68,00	63,91	10	0,12	12	0,30	16	0,48
22	D..06B022	71,00	66,93	10	0,13	12	0,34	16	0,54
23	D..06B023	73,50	69,95	10	0,14	12	0,37	16	0,59
24	D..06B024	77,00	72,97	10	0,15	12	0,41	16	0,66
25	D..06B025	80,00	76,00	10	0,17	12	0,45	16	0,72
26	D..06B026	83,00	79,02	10	0,18	16	0,48	16	0,79
27	D..06B027	86,00	82,04	10	0,20	16	0,53	16	0,86
28	D..06B028	89,00	85,07	10	0,21	16	0,57	16	0,93
29	D..06B029	92,00	88,09	10	0,23	16	0,62	16	1,01
30	D..06B030	94,70	91,12	10	0,25	16	0,66	16	1,09
31	D..06B031	98,30	94,15	12	0,26	16	0,71	16	1,17
32	D..06B032	101,30	97,17	12	0,28	16	0,77	16	1,26
33	D..06B033	104,30	100,20	12	0,30	16	0,82	16	1,35
34	D..06B034	107,30	103,23	12	0,32	16	0,87	16	1,44
35	D..06B035	110,40	106,26	12	0,34	16	0,93	16	1,53
36	D..06B036	113,40	109,29	12	0,36	16	0,99	20	1,61
37	D..06B037	116,40	112,32	12	0,38	16	1,05	20	1,71
38	D..06B038	119,50	115,34	12	0,40	16	1,11	20	1,81
39	D..06B039	122,50	118,37	12	0,43	16	1,18	20	1,92
40	D..06B040	125,50	121,40	12	0,45	16	1,24	20	2,02
41	D..06B041	128,50	124,43	16	0,47	20	1,30	20	2,14
42	D..06B042	131,60	127,46	16	0,49	20	1,36	20	2,25
43	D..06B043	134,60	130,49	16	0,52	20	1,44	20	3,37

Z	Art. Nr.	de	dp	EINFACH		ZWEIFACH		DREIFACH	
				D1	Kg	D2	Kg	D3	Kg
44	D..06B044	137,60	133,52	16	0,55	20	1,51	20	2,49
45	D..06B045	140,70	136,54	16	0,57	20	1,58	20	2,61
46	D..06B046	143,70	139,58	16	0,60	20	1,66	20	2,71
47	D..06B047	146,70	142,61	16	0,63	20	1,74	20	2,80
48	D..06B048	149,70	145,64	16	0,65	20	1,82	20	2,99
49	D..06B049	152,70	148,66	16	0,68	20	1,90	20	3,13
50	D..06B050	155,70	151,69	20	0,71	20	1,98	20	3,27
51	D..06B051	158,70	154,72	20	0,74	20	2,06	20	3,40
52	D..06B052	161,80	157,75	20	0,77	20	2,15	20	3,48
53	D..06B053	166,80	160,78	20	0,80	20	2,22	20	3,57
54	D..06B054	167,80	163,82	20	0,83	20	2,33	20	3,66
55	D..06B055	170,80	166,85	20	0,86	20	2,42	20	3,75
56	D..06B056	173,80	169,88	20	0,89	20	2,51	25	3,84
57	D..06B057	176,90	172,91	20	0,93	20	2,61	25	4,28
58	D..06B058	179,90	175,93	20	0,96	20	2,71	25	4,44
60	D..06B060	186,00	181,99	20	1,03	20	2,91	25	4,77
62	D..06B062	192,10	188,06	20	1,10	25	3,09	25	5,12
64	D..06B064	198,30	194,12	20	1,18	25	3,30	25	5,46
65	D..06B065	201,60	197,15	20	1,21	25	3,40	25	5,64
66	D..06B066	204,60	200,18	20	1,25	25	3,57	25	5,83
68	D..06B068	210,70	206,24	20	1,33	25	3,75	25	6,21
70	D..06B070	216,70	212,30	20	1,41	25	3,99	25	6,59
72	D..06B072	222,80	218,37	20	1,50	25	4,23	25	6,99
75	D..06B075	232,90	227,46	20	1,63	25	4,60	25	7,41
76	D..06B076	234,90	230,49	20	1,67	25	4,73	25	7,83
78	D..06B078	241,00	236,55	20	1,76	25	4,99	25	8,27
80	D..06B080	247,10	242,61	20	1,86	25	5,26	25	8,71
85	D..06B085	262,20	257,77	25	2,10	25	5,96	25	9,87
90	D..06B090	277,40	272,93	25	2,36	25	6,71	25	11,11
95	D..06B095	292,50	288,08	25	2,63	25	7,50	25	12,42
100	D..06B100	307,70	303,25	25	2,92	25	8,34	25	13,81
110	D..06B110	338,00	333,55	25	3,54	25	10,14	25	15,94
114	D..06B114	349,50	345,68	25	3,81	25	10,90	25	18,06
120	D..06B120	368,30	363,86	25	4,23	25	12,11	25	19,94
125	D..06B125	383,50	379,02	25	4,59	25	13,16	25	21,81

.. 1 für einfach; 2 für zweifach; 3 für dreifach.

VORGEBOHRTE KETTENRADSCHLEIBEN 081

B1	B2	B3	b1
3	-	-	-

TEILUNG: 1/2" x 1/8"
 TEILUNG: 12,7 x 3,3 mm
 MATERIAL: Stahl

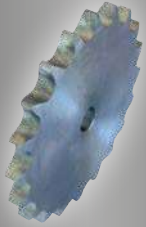

Kettenradschleiben für Einfachrollenkettens laut folgenden Normen: DIN 8187 - ISO 606.

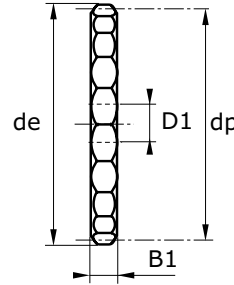

Abmessungen in mm

Z	Art. Nr.	EINFACH			
		de	dp	D1	Kg
8	D1081008	37,20	33,18	8	0,01
9	D1081009	41,50	37,13	8	0,02
10	D1081010	46,20	41,10	8	0,02
11	D1081011	49,60	45,07	8	0,03
12	D1081012	53,90	49,07	8	0,04
13	D1081013	58,40	53,06	8	0,04
14	D1081014	62,80	57,07	8	0,05
15	D1081015	66,80	61,09	8	0,06
16	D1081016	70,90	65,10	8	0,07
17	D1081017	74,90	69,11	8	0,08
18	D1081018	78,90	73,14	8	0,09
19	D1081019	82,90	77,16	8	0,10
20	D1081020	86,90	81,19	8	0,11
21	D1081021	91,00	85,22	8	0,11
22	D1081022	95,00	89,24	10	0,13
23	D1081023	99,00	93,27	10	0,15
24	D1081024	103,00	97,29	12	0,16
25	D1081025	107,10	101,29	12	0,17
26	D1081026	111,20	105,36	12	0,26
27	D1081027	115,40	109,40	12	0,28
28	D1081028	119,40	113,42	12	0,32
29	D1081029	123,40	117,46	12	0,33
30	D1081030	127,50	121,50	12	0,35
31	D1081031	131,50	125,54	12	0,37
32	D1081032	135,50	129,56	12	0,40
33	D1081033	139,60	133,60	12	0,43
34	D1081034	143,60	137,64	12	0,46
35	D1081035	147,60	141,68	12	0,49
36	D1081036	151,70	145,72	16	0,51
37	D1081037	155,70	149,76	16	0,55
38	D1081038	159,80	153,80	16	0,58
39	D1081039	163,80	157,83	16	0,61
40	D1081040	167,80	161,87	16	0,64
41	D1081041	171,40	165,91	16	0,66
42	D1081042	175,40	169,65	16	0,69
43	D1081043	179,50	173,99	16	0,72

Z	Art. Nr.	EINFACH			
		de	dp	D1	Kg
44	D1081044	183,50	178,03	16	0,79
45	D1081045	187,50	182,07	16	0,82
46	D1081046	191,60	186,10	16	0,85
47	D1081047	195,60	190,14	16	0,03
48	D1081048	199,70	194,18	20	0,94
49	D1081049	203,70	198,22	20	0,96
50	D1081050	207,80	202,26	20	0,99
51	D1081051	211,80	206,30	20	1,01
52	D1081052	215,90	210,34	20	1,04
53	D1081053	219,90	214,37	20	1,06
54	D1081054	224,00	218,43	20	1,10
55	D1081055	228,00	222,46	20	1,25
56	D1081056	232,10	226,50	20	1,30
57	D1081057	236,10	230,54	20	1,35
58	D1081058	240,20	234,58	20	1,38
59	D1081059	244,20	238,62	20	1,43
60	D1081060	248,20	242,66	20	1,50
62	D1081062	256,70	250,75	20	1,55
64	D1081064	264,80	258,82	20	1,61
65	D1081065	268,80	262,86	20	1,66
66	D1081066	272,90	266,90	25	1,72
68	D1081068	280,90	274,99	25	1,80
70	D1081070	289,00	283,07	25	2,05
72	D1081072	297,10	291,16	25	2,13
76	D1081076	313,30	307,33	25	2,29
78	D1081078	321,40	315,40	25	2,37
80	D1081080	329,40	323,48	25	2,45
85	D1081085	349,70	343,70	25	2,54
90	D1081090	369,90	363,90	25	2,62
95	D1081095	390,10	384,10	25	2,70
100	D1081100	410,30	404,31	25	2,78
110	D1081110	450,70	444,74	25	2,86
114	D1081114	466,90	460,90	25	2,95
120	D1081120	491,20	485,16	25	3,94
125	D1081125	511,40	505,37	25	4,00



VORGEBOHRTE KETTENRADSCHLEIBEN 083

B1 4,5
B2 -
B3 -
b1 -

TEILUNG: 1/2" x 3/16"
TEILUNG: 12,7 x 4,88 mm
MATERIAL: Stahl

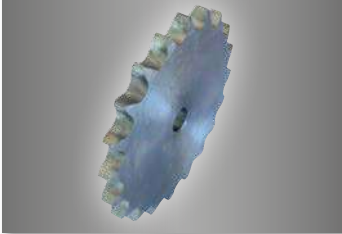

Kettenradschleiben für Einfachrollenkettens laut folgenden Normen: DIN 8187 - ISO 606.

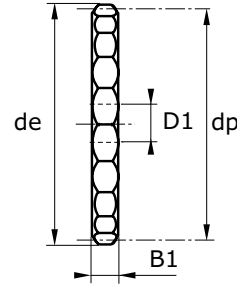

Abmessungen in mm

Z	Art. Nr.	EINFACH			
		de	dp	D1	Kg
8	D1083008	38,50	33,18	8	0,02
9	D1083009	41,50	37,13	8	0,03
10	D1083010	46,20	41,10	8	0,04
11	D1083011	49,60	45,07	8	0,05
12	D1083012	53,90	49,07	8	0,05
13	D1083013	58,40	53,06	8	0,06
14	D1083014	62,80	57,07	8	0,08
15	D1083015	66,80	61,09	8	0,09
16	D1083016	70,90	65,10	8	0,10
17	D1083017	74,90	69,11	8	0,12
18	D1083018	78,90	73,14	8	0,13
19	D1083019	82,90	77,16	8	0,15
20	D1083020	86,90	81,19	8	0,16
21	D1083021	91,00	85,22	8	0,18
22	D1083022	95,00	89,24	10	0,20
23	D1083023	99,00	93,27	10	0,22
24	D1083024	103,00	97,29	12	0,24
25	D1083025	107,10	101,33	12	0,26
26	D1083026	111,20	105,36	12	0,28
27	D1083027	115,40	109,40	12	0,30
28	D1083028	119,40	113,42	12	0,33
29	D1083029	123,40	117,46	12	0,35
30	D1083030	127,50	121,50	12	0,38
31	D1083031	131,50	125,54	12	0,40
32	D1083032	135,50	129,56	12	0,43
33	D1083033	139,60	133,60	12	0,46
34	D1083034	143,60	137,64	12	0,49
35	D1083035	145,60	141,68	12	0,52
36	D1083036	151,70	145,42	16	0,55
37	D1083037	155,70	149,76	16	0,58
38	D1083038	159,80	153,80	16	0,62
39	D1083039	163,80	157,83	16	0,65
40	D1083040	167,80	161,87	16	0,68
41	D1083041	171,40	165,91	16	0,72
42	D1083042	175,40	169,95	16	0,76
43	D1083043	179,50	173,99	16	0,80

Z	Art. Nr.	EINFACH			
		de	dp	D1	Kg
44	D1083044	183,50	178,03	16	0,83
45	D1083045	187,50	182,07	16	0,87
46	D1083046	191,50	186,10	20	0,91
47	D1083047	195,60	190,14	20	0,95
48	D1083048	199,70	194,18	20	0,99
49	D1083049	203,70	198,22	20	1,04
50	D1083050	207,80	202,26	20	1,08
51	D1083051	211,80	206,30	20	0,75
52	D1083052	215,90	210,34	20	0,77
53	D1083053	219,90	214,37	20	0,80
54	D1083054	224,00	218,43	20	0,82
55	D1083055	228,00	222,46	20	0,84
56	D1083056	232,10	226,50	20	0,90
57	D1083057	236,10	230,54	20	0,93
58	D1083058	240,20	234,58	20	0,95
59	D1083059	244,20	238,62	20	0,98
60	D1083060	248,20	242,66	20	1,00
62	D1083061	256,70	250,76	20	1,07
64	D1083064	264,30	258,82	20	1,14
65	D1083065	268,80	262,86	20	1,17
66	D1083066	272,90	267,90	25	1,18
68	D1083068	280,90	274,99	25	1,25
70	D1083070	289,00	283,07	25	1,34
72	D1083072	297,10	291,16	25	1,38
76	D1083076	313,30	307,33	25	1,66
78	D1083078	321,40	315,40	25	1,70
80	D1083080	329,40	323,48	25	1,78
85	D1083085	349,70	343,69	25	1,90
90	D1083090	369,90	363,90	25	2,29
95	D1083095	390,90	384,11	25	2,54
100	D1083100	410,30	404,31	25	2,83
110	D1083110	450,70	444,74	25	3,13
114	D1083114	466,90	460,90	25	3,65
120	D1083120	491,20	485,16	25	3,84
125	D1083125	511,60	505,37	25	4,00

VORGEBOHRTE KETTENRADSCHLEIBEN 08B

B1 7,2
B2 21
B3 34,9
b1 7

TEILUNG: 1/2" x 5/16"
TEILUNG: 12,7 x 7,75 mm
MATERIAL: Stahl

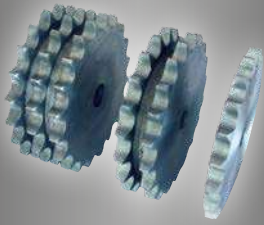

Kettenradschleiben für Einfach-, Zweifach- und Dreifachrollenkettens laut folgenden Normen:
DIN 8187 - ISO 606.

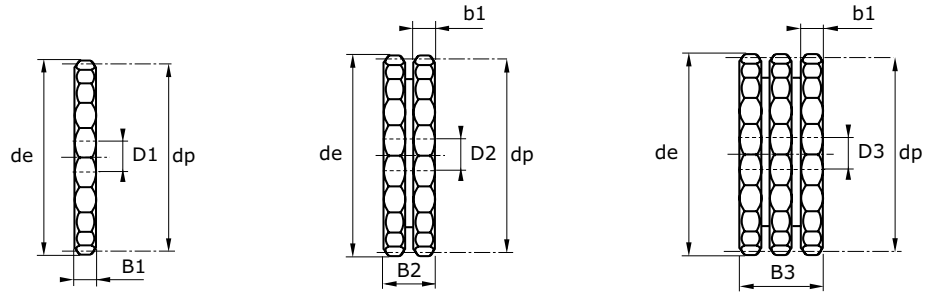

Abmessungen in mm

Z	Art. Nr.	de	dp	EINFACH		ZWEIFACH		DREIFACH	
				D1	Kg	D2	Kg	D3	Kg
8	D..08B008	37,20	33,18	8	0,03	10	0,08	10	0,11
9	D..08B009	41,00	37,13	8	0,04	10	0,11	10	0,16
10	D..08B010	45,20	41,10	8	0,06	10	0,13	10	0,21
11	D..08B011	48,70	45,07	10	0,07	10	0,17	12	0,26
12	D..08B012	53,00	49,07	10	0,08	10	0,21	12	0,33
13	D..08B013	57,40	53,06	10	0,10	10	0,25	12	0,40
14	D..08B014	61,80	57,07	10	0,12	10	0,30	12	0,48
15	D..08B015	65,50	61,09	10	0,14	10	0,36	12	0,57
16	D..08B016	69,50	65,10	10	0,16	12	0,41	16	0,64
17	D..08B017	73,60	69,11	10	0,18	12	0,47	16	0,74
18	D..08B018	77,80	73,14	10	0,20	12	0,54	16	0,85
19	D..08B019	81,70	77,16	10	0,23	12	0,61	16	0,97
20	D..08B020	86,80	81,19	10	0,26	12	0,68	16	1,09
21	D..08B021	89,70	85,22	12	0,28	16	0,75	16	1,22
22	D..08B022	93,80	89,24	12	0,31	16	0,83	16	1,36
23	D..08B023	98,20	93,27	12	0,34	16	0,92	16	1,50
24	D..08B024	101,80	97,29	12	0,38	16	1,01	16	1,63
25	D..08B025	105,80	101,33	12	0,41	16	1,10	16	1,81
26	D..08B026	110,00	105,36	16	0,44	16	1,20	16	1,98
27	D..08B027	114,00	109,40	16	0,48	16	1,31	16	2,15
28	D..08B028	118,00	113,42	16	0,52	16	1,42	16	2,33
29	D..08B029	120,00	117,46	16	0,56	16	1,53	16	2,52
30	D..08B030	126,40	121,50	16	0,60	16	1,65	16	2,71
31	D..08B031	130,20	125,54	16	0,64	16	1,77	20	2,96
32	D..08B032	134,30	129,56	16	0,68	16	1,90	20	3,09
33	D..08B033	138,60	133,60	16	0,73	16	2,02	20	3,30
34	D..08B034	142,70	137,64	16	0,78	16	2,16	20	3,53
35	D..08B035	146,00	141,68	16	0,83	16	2,30	20	3,76
36	D..08B036	151,00	145,72	16	0,88	20	2,42	20	3,99
37	D..08B037	154,60	149,76	16	0,93	20	2,56	20	4,24
38	D..08B038	158,60	153,80	16	0,98	20	2,71	20	4,49
39	D..08B039	162,70	157,83	16	1,03	20	2,87	20	4,74
40	D..08B040	166,70	161,87	16	1,09	20	3,03	20	5,00
41	D..08B041	171,40	165,91	20	1,14	20	3,20	25	5,07
42	D..08B042	175,40	169,95	20	1,20	20	3,36	25	5,51
43	D..08B043	179,70	173,99	20	1,26	20	3,53	25	5,80

Z	Art. Nr.	de	dp	EINFACH		ZWEIFACH		DREIFACH	
				D1	Kg	D2	Kg	D3	Kg
44	D..08B044	183,80	178,03	20	1,32	20	3,71	25	6,09
45	D..08B045	188,00	182,07	20	1,38	20	3,89	25	6,39
46	D..08B046	192,10	186,10	20	1,45	20	4,07	25	6,70
47	D..08B047	196,20	190,14	20	1,51	20	4,25	25	7,00
48	D..08B048	200,30	194,18	20	1,58	20	4,96	25	7,33
49	D..08B049	204,30	198,22	20	1,65	20	4,66	25	7,66
50	D..08B050	208,30	202,26	20	1,72	20	4,86	25	8,00
51	D..08B051	212,10	206,30	20	1,80	25	5,03	25	8,26
52	D..08B052	216,10	210,34	20	1,87	25	5,24	25	8,68
53	D..08B053	220,20	214,37	20	1,94	25	5,46	25	9,04
54	D..08B054	224,10	218,43	20	2,02	25	5,68	25	9,40
55	D..08B055	228,10	222,46	20	2,10	25	5,90	25	9,77
56	D..08B056	232,20	226,50	20	2,17	25	6,13	25	10,15
57	D..08B057	236,40	230,54	20	2,25	25	6,36	25	10,53
58	D..08B058	240,50	234,58	20	2,34	25	6,59	25	10,83
59	D..08B059	244,50	238,62	20	2,42	25	6,83	25	11,28
60	D..08B060	248,60	242,66	20	2,50	25	7,08	25	11,73
62	D..08B062	256,90	250,75	25	2,67	25	7,60	25	12,56
64	D..08B064	265,10	258,82	25	2,85	25	8,10	25	13,40
65	D..08B065	269,00	262,86	25	2,94	25	8,36	25	13,86
66	D..08B066	273,00	266,90	25	3,03	25	8,78	25	14,54
68	D..08B068	281,00	274,99	25	3,22	25	9,20	25	15,22
70	D..08B070	289,00	283,07	25	3,42	25	9,75	25	16,17
72	D..08B072	297,20	291,16	25	3,62	25	10,33	25	17,14
75	D..08B075	309,20	303,27	25	3,94	25	11,24	25	18,65
76	D..08B076	313,30	307,33	25	4,05	25	11,55	25	19,17
78	D..08B078	321,40	315,40	25	4,27	25	12,22	25	19,70
80	D..08B080	329,40	323,48	25	4,50	25	12,90	25	21,82
85	D..08B085	349,00	343,69	25	5,62	25	14,55	25	24,15
90	D..08B090	369,90	363,90	25	6,31	25	16,36	25	27,17
95	D..08B095	390,10	384,11	25	7,05	25	18,28	25	30,36
100	D..08B100	410,30	404,31	25	7,82	25	20,30	25	33,73
110	D..08B110	450,70	444,74	25	9,50	25	24,67	25	35,20
114	D..08B114	466,90	460,90	25	10,21	25	26,53	25	44,10
120	D..08B120	491,20	485,16	25	11,32	25	29,46	25	45,00
125	D..08B125	511,30	505,37	25	12,31	25	32,00	25	55,21

.. 1 für einfach; 2 für zweifach; 3 für dreifach.



VORGEBOHRTE KETTENRADSCHLEIBEN 10B

B1	B2	B3	b1
9,1	25,5	42,1	9



Kettenradschleiben für Einfach-, Zweifach- und Dreifachrollenkettens laut folgenden Normen:
DIN 8187 - ISO 606.

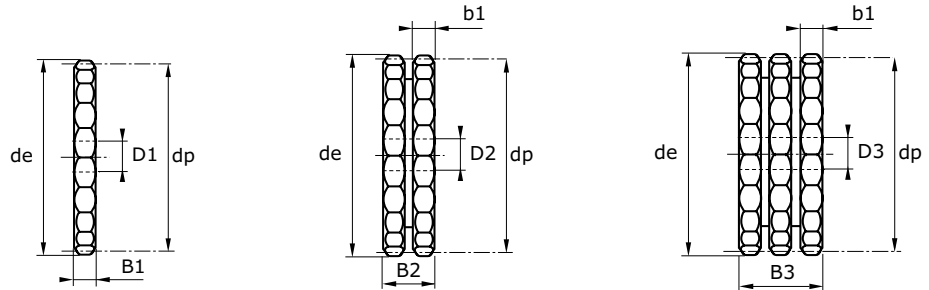

Abmessungen in mm

Z	Art. Nr.	de	dp	EINFACH		ZWEIFACH		DREIFACH	
				D1	Kg	D2	Kg	D3	Kg
8	D..10B008	48,00	41,48	10	0,06	10	0,15	12	0,23
9	D..10B009	52,60	46,42	10	0,09	10	0,21	12	0,32
10	D..10B010	57,50	51,37	10	0,11	10	0,22	12	0,45
11	D..10B011	63,00	56,34	10	0,14	12	0,34	12	0,57
12	D..10B012	68,00	61,34	10	0,17	12	0,42	12	0,67
13	D..10B013	73,00	66,32	10	0,20	12	0,51	12	0,81
14	D..10B014	78,00	71,34	12	0,23	12	0,60	12	0,97
15	D..10B015	83,00	76,36	12	0,27	12	0,70	12	1,14
16	D..10B016	88,00	81,37	12	0,31	12	0,82	16	1,29
17	D..10B017	93,00	86,39	12	0,36	12	0,94	16	1,49
18	D..10B018	98,30	91,42	12	0,41	12	1,06	16	1,70
19	D..10B019	103,30	96,45	12	0,46	12	1,20	16	1,92
20	D..10B020	108,40	101,49	12	0,51	12	1,34	16	2,15
21	D..10B021	113,40	106,52	12	0,57	16	1,48	16	2,40
22	D..10B022	118,00	111,55	12	0,62	16	1,64	16	2,66
23	D..10B023	123,50	116,58	12	0,69	16	1,80	16	2,94
24	D..10B024	128,30	121,62	12	0,75	16	1,98	16	3,23
25	D..10B025	134,00	126,66	12	0,82	16	2,17	16	3,53
26	D..10B026	139,00	131,70	16	0,88	20	2,33	20	3,81
27	D..10B027	144,00	136,75	16	0,95	20	2,53	20	4,13
28	D..10B028	148,70	141,78	16	1,03	20	2,74	20	4,47
29	D..10B029	153,80	146,83	16	1,11	20	2,96	20	4,83
30	D..10B030	158,80	151,87	16	1,19	20	3,18	20	5,20
31	D..10B031	163,80	156,92	16	1,28	20	3,41	20	5,50
32	D..10B032	168,90	161,95	16	1,36	20	3,66	20	5,97
33	D..10B033	174,50	167,00	16	1,45	20	3,90	20	6,38
34	D..10B034	179,00	172,05	16	1,55	20	4,16	20	6,80
35	D..10B035	184,10	177,10	16	1,64	20	4,42	20	7,23
36	D..10B036	189,10	182,15	20	1,73	20	4,70	25	7,62
37	D..10B037	194,20	187,20	20	1,83	20	4,98	25	8,08
38	D..10B038	199,20	192,24	20	1,94	20	5,26	25	8,55
39	D..10B039	204,20	197,29	20	2,05	20	5,56	25	9,04
40	D..10B040	209,30	202,34	20	2,16	20	5,87	25	9,54
41	D..10B041	214,80	207,39	20	2,29	20	6,05	25	10,05
42	D..10B042	219,90	212,44	20	2,39	25	6,46	25	10,58
43	D..10B043	224,90	217,49	20	2,50	25	6,80	25	11,00

Z	Art. Nr.	de	dp	EINFACH		ZWEIFACH		DREIFACH	
				D1	Kg	D2	Kg	D3	Kg
44	D..10B044	230,00	222,53	20	2,63	25	7,13	25	11,67
45	D..10B045	235,00	227,58	20	2,75	25	7,47	25	12,24
46	D..10B046	240,10	232,63	20	2,88	25	7,83	25	12,82
47	D..10B047	245,10	237,68	20	3,01	25	8,19	25	13,42
48	D..10B048	250,20	242,73	20	3,14	25	8,55	25	14,01
49	D..10B049	255,20	247,78	20	3,28	25	8,94	25	14,64
50	D..10B050	260,30	252,82	20	3,42	25	9,32	25	15,26
51	D..10B051	265,30	257,87	20	3,56	25	9,71	25	15,90
52	D..10B052	270,40	262,92	20	3,70	25	10,11	25	16,57
53	D..10B053	275,40	267,97	20	3,85	25	10,52	25	17,10
54	D..10B054	280,50	273,03	20	4,00	25	10,94	25	17,42
55	D..10B055	285,50	278,08	20	4,15	25	11,36	25	18,62
56	D..10B056	290,60	283,13	25	4,30	25	11,80	25	18,73
57	D..10B057	296,00	288,18	25	4,46	25	12,24	25	20,06
58	D..10B058	300,70	293,23	25	4,62	25	12,68	25	20,61
60	D..10B060	310,80	303,32	25	4,95	25	13,61	25	22,31
62	D..10B062	321,40	313,43	25	5,30	25	14,56	30	22,94
64	D..10B064	331,50	323,53	25	5,65	25	14,62	30	25,43
65	D..10B065	336,50	328,58	25	5,83	25	16,05	30	26,26
66	D..10B066	340,60	333,63	25	5,42	25	16,57	30	26,60
68	D..10B068	350,70	343,74	25	6,40	25	17,64	30	27,20
70	D..10B070	361,80	353,84	25	6,79	25	18,70	30	30,61
72	D..10B072	371,90	363,95	25	7,19	25	19,81	30	32,10
75	D..10B075	387,10	379,09	25	7,81	25	21,54	30	35,00
76	D..10B076	392,10	384,16	25	8,02	25	22,14	30	36,27
78	D..10B078	402,20	394,25	25	8,46	25	22,27	30	39,94
80	D..10B080	412,30	404,35	25	8,91	25	24,60	30	40,30
85	D..10B085	437,60	429,62	30	10,06	30	28,00	30	42,50
90	D..10B090	462,80	454,88	30	11,30	30	31,25	30	51,32
95	D..10B095	488,50	480,14	30	12,61	30	34,90	30	57,32
100	D..10B100	513,40	505,40	30	13,99	30	38,75	30	60,00
110	D..10B110	563,90	555,92	30	17,00	30	40,00	30	77,10
114	D..10B114	584,10	576,13	30	19,99	30	50,60	30	83,15
120	D..10B120	614,80	606,44	30	22,17	30	56,16	30	91,00
125	D..10B125	639,70	631,71	30	24,08	30	61,00	30	100,29

.. 1 für einfach; 2 für zweifach; 3 für dreifach.

VORGEBOHRTE KETTENRADSCHLEIBEN 12B

B1 5,3 **B2** 15,4 **B3** 49,8 **b1** 10,8

TEILUNG: 3/4" x 7/16"
TEILUNG: 19,05 x 11,68 mm
MATERIAL: Stahl

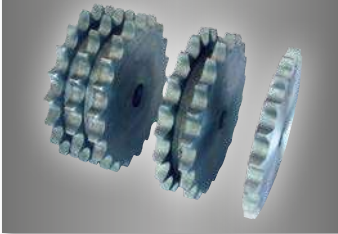

Kettenradschleiben für Einfach-, Zweifach- und Dreifachrollenkettens laut folgenden Normen: DIN 8187 - ISO 606.

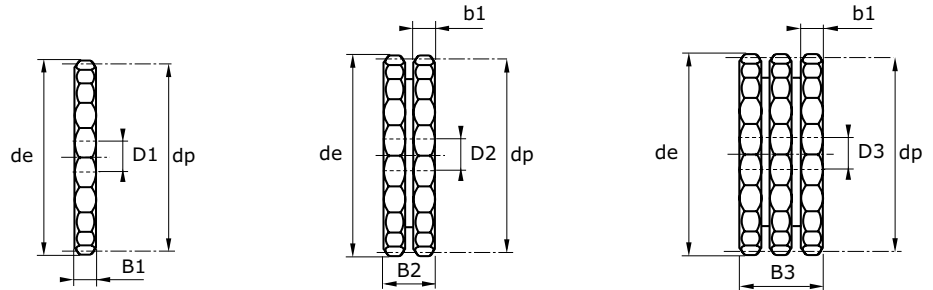

Abmessungen in mm

Z	Art. Nr.	de	dp	EINFACH		ZWEIFACH		DREIFACH	
				D1	Kg	D2	Kg	D3	Kg
8	D..12B008	57,60	49,78	10	0,12	12	0,26	12	0,30
9	D..12B009	62,00	55,70	10	0,15	12	0,33	12	0,57
10	D..12B010	69,00	61,64	10	0,20	12	0,48	12	0,75
11	D..12B011	75,00	67,61	12	0,24	12	0,59	16	0,91
12	D..12B012	81,50	73,60	14	0,30	14	0,72	16	1,13
13	D..12B013	87,50	79,59	14	0,35	14	0,88	16	1,38
14	D..12B014	93,60	85,61	14	0,41	16	1,02	16	1,64
15	D..12B015	99,80	91,63	14	0,48	16	1,20	16	1,93
16	D..12B016	105,50	97,65	14	0,55	16	1,39	20	2,20
17	D..12B017	111,50	103,67	14	0,63	16	1,60	20	2,54
18	D..12B018	118,00	109,71	14	0,71	16	1,81	20	2,89
19	D..12B019	124,20	115,75	14	0,80	16	2,05	20	3,27
20	D..12B020	129,70	121,78	14	0,89	16	2,30	20	3,67
21	D..12B021	136,00	127,82	16	0,99	16	2,53	20	4,10
22	D..12B022	141,80	133,86	16	1,03	20	2,80	20	4,55
23	D..12B023	149,00	139,90	16	1,20	20	3,09	20	5,02
24	D..12B024	153,90	145,94	16	1,31	20	3,39	20	5,51
25	D..12B025	160,00	152,00	16	1,43	20	3,70	20	6,02
26	D..12B026	165,90	158,04	16	1,56	20	4,03	20	6,56
27	D..12B027	172,30	164,09	16	1,68	20	4,38	20	7,12
28	D..12B028	178,00	170,13	16	1,82	20	4,73	20	7,71
29	D..12B029	184,10	176,19	16	1,96	20	5,10	20	8,31
30	D..12B030	190,50	182,25	16	2,10	20	5,49	20	8,97
31	D..12B031	196,30	188,31	20	2,24	20	5,88	25	9,52
32	D..12B032	202,30	194,35	20	2,39	20	6,30	25	10,19
33	D..12B033	209,30	200,40	20	2,55	20	6,72	25	10,89
34	D..12B034	214,60	206,46	20	2,71	20	7,16	25	11,61
35	D..12B035	221,00	212,52	20	2,88	20	7,61	25	12,35
36	D..12B036	226,80	218,58	20	3,06	25	7,99	25	13,11
37	D..12B037	232,90	224,64	20	3,24	25	8,47	25	13,90
38	D..12B038	239,00	230,69	20	3,42	25	8,96	25	14,70
39	D..12B039	245,10	236,75	20	3,61	25	9,50	25	15,54
40	D..12B040	251,30	242,81	20	3,80	25	9,99	25	16,40
41	D..12B041	257,30	248,87	25	3,98	25	10,51	25	17,11
42	D..12B042	264,50	254,93	25	4,19	25	11,07	25	18,17

Z	Art. Nr.	de	dp	EINFACH		ZWEIFACH		DREIFACH	
				D1	Kg	D2	Kg	D3	Kg
43	D..12B043	270,50	260,98	25	4,38	25	11,63	25	19,09
44	D..12B044	276,50	267,03	25	4,61	25	12,21	25	20,03
45	D..12B045	282,50	273,10	25	4,83	25	12,80	25	21,00
46	D..12B046	287,90	279,16	25	5,05	25	13,40	25	21,47
47	D..12B047	294,00	285,21	25	5,28	25	14,02	25	23,00
48	D..12B048	300,10	291,27	25	5,52	25	14,65	25	24,04
49	D..12B049	306,20	297,33	25	5,76	25	15,30	25	24,60
50	D..12B050	312,30	303,39	25	6,00	25	15,95	25	26,17
51	D..12B051	318,40	309,45	25	6,25	25	16,20	25	26,52
52	D..12B052	324,50	315,50	25	6,50	25	17,31	25	28,40
53	D..12B053	330,50	321,56	25	6,77	25	17,50	25	28,53
54	D..12B054	336,60	327,67	25	7,03	25	18,73	25	30,72
55	D..12B055	342,70	333,70	25	7,30	25	19,45	25	31,91
56	D..12B056	348,70	339,75	25	7,57	25	20,20	30	32,07
57	D..12B057	355,40	345,81	25	7,85	25	20,95	30	34,28
58	D..12B058	361,50	351,87	25	8,13	25	21,72	30	35,00
60	D..12B060	373,00	363,99	25	8,72	25	23,30	30	38,12
62	D..12B062	385,10	376,12	25	9,33	30	24,50	30	39,26
64	D..12B064	397,20	388,24	25	9,95	30	26,62	30	40,53
65	D..12B065	403,20	394,29	25	10,27	30	27,48	30	45,00
68	D..12B068	421,40	412,49	30	11,24	30	28,24	30	46,56
70	D..12B070	433,60	424,60	30	11,92	30	32,01	30	52,42
72	D..12B072	447,00	436,74	30	12,63	30	33,92	30	55,55
75	D..12B075	463,90	454,91	30	13,72	30	36,88	30	57,30
76	D..12B076	469,90	460,99	30	14,09	30	37,90	30	62,09
78	D..12B078	482,10	473,10	30	14,86	30	38,00	30	63,63
80	D..12B080	494,20	485,22	30	15,65	30	42,10	30	68,98
85	D..12B085	524,50	515,55	30	17,70	30	47,66	30	78,10
90	D..12B090	554,80	545,86	30	19,87	30	53,36	30	87,10
95	D..12B095	585,10	576,17	30	22,18	30	59,80	30	98,04
100	D..12B100	615,40	606,47	30	24,60	30	66,39	30	108,86
110	D..12B110	676,10	667,11	30	29,84	30	79,00	30	130,00
114	D..12B114	700,60	691,36	30	32,07	30	86,68	30	142,15
120	D..12B120	736,70	727,74	30	35,58	30	94,00	30	157,77
125	D..12B125	767,00	758,05	30	38,63	30	104,50	30	171,41

.. 1 für einfach; 2 für zweifach; 3 für dreifach.

VORGEBOHRTE KETTENRADSCHLEIBEN 16B

B1 16,2 B2 47,7 B3 79,6 b1 15,8

TEILUNG: 1" x 17,02 mm
TEILUNG: 25,4 x 17,02 mm
MATERIAL: Stahl

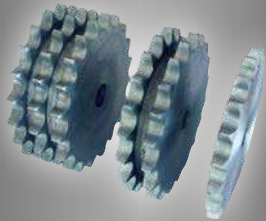

Kettenradschleiben für Einfach-, Zweifach- und Dreifachrollenkettens laut folgenden Normen: DIN 8187 - ISO 606.

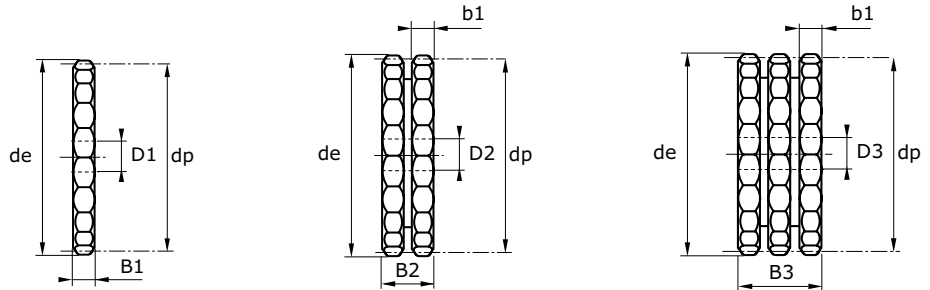

Abmessungen in mm

Z	Art. Nr.	de	dp	EINFACH		ZWEIFACH		DREIFACH	
				D1	Kg	D2	Kg	D3	Kg
8	D..16B008	77,00	66,37	16	0,30	16	0,71	16	1,13
9	D..16B009	85,00	74,27	16	0,39	16	0,97	16	1,56
10	D..16B010	93,00	82,19	16	0,51	16	1,27	16	2,05
11	D..16B011	99,50	90,14	16	0,63	20	1,57	20	2,53
12	D..16B012	109,00	98,14	16	0,77	20	1,94	20	3,15
13	D..16B013	117,00	106,12	16	0,92	20	2,36	20	3,84
14	D..16B014	125,00	114,15	16	1,08	20	2,81	20	4,59
15	D..16B015	133,00	122,17	16	1,26	20	3,31	20	5,40
16	D..16B016	141,00	130,20	20	1,43	20	3,84	25	6,16
17	D..16B017	149,00	138,22	20	1,64	20	4,41	25	7,11
18	D..16B018	157,00	146,28	20	1,85	20	5,01	25	8,11
19	D..16B019	165,20	154,33	20	2,08	20	5,66	25	9,18
20	D..16B020	173,20	162,38	20	2,32	20	6,34	25	10,31
21	D..16B021	181,20	170,43	20	2,58	25	7,00	25	11,51
22	D..16B022	189,30	178,48	20	2,84	25	7,76	25	12,77
23	D..16B023	197,50	186,53	20	3,13	25	8,56	25	14,10
24	D..16B024	205,50	194,59	20	3,42	25	9,40	25	14,49
25	D..16B025	213,50	202,66	20	3,73	25	10,28	25	16,94
26	D..16B026	221,60	210,72	20	4,05	25	11,20	30	18,33
27	D..16B027	229,60	218,79	20	4,38	25	12,15	30	19,91
28	D..16B028	237,70	226,85	20	4,73	25	13,14	30	21,55
29	D..16B029	245,80	234,92	20	5,09	25	14,17	30	23,26
30	D..16B030	254,00	243,00	20	5,46	25	15,24	30	25,04
31	D..16B031	262,00	251,08	25	5,82	25	16,35	30	26,88
32	D..16B032	270,00	259,13	25	6,22	25	17,50	30	28,78
33	D..16B033	278,50	267,21	25	6,63	25	18,68	30	30,75
34	D..16B034	287,00	275,28	25	7,06	25	19,90	30	32,78
35	D..16B035	296,20	283,36	25	7,50	25	21,16	30	34,88
36	D..16B036	304,60	291,44	25	7,95	25	22,46	30	37,04
37	D..16B037	312,60	299,51	25	8,41	25	23,80	30	41,00
38	D..16B038	320,70	307,59	25	8,88	25	25,18	30	41,56
39	D..16B039	328,80	315,67	25	9,37	25	26,59	30	42,10
40	D..16B040	336,90	323,73	25	9,88	25	28,04	30	46,42
41	D..16B041	345,00	331,82	25	10,39	25	27,88	30	46,63
42	D..16B042	353,00	339,90	25	10,92	25	31,07	30	51,34

Z	Art. Nr.	de	dp	EINFACH		ZWEIFACH		DREIFACH	
				D1	Kg	D2	Kg	D3	Kg
43	D..16B043	361,10	347,98	25	11,46	25	31,90	30	56,00
44	D..16B044	369,10	356,06	25	12,02	25	34,24	30	56,63
45	D..16B045	377,10	364,12	25	12,60	25	35,89	30	59,36
46	D..16B046	385,20	372,21	25	13,17	25	37,56	30	62,17
47	D..16B047	393,20	380,29	25	13,76	25	37,80	30	62,80
48	D..16B048	401,30	388,36	25	14,37	25	41,06	30	67,97
49	D..16B049	409,30	396,44	25	14,99	25	42,36	30	68,40
50	D..16B050	417,40	404,52	25	15,63	25	44,70	30	74,01
51	D..16B051	425,50	412,60	30	16,25	30	44,37	40	74,98
52	D..16B052	433,60	420,67	30	16,90	30	48,40	40	79,98
53	D..16B053	441,70	428,75	30	17,58	30	49,89	40	81,00
54	D..16B054	448,30	436,85	30	18,26	30	52,13	40	82,55
55	D..16B055	457,90	444,93	30	18,96	30	54,38	40	89,92
56	D..16B056	466,00	453,01	30	19,67	40	56,24	40	90,62
57	D..16B057	474,00	461,07	30	20,50	40	58,35	40	96,87
58	D..16B058	482,10	469,16	30	21,13	40	61,62	40	97,68
60	D..16B060	498,30	485,32	30	22,65	40	64,90	40	107,78
62	D..16B062	514,50	501,50	30	24,22	40	69,46	40	109,53
64	D..16B064	530,70	517,65	30	25,84	40	70,20	40	113,06
65	D..16B065	538,80	525,73	30	26,67	40	76,59	40	127,24
68	D..16B068	562,90	549,98	30	29,23	40	84,07	40	138,00
70	D..16B070	579,20	566,14	30	31,01	40	89,24	40	148,31
72	D..16B072	595,40	582,32	30	32,84	40	94,60	40	157,18
75	D..16B075	619,70	606,55	30	35,68	40	102,85	40	166,44
76	D..16B076	627,00	614,65	30	36,65	40	105,69	40	175,70
78	D..16B078	643,30	630,80	30	38,34	40	107,76	40	185,47
80	D..16B080	660,00	646,96	30	40,68	40	117,43	40	195,25
85	D..16B085	699,90	687,40	30	46,00	40	132,96	40	221,13
90	D..16B090	740,30	727,81	30	51,65	40	149,46	40	248,61
95	D..16B095	781,10	768,22	30	57,62	40	166,91	40	277,70
100	D..16B100	821,10	808,63	30	63,62	40	181,33	40	284,00
110	D..16B110	902,00	889,48	30	77,50	40	220,00	40	370,00
114	D..16B114	934,30	921,81	30	83,31	40	242,01	40	402,85
120	D..16B120	982,80	970,33	30	92,40	40	250,00	40	425,00
125	D..16B125	1023,20	1010,73	30	100,33	40	291,84	40	485,90

.. 1 für einfach; 2 für zweifach; 3 für dreifach.

VORGEBOHRTE KETTENRADSCHLEIBEN 20B

B1	B2	B3	b1
5,3	15,4	91	18,2

TEILUNG: 1 1/4 x 3/4"
 TEILUNG: 31,75 x 19,56 mm
 MATERIAL: Stahl

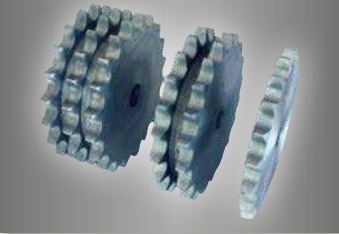

Kettenradschleiben für Einfach-, Zweifach- und Dreifachrollenkettens laut folgenden Normen: DIN 8187 - ISO 606.

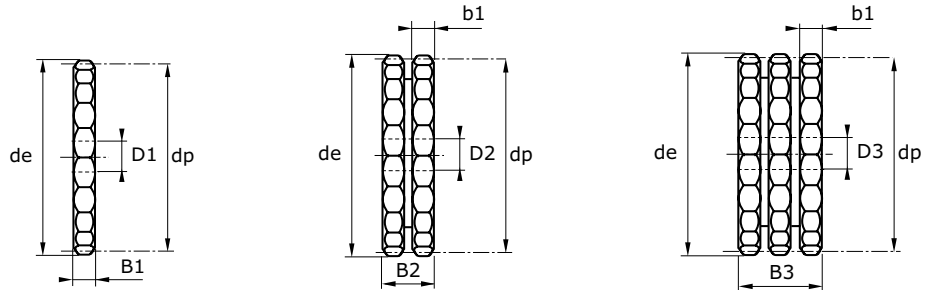

Abmessungen in mm

Z	Art. Nr.	de	dp	EINFACH		ZWEIFACH		DREIFACH	
				D1	Kg	D2	Kg	D3	Kg
8	D..20B008	98,10	82,96	16	0,55	20	1,28	20	2,02
9	D..20B009	108,00	92,84	16	0,73	20	1,74	20	2,79
10	D..20B010	117,90	102,74	16	0,93	20	2,28	20	3,77
11	D..20B011	127,80	112,68	20	1,13	20	2,89	25	4,53
12	D..20B012	137,80	122,68	20	1,38	20	3,56	25	5,64
13	D..20B013	147,80	132,65	20	1,65	20	4,31	25	4,87
14	D..20B014	157,80	142,68	20	1,94	20	5,12	25	8,20
15	D..20B015	167,90	152,72	20	1,96	20	6,00	25	9,65
16	D..20B016	177,90	162,75	20	2,60	30	6,78	30	11,07
17	D..20B017	187,90	172,78	20	2,96	30	7,80	30	12,75
18	D..20B018	198,00	182,85	20	3,34	30	8,89	30	14,54
19	D..20B019	208,10	192,91	20	3,75	30	10,05	30	16,45
20	D..20B020	218,10	202,98	20	4,19	30	11,27	30	18,47
21	D..20B021	228,20	213,04	25	4,62	30	12,56	30	20,62
22	D..20B022	238,30	223,11	25	5,09	30	13,93	30	22,87
23	D..20B023	248,30	233,17	25	5,60	30	15,36	30	25,24
24	D..20B024	258,40	243,23	25	6,18	30	16,86	30	27,72
25	D..20B025	268,50	253,33	25	6,67	30	18,43	30	30,32
26	D..20B026	278,60	263,40	30	7,21	30	20,07	30	33,03
27	D..20B027	288,60	273,48	30	7,81	30	21,17	30	35,86
28	D..20B028	298,70	283,56	30	8,43	30	23,56	30	38,80
29	D..20B029	308,80	293,65	30	9,07	30	25,39	30	43,50
30	D..20B030	318,90	303,75	30	9,73	30	27,30	30	45,03
31	D..20B031	329,00	313,85	30	10,42	30	29,29	30	49,60
32	D..20B032	339,10	323,91	30	11,13	30	31,34	30	51,72
33	D..20B033	349,20	334,01	30	11,87	30	34,55	30	56,71
34	D..20B034	359,30	344,10	30	12,63	30	35,64	30	58,86
35	D..20B035	369,20	354,20	30	13,41	30	37,90	30	62,60
36	D..20B036	379,50	364,30	30	14,22	30	40,22	30	66,46
37	D..20B037	389,50	374,39	30	15,04	30	43,78	30	72,98
38	D..20B038	399,40	384,49	30	15,90	30	45,08	30	74,52

.. 1 für einfach; 2 für zweifach; 3 für dreifach.

Z	Art. Nr.	de	dp	EINFACH		ZWEIFACH		DREIFACH	
				D1	Kg	D2	Kg	D3	Kg
39	D..20B039	409,70	394,59	30	16,77	30	48,75	30	81,07
40	D..20B040	419,80	404,66	30	17,67	30	50,21	30	83,04
41	D..20B041	429,90	414,78	30	18,59	30	53,81	40	90,20
42	D..20B042	440,00	424,88	30	19,54	30	55,62	40	102,66
43	D..20B043	450,10	434,97	30	20,50	30	60,00	40	105,11
44	D..20B044	460,20	445,07	30	21,50	30	61,30	40	107,55
45	D..20B045	470,30	455,17	30	22,51	30	64,25	40	105,96
46	D..20B046	480,40	465,26	30	23,55	30	67,26	40	112,44
47	D..20B047	490,50	475,36	30	23,50	30	71,52	40	115,00
48	D..20B048	500,60	485,46	30	25,00	30	76,50	40	117,33
49	D..20B049	510,70	495,55	30	25,57	30	78,10	40	119,36
51	D..20B051	530,90	515,75	30	27,54	30	84,67	40	138,72
52	D..20B052	541,00	525,84	30	29,50	40	90,00	40	141,44
53	D..20B053	551,10	535,94	30	30,60	40	91,74	40	144,16
54	D..20B054	561,20	546,07	30	32,69	40	93,46	40	146,88
55	D..20B055	571,30	556,16	30	33,94	40	95,20	40	161,16
56	D..20B056	581,40	566,26	30	35,21	40	96,90	40	152,32
57	D..20B057	591,50	576,36	30	36,51	40	104,71	40	173,58
58	D..20B058	601,60	586,45	30	37,82	40	108,87	40	181,12
60	D..20B060	621,80	606,65	30	40,53	40	116,43	40	193,06
64	D..20B064	662,20	647,06	30	46,22	40	127,00	40	211,00
65	D..20B065	672,30	657,16	30	47,70	40	137,34	40	227,83
70	D..20B070	722,80	707,67	30	55,45	40	159,97	40	265,46
75	D..20B075	773,30	758,19	30	63,79	40	176,80	40	289,30
76	D..20B076	793,50	768,32	30	66,53	40	189,39	40	314,39
80	D..20B080	823,90	808,72	30	72,71	40	210,38	40	350,00
85	D..20B085	874,40	859,25	30	82,21	40	223,13	40	371,87
90	D..20B090	924,90	909,76	30	92,30	40	235,52	40	418,35
95	D..20B095	975,20	960,28	30	102,96	40	298,90	40	500,00
100	D..20B100	1026,00	1010,79	40	114,13	40	315,80	40	526,31
114	D..20B114	1167,40	1152,26	40	148,73	40	433,24	40	720,16

VORGEBOHRTE KETTENRADSCHLEIBEN 24B

B1 5,3 **B2** 15,4 **B3** 120,3 **b1** 23,6

TEILUNG: 1 1/2 x 1
TEILUNG: 38,10 x 25,4 mm
MATERIAL: Stahl

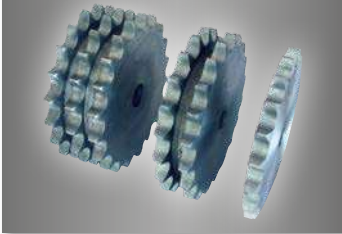

Kettenradschleiben für Einfach-, Zweifach- und Dreifachrollenkettens laut folgenden Normen: DIN 8187 - ISO 606.

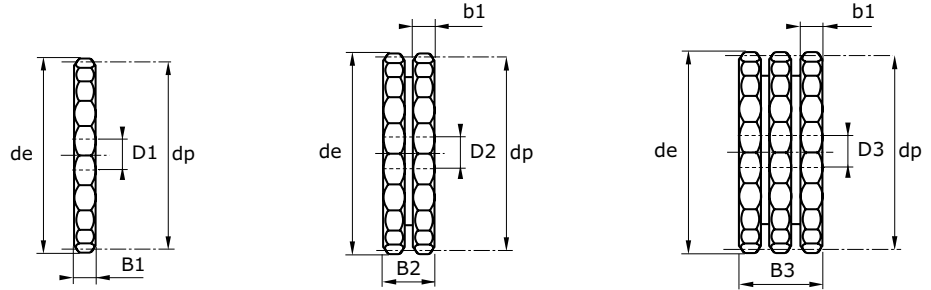

Abmessungen in mm

Z	Art. Nr.	de	dp	EINFACH		ZWEIFACH		DREIFACH	
				D1	Kg	D2	kg	D3	Kg
8	D..24B008	115,00	99,55	20	1,00	25	2,31	25	3,67
9	D..24B009	126,40	111,40	20	1,32	25	3,18	25	5,10
10	D..24B010	138,00	123,29	20	1,69	25	4,19	25	6,75
11	D..24B011	150,00	135,21	25	2,07	25	5,33	30	8,42
12	D..24B012	162,00	147,22	25	2,53	25	6,59	30	10,50
13	D..24B013	174,20	159,18	25	3,03	25	7,99	30	12,81
14	D..24B014	186,20	171,22	25	3,57	25	9,52	30	15,33
15	D..24B015	198,20	183,26	25	4,16	25	11,18	30	18,08
16	D..24B016	210,30	195,30	25	4,79	30	12,85	30	21,04
17	D..24B017	222,30	207,34	25	5,47	30	14,77	30	24,22
18	D..24B018	234,30	219,42	25	6,19	30	16,82	30	27,61
19	D..24B019	246,50	231,49	25	6,95	30	19,00	30	31,23
20	D..24B020	258,50	243,57	25	7,76	30	21,31	30	35,06
21	D..24B021	270,50	255,65	30	8,57	30	23,75	40	38,60
22	D..24B022	282,70	267,73	30	9,46	30	26,33	40	42,87
23	D..24B023	294,80	279,80	30	10,40	30	29,03	40	47,36
24	D..24B024	306,80	291,88	30	11,38	30	31,86	40	52,07
25	D..24B025	319,00	304,00	30	12,41	30	34,83	40	56,99
26	D..24B026	331,00	316,08	30	13,47	30	37,93	40	62,14
27	D..24B027	343,20	328,19	30	14,59	30	41,15	40	67,50
28	D..24B028	355,20	340,27	30	15,74	30	44,51	40	73,08
29	D..24B029	367,30	352,38	30	16,94	30	48,00	40	78,99
30	D..24B030	379,50	364,50	30	18,91	30	51,61	40	84,90
31	D..24B031	391,60	376,62	30	19,47	40	55,05	40	91,24
32	D..24B032	403,70	388,69	30	20,80	40	58,93	40	97,59
33	D..24B033	415,80	400,81	30	22,18	40	62,94	40	102,75
34	D..24B034	427,80	412,93	30	23,60	40	67,08	40	107,93
35	D..24B035	440,00	425,04	30	25,06	40	71,35	40	118,26
36	D..24B036	452,00	437,16	30	26,60	40	75,75	40	123,72
37	D..24B037	464,20	449,27	30	28,12	40	80,28	40	129,17
38	D..24B038	476,20	461,39	30	29,71	40	84,95	40	140,08
39	D..24B039	488,50	473,50	30	30,25	40	85,70	40	145,10

Z	Art. Nr.	de	dp	EINFACH		ZWEIFACH		DREIFACH	
				D1	Kg	D2	kg	D3	Kg
40	D..24B040	500,60	485,62	30	33,03	40	94,66	40	158,08
41	D..24B041	512,60	497,74	30	34,75	40	99,78	40	168,91
42	D..24B042	524,70	509,85	30	36,52	40	104,90	40	179,73
43	D..24B043	536,80	521,97	30	35,50	40	109,70	40	185,60
44	D..24B044	549,00	534,08	30	36,84	40	115,20	40	196,20
45	D..24B045	561,20	546,20	30	42,08	40	121,24	40	201,37
46	D..24B046	573,30	558,32	30	44,03	40	124,00	40	208,67
47	D..24B047	585,40	570,43	30	41,38	40	131,37	40	215,96
48	D..24B048	597,40	582,55	30	48,04	40	138,75	40	230,56
50	D..24B050	621,70	606,78	30	52,24	40	151,08	40	251,11
51	D..24B051	633,80	618,89	30	51,51	-	-	-	-
52	D..24B052	646,00	631,01	30	54,00	-	-	-	-
53	D..24B053	658,00	643,13	30	55,10	-	-	-	-
54	D..24B054	670,20	655,25	30	61,14	-	-	-	-
55	D..24B055	682,30	667,40	30	63,48	-	-	-	-
56	D..24B056	694,40	679,50	30	65,86	-	-	-	-
57	D..24B057	706,55	691,63	30	68,28	40	198,34	40	329,92
58	D..24B058	718,60	703,74	30	66,14	-	-	-	-
59	D..24B059	730,70	715,86	30	67,30	-	-	-	-
60	D..24B060	742,80	727,97	30	75,82	40	220,55	40	366,97
62	D..24B062	767,20	752,24	40	80,95	-	-	-	-
64	D..24B064	791,30	776,48	40	76,80	-	-	-	-
65	D..24B065	803,40	788,59	40	89,14	40	260,19	40	410,24
66	D..24B066	815,60	800,17	40	86,30	-	-	-	-
68	D..24B068	839,80	824,98	40	95,04	-	-	-	-
70	D..24B070	864,20	849,21	40	103,77	-	-	-	-
72	D..24B072	888,40	873,48	40	100,80	-	-	-	-
75	D..24B075	924,80	909,83	40	105,00	-	-	-	-
76	D..24B076	936,90	921,98	40	122,54	40	358,88	40	597,76
80	D..24B080	985,40	970,44	40	135,99	-	-	-	-
85	D..24B085	1046,00	1031,10	40	153,79	-	-	-	-
95	D..24B095	1167,30	1152,33	40	192,67	-	-	-	-

.. 1 für einfach; 2 für zweifach; 3 für dreifach.

VORGEBOHRTE KETTENRADSCHLEIBEN 28B

B1	B2	B3	b1
5,3	15,4	148	28,8

TEILUNG: 1"3/4 x 1"1/4"
 TEILUNG: 44,45 x 30,99 mm
 MATERIAL: Stahl

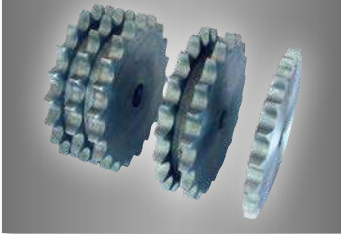

Kettenradschleiben für Einfach-, Zweifach- und Dreifachrollenkettens laut folgenden Normen: DIN 8187 - ISO 606.

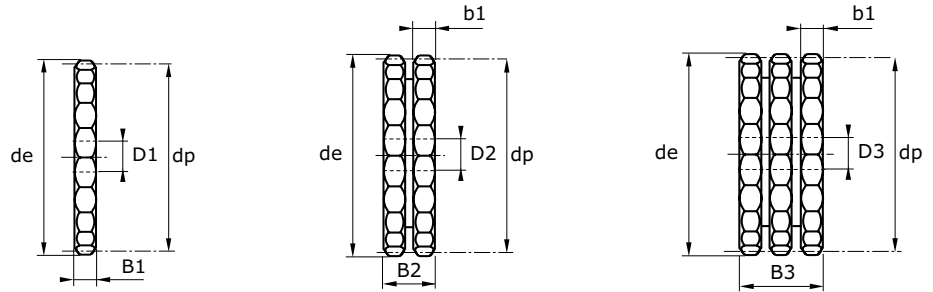

Abmessungen in mm

Z	Art. Nr.	de	dp	EINFACH		ZWEIFACH		DREIFACH	
				D1	Kg	D2	Kg	D3	Kg
8	D..28B008	132,00	116,15	20	1,71	25	4,01	25	6,39
9	D..28B009	148,40	129,96	20	2,26	25	5,48	25	8,80
10	D..28B010	162,30	143,85	20	2,88	25	7,17	25	11,56
11	D..28B011	176,30	157,77	25	3,53	30	8,92	30	14,44
12	D..28B012	189,30	171,74	25	4,29	30	11,04	30	17,93
13	D..28B013	204,20	185,75	25	5,12	30	13,38	30	21,79
14	D..28B014	218,20	199,76	25	6,03	30	15,94	30	26,02
15	D..28B015	232,30	213,79	25	7,01	30	18,72	30	30,61
16	D..28B016	246,30	227,84	30	8,02	30	21,71	30	35,57
17	D..28B017	260,00	241,90	30	9,14	30	24,92	30	40,89
18	D..28B018	274,00	255,98	30	10,34	30	28,36	30	46,58
19	D..28B019	289,00	270,06	30	11,61	30	32,00	30	52,64
20	D..28B020	303,00	284,15	30	12,95	30	35,87	30	59,06
21	D..28B021	317,00	298,24	30	14,37	30	39,96	40	65,20
22	D..28B022	331,00	312,34	30	15,86	30	44,26	40	72,54
23	D..28B023	345,00	326,44	30	17,42	30	48,78	40	79,87
24	D..28B024	359,00	340,55	30	19,05	30	53,64	40	87,93
25	D..28B025	373,00	354,66	30	20,76	30	58,50	40	95,99
26	D..28B026	387,00	368,77	30	22,54	40	63,28	40	107,66
27	D..28B027	401,00	382,88	30	24,39	40	68,78	40	119,35
28	D..28B028	416,00	397,00	30	26,32	40	74,29	40	131,02
29	D..28B029	430,00	411,12	30	26,93	40	80,23	40	136,86
30	D..28B030	444,00	425,24	30	30,38	40	86,17	40	142,70
31	D..28B031	458,00	439,37	30	31,00	40	90,36	40	156,09
32	D..28B032	472,00	453,49	30	34,74	40	94,55	40	169,48
33	D..28B033	486,00	467,62	30	39,70	40	98,74	40	182,87
34	D..28B034	500,00	481,75	30	39,38	40	102,93	40	196,26
35	D..28B035	514,00	495,88	30	41,82	40	119,69	40	209,65
36	D..28B036	529,00	510,01	30	44,32	40	131,05	40	223,04
37	D..28B037	543,00	524,13	30	48,82	40	136,74	40	236,43
38	D..28B038	557,00	538,27	30	49,55	40	142,42	40	236,43
39	D..28B039	571,00	552,40	30	51,31	40	150,55	40	249,98
40	D..28B040	585,00	566,54	30	55,07	40	158,67	40	263,52
45	D..28B045	656,00	637,22	30	70,13	40	203,10	40	337,73
50	D..28B050	726,00	707,91	30	87,01	40	252,99	40	445,25
57	D..28B057	825,00	806,90	40	113,56	40	332,00	40	552,76
60	D..28B060	869,00	849,32	40	126,08	40	466,17	40	776,86
76	D..28B076	1095,00	1075,62	40	203,89	40	600,35	40	1000,97

.. 1 für einfach; 2 für zweifach; 3 für dreifach.



VORGEBOHRTE KETTENRADSCHLEIBEN 32B

B1	B2	B3	b1
5,3	15,4	146	28,8

TEILUNG: 2" x 1"1/4
 TEILUNG: 50,8 x 30,8 mm
 MATERIAL: Stahl

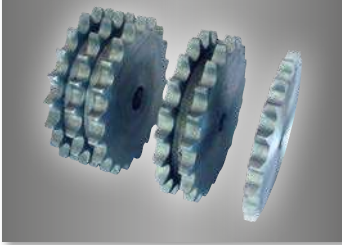

Kettenradschleiben für Einfach-, Zweifach- und Dreifachrollenkettens laut folgenden Normen: DIN 8187 - ISO 606.

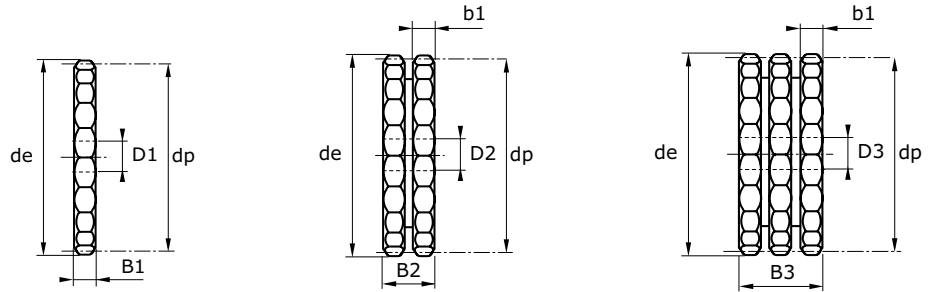

Abmessungen in mm

Z	Art. Nr.	de	dp	EINFACH		ZWEIFACH		DREIFACH	
				D1	Kg	D2	Kg	D3	Kg
8	D..32B008	153,20	132,74	25	2,27	25	5,53	25	8,83
9	D..32B009	169,00	148,54	25	2,99	25	7,46	25	11,99
10	D..32B010	185,00	164,39	25	3,81	25	9,68	25	15,63
11	D..32B011	200,80	180,31	30	4,67	35	11,86	35	19,20
12	D..32B012	216,80	196,29	30	5,67	35	14,64	35	23,78
13	D..32B013	232,80	212,29	30	6,77	35	17,70	35	28,83
14	D..32B014	248,80	228,29	30	7,97	35	21,05	35	34,35
15	D..32B015	264,80	244,30	30	9,26	35	24,68	35	40,34
16	D..32B016	280,90	260,40	30	10,64	40	28,38	40	46,47
17	D..32B017	296,90	276,46	30	12,12	40	32,57	40	53,40
18	D..32B018	313,00	292,55	30	13,69	40	37,05	40	60,80
19	D..32B019	329,10	308,66	30	15,36	40	41,80	40	68,68
20	D..32B020	345,20	324,71	40	16,33	40	46,84	40	77,02
21	D..32B021	361,30	340,82	40	18,85	40	52,15	40	85,84
22	D..32B022	377,50	356,98	40	20,80	40	57,75	40	77,57
23	D..32B023	393,60	373,08	40	22,85	40	63,63	40	104,88
24	D..32B024	409,70	389,18	40	24,99	40	69,80	40	92,87
25	D..32B025	425,80	405,33	40	27,23	40	76,24	40	125,81
26	D..32B026	441,90	421,44	40	29,56	40	82,97	40	111,30
27	D..32B027	458,10	437,69	40	30,12	40	76,33	40	115,56
28	D..32B028	574,20	453,69	40	34,51	40	97,27	40	119,84
29	D..32B029	492,00	469,85	40	34,18	40	87,00	40	124,12
30	D..32B030	506,50	486,00	40	39,84	40	112,70	40	186,37
32	D..32B032	538,80	518,27	40	45,54	40	105,60	40	253,86
35	D..32B035	589,50	566,71	40	54,81	40	156,19	40	258,69
38	D..32B038	635,50	615,16	40	64,93	40	185,67	40	307,73
40	D..32B040	670,50	647,47	40	72,16	40	206,73	40	283,16
45	D..32B045	751,00	728,24	40	91,87	40	265,32	40	438,64
50	D..32B050	831,80	809,04	40	113,96	40	328,95	40	549,27
57	D..32B057	945,00	922,16	40	148,86	40	431,27	40	650,00
60	D..32B060	993,40	970,65	40	165,24	40	450,00	40	780,00
76	D..32B076	1252,00	1229,27	40	267,00	40	757,78	40	1295,64

.. 1 für einfach; 2 für zweifach; 3 für dreifach.

Kettenrad mit einseitiger Nabe für Einfach-, Zweifach- und Dreifachrollenkettens laut folgenden Normen: DIN 8187 - ISO/R 606.

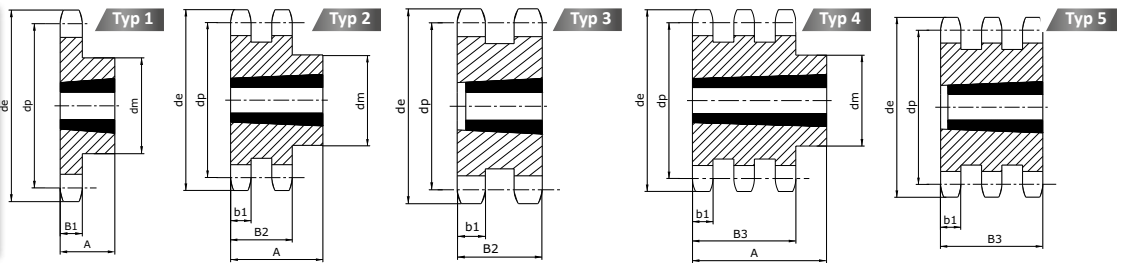

Δ: Ebenso mit einfacher, induktionsgehärteter Zähnung 45/53HRC erhältlich.

Abmessungen in mm

KETTENRÄDER STAHL FÜR KLEMMBUCHSEN 06B

B1	B2	B3	b1
5,3	15,4	25,6	5,2

TEILUNG: 3/8" x 7/32"
TEILUNG: 9,525 x 5,72 mm

Z	Art. Nr.	de	dp	EINFACH					ZWEIFACH					DREIFACH				
				dm*	A*	Buchse	Typ	Kg	dm*	A*	Buchse	Typ	Kg	dm*	A*	Buchse	Typ	Kg
17	P..MA06B017 Δ	55,30	51,83	45	22	1008	1	0,11	42	22	1008	2	0,11	-	25,60	1008	5	0,15
18	P..MA06B018	58,30	54,85	45	22	1008	1	0,14	43	22	1008	2	0,11	-	25,60	1008	5	0,24
19	P..MA06B019 Δ	61,30	57,86	45	22	1008	1	0,15	46	22	1008	2	0,18	-	25,60	1008	5	0,24
20	P..MA06B020	64,30	60,89	46	22	1008	1	0,16	48	22	1008	2	0,20	-	25,60	1008	5	0,34
21	P..MA06B021 Δ	68,00	63,90	46	22	1008	1	0,18	49	22	1008	2	0,21	-	25,60	1008	5	0,34
22	P..MA06B022	71,00	66,93	50	22	1108	1	0,25	52	22	1108	2	0,22	-	25,60	1008	5	0,34
23	P..MA06B023 Δ	73,50	69,95	63	25	1210	1	0,27	59	25	1210	2	0,27	-	25,60	1210	5	0,30
24	P..MA06B024	77,00	72,97	63	25	1210	1	0,30	61	25	1210	2	0,30	-	25,60	1210	5	0,41
25	P..MA06B025 Δ	80,00	76,02	63	25	1210	1	0,32	64	25	1210	2	0,37	-	25,60	1210	5	0,41
26	P..MA06B026	83,00	79,02	63	25	1210	1	0,33	65	25	1210	2	0,40	-	25,60	1210	5	0,55
27	P..MA06B027 Δ	86,00	82,02	63	25	1210	1	0,34	70	25	1210	2	0,50	-	25,60	1210	5	0,55
28	P..MA06B028	89,00	85,07	63	25	1210	1	0,37	70	25	1210	2	0,56	-	-	-	-	-
30	P..MA06B030 Δ	94,70	91,12	63	25	1210	1	0,39	75	25	1210	2	0,68	79	38	1615	4	0,88
38	P..MA06B038	119,50	115,34	70	25	1210	1	0,65	80	25	1610	2	1,03	90	38	1615	4	1,75
45	P..MA06B045	140,70	136,54	70	25	1210	1	1,01	80	25	1610	2	1,10	-	-	-	-	-
57	P..MA06B057	176,90	172,91	70	25	1210	1	1,34	80	25	1610	2	1,16	-	-	-	-	-
76	P..MA06B076	234,90	230,49	70	25	1210	1	1,84	80	25	1610	2	2,19	-	-	-	-	-

KETTENRÄDER STAHL FÜR KLEMMBUCHSEN 08B

B1	B2	B3	b1
7,2	21	34,9	7

TEILUNG: 1/2" x 5/16"
TEILUNG: 12,7 x 7,75 mm

Z	Art. Nr.	de	dp	EINFACH					ZWEIFACH					DREIFACH				
				dm*	A*	Buchse	Typ	Kg	dm*	A*	Buchse	Typ	Kg	dm*	A*	Buchse	Typ	Kg
15	P..MA08B015 Δ	65,50	61,90	45	22	1008	1	0,16	46	22	1008	2	0,22	-	34,90	1008	5	0,36
16	P..MA08B016	69,50	65,10	50	22	1108	1	0,20	50	22	1108	2	0,22	-	34,90	1008	5	0,35
17	P..MA08B017 Δ	73,60	69,11	60	25	1210	1	0,22	56	25	1210	2	0,23	-	34,90	1210	5	0,35
18	P..MA08B018	77,80	73,14	60	25	1210	1	0,27	60	25	1210	2	0,30	-	34,90	1210	5	0,35
19	P..MA08B019 Δ	81,70	77,15	63	25	1210	1	0,33	62	25	1210	2	0,38	62	38	1210	4	0,61
20	P..MA08B020	85,80	81,19	71	25	1610	1	0,27	66	25	1610	2	0,40	-	34,90	1210	5	0,61
21	P..MA08B021 Δ	89,70	85,21	71	25	1610	1	0,36	70	25	1610	2	0,50	70	38	1610	4	0,65
22	P..MA08B022	93,80	89,24	71	25	1610	1	0,36	76	25	1610	2	0,50	-	34,90	1210	5	0,65
23	P..MA08B023 Δ	98,20	93,26	76	25	1610	1	0,50	79	25	1610	2	0,62	70	38	1610	4	0,93
24	P..MA08B024	101,80	97,29	76	25	1610	1	0,53	84	32	2012	2	0,62	-	34,90	1210	5	0,93
25	P..MA08B025 Δ	105,80	101,32	76	25	1610	1	0,56	87	32	2012	2	0,72	-	34,90	2012	5	0,85
26	P..MA08B026	110,00	105,36	76	25	1610	1	0,60	87	32	2012	2	0,90	-	34,90	2012	5	0,85
27	P..MA08B027 Δ	114,40	109,39	76	25	1610	1	0,63	87	32	2012	2	0,92	-	34,90	2012	5	1,18
28	P..MA08B028	118,00	113,42	90	32	2012	1	0,77	87	32	2012	2	1,00	-	34,90	2012	5	1,18
30	P..MA08B030 Δ	126,10	121,49	90	32	2012	1	0,91	87	32	2012	2	1,24	-	34,90	2012	5	1,73
38	P..MA08B038	158,50	153,79	90	32	2012	1	1,23	100	32	2012	2	2,50	-	34,90	2012	5	3,53
45	P..MA08B045	188,00	182,07	100	32	2012	1	1,68	100	32	2012	2	3,55	-	34,90	2012	5	3,53
57	P..MA08B057	236,40	230,54	100	32	2012	1	2,78	100	32	2012	2	3,64	-	34,90	2012	5	3,53
76	P..MA08B076	313,30	307,33	100	32	2012	1	3,81	100	32	2012	2	5,09	-	34,90	2012	5	3,53

.. 1 für einfach; 2 für zweifach; 3 für dreifach.
*Änderungen der Abmessungen vorbehalten, wenden Sie sich bitte im Bedarfsfall an uns

KETTENRÄDER, KETTENRADSCHEBEN UND GUSSRÄDER

MATERIAL: C45

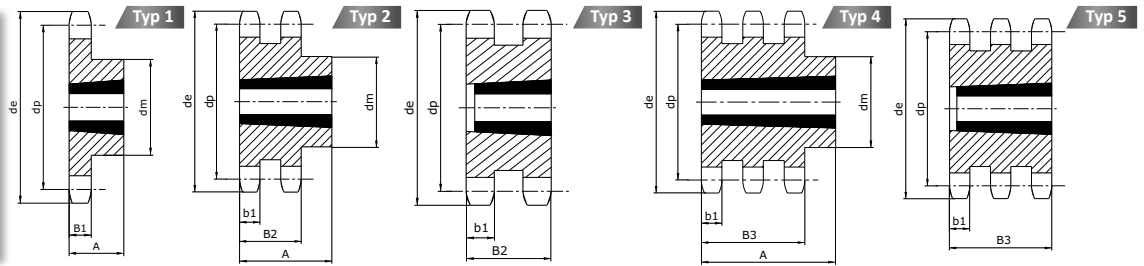

Δ: Ebenso mit einfacher, induktionsgehärteter Zahnung 45/53HRC erhältlich.

Abmessungen in mm

KETTENRÄDER STAHL FÜR KLEMMBUCHSEN 10 B

B1 5,3	B2 15,4	B3 42,1	b1 9
------------------	-------------------	-------------------	----------------

TEILUNG: 5/8" x 3/8"
TEILUNG: 15,875 x 9,65 mm

Z	Art. Nr.	de	dp	EINFACH					ZWEIFACH					DREIFACH				
				dm*	A*	Buchse	Typ	Kg	dm*	A*	Buchse	Typ	Kg	dm*	A*	Buchse	Typ	Kg
13	P..MA10B013 Δ	73,00	66,33	47	22	1008	1	0,23	-	-	-	-	-	-	-	-	-	-
14	P..MA10B014	78,00	71,34	52	22	1108	1	0,27	-	-	-	-	-	-	-	-	-	-
15	P..MA10B015 Δ	83,00	76,35	60	25	1210	1	0,30	-	25,50	1210	3	0,38	-	42,10	1210	5	0,63
16	P..MA10B016	88,00	81,37	70	25	1610	1	0,38	-	-	-	-	-	-	-	-	-	-
17	P..MA10B017 Δ	93,00	86,39	71	25	1610	1	0,38	-	25,50	1610	3	0,47	-	42,10	1210	5	1,01
18	P..MA10B018	98,30	91,42	75	25	1610	1	0,43	-	25,50	1610	3	0,60	-	-	-	-	-
19	P..MA10B019 Δ	103,30	96,44	75	25	1610	1	0,54	-	25,50	1610	3	0,72	-	42,10	1615	5	1,19
20	P..MA10B020	108,40	101,49	75	25	1610	1	0,61	-	25,50	1610	3	0,90	-	-	-	-	-
21	P..MA10B021 Δ	113,40	106,51	76	25	1610	1	0,65	-	25,50	1610	3	1,01	-	42,10	1615	5	1,66
22	P..MA10B022	118,00	111,55	76	25	1610	1	0,72	-	25,50	1610	3	1,20	-	-	-	-	-
23	P..MA10B023 Δ	123,40	116,58	76	25	1610	1	0,77	-	25,50	1610	3	1,35	-	42,10	2012	5	1,78
24	P..MA10B024	128,30	121,62	90	32	1610	1	0,98	90	32	2012	2	1,40	-	-	-	-	-
25	P..MA10B025 Δ	134,00	126,66	90	32	2012	1	1,05	90	32	2012	2	1,55	105	45	2517	4	1,81
26	P..MA10B026	137,00	131,70	90	32	2012	1	1,11	90	32	2012	2	1,80	-	-	-	-	-
27	P..MA10B027 Δ	144,00	136,74	90	32	2012	1	1,17	90	32	2012	2	1,98	110	45	2517	4	2,45
28	P..MA10B028	148,70	141,78	90	32	2012	1	1,29	90	32	2012	2	2,20	-	-	-	-	-
30	P..MA10B030 Δ	158,80	151,87	90	32	2012	1	1,40	90	32	2012	2	2,63	120	45	2517	4	3,54
38	P..MA10B038	199,20	192,24	100	32	2012	1	2,43	108	45	2517	2	4,70	120	45	2717	4	6,90
45	P..MA10B045	235,00	227,58	100	32	2012	1	3,46	-	-	-	-	-	-	-	-	-	-
57	P..MA10B057	296,00	288,18	100	32	2012	1	4,28	-	-	-	-	-	-	-	-	-	-
76	P..MA10B076	392,10	384,16	100	32	2012	1	5,95	-	-	-	-	-	-	-	-	-	-

KETTENRÄDER STAHL FÜR KLEMMBUCHSEN 12 B

B1 5,3	B2 15,4	B3 49,8	b1 10,8
------------------	-------------------	-------------------	-------------------

TEILUNG: 3/4" x 7/16"
TEILUNG: 19,05 x 11,68 mm

Z	Art. Nr.	de	dp	EINFACH					ZWEIFACH					DREIFACH				
				dm*	A*	Buchse	Typ	Kg	dm*	A*	Buchse	Typ	Kg	dm*	A*	Buchse	Typ	Kg
13	P..MA12B013 Δ	87,50	79,60	60	25	1210	1	0,35	-	-	-	-	-	-	-	-	-	-
14	P..MA12B014	93,60	85,61	70	25	1610	1	0,40	-	-	-	-	-	-	-	-	-	-
15	P..MA12B015 Δ	99,80	91,62	70	25	1610	1	0,44	-	30	1610	3	0,78	-	49,80	1615	5	1,11
16	P..MA12B016	105,50	97,65	75	25	1610	1	0,53	-	30	1610	3	0,90	-	-	-	-	-
17	P..MA12B017 Δ	111,50	103,67	76	25	1610	1	0,66	-	30	1610	3	1,24	-	49,80	1615	5	1,75
18	P..MA12B018	118,00	109,71	90	32	2012	1	0,86	90	32	1610	2	1,24	-	-	-	-	-
19	P..MA12B019 Δ	124,20	115,75	90	32	2012	1	0,94	90	32	2012	2	1,24	-	49,80	2012	5	2,02
20	P..MA12B020	129,70	121,78	90	32	2012	1	1,04	108	45	2517	2	1,40	-	-	-	-	-
21	P..MA12B021 Δ	136,00	127,81	102	45	2517	1	1,24	108	45	2517	2	1,68	-	49,80	2517	5	2,09
22	P..MA12B022	141,80	133,86	102	45	2517	1	1,60	108	45	2517	2	2,00	-	-	-	-	-
23	P..MA12B023 Δ	149,00	139,90	108	45	2517	1	1,70	108	45	2517	2	2,24	-	49,80	2517	5	3,00
24	P..MA12B024	154,30	145,94	108	45	2517	1	1,81	108	45	2517	2	2,60	-	-	-	-	-
25	P..MA12B025 Δ	160,00	152,00	108	45	2517	1	1,93	108	45	2517	2	2,87	-	49,80	2517	5	3,98
26	P..MA12B026	165,90	158,04	108	45	2517	1	2,04	108	45	2517	2	3,20	-	-	-	-	-
27	P..MA12B027 Δ	172,30	164,09	108	45	2517	1	2,14	108	45	2517	2	3,55	140	51	3020	4	3,90
28	P..MA12B028	178,00	170,13	108	45	2517	1	2,37	108	45	2517	2	3,90	-	-	-	-	-
30	P..MA12B030 Δ	190,50	182,24	108	45	2517	1	2,60	108	45	2517	2	4,62	140	51	3020	4	5,64
38	P..MA12B038	239,00	230,69	108	45	2517	1	3,93	140	51	3020	2	8,11	140	51	3020	4	11,58
45	P..MA12B045	282,50	273,10	108	45	2517	1	5,52	140	51	3020	2	9,20	140	51	3020	4	12,41
57	P..MA12B057	355,90	345,81	108	45	2517	1	6,48	140	51	3020	2	10,28	140	51	3020	4	13,23
76	P..MA12B076	469,90	460,99	108	45	2517	1	9,71	140	51	3020	2	15,24	140	51	3020	4	16,89

.. 1 für einfach; 2 für zweifach; 3 für dreifach.

*Änderungen der Abmessungen vorbehalten, wenden Sie sich bitte im Bedarfsfall an uns

Kettenrad mit Naben geführt mittels Einfach-, Doppel- und Dreifachrollenkettens laut folgenden Normen: DIN 8187 - ISO/R 606.

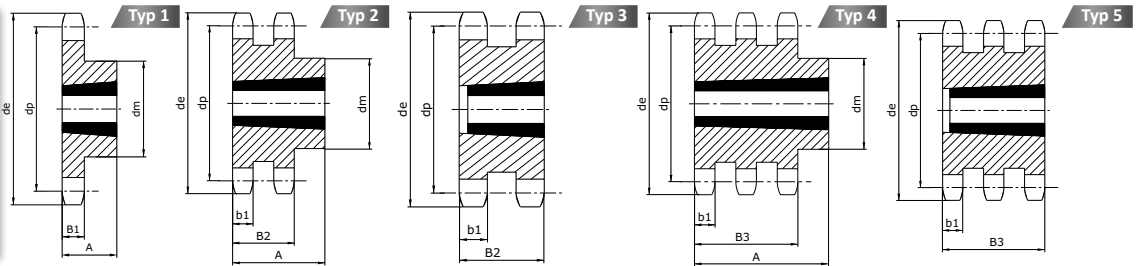

Δ: Ebenso mit einfacher, induktionsgehärteter Zahnung 45/53HRC erhältlich.

Abmessungen in mm

KETTENRÄDER STAHL FÜR KLEMMBUCHSEN 16B

B1	B2	B3	b1
5,3	15,4	79,6	15,8

TEILUNG: 1" x 17,02 mm
TEILUNG: 25,4 x 17,02 mm

Z	Art. Nr.	de	dp	EINFACH					ZWEIFACH					DREIFACH						
				dm*	A*	Buchse	Typ	Kg	dm*	A*	Buchse	Typ	Kg	dm*	A*	Buchse	Typ	Kg		
13	P..MA16B013	117,70	106,13	73	38	1615	1	0,98												
14	P..MA16B014	125,00	114,15	75	38	1615	1	1,14												
15	P..MA16B015 Δ	133,00	122,16	76	38	1615	1	1,30	-	47,70	2012	3	2,11							
16	P..MA16B016	141,00	130,20	90	32	2012	1	1,40		47,70	2517	3	2,25							
17	P..MA16B017 Δ	149,00	138,23	90	32	2012	1	1,59	-	47,70	2517	3	2,53	-	79,60	2517	5	4,29		
18	P..MA16B018	157,00	146,28	108	45	2517	1	2,10		47,70	2517	3	3,11							
19	P..MA16B019 Δ	165,20	154,31	108	45	2517	1	2,29	-	47,70	2517	3	3,80	-	79,60	3030	5	4,36		
20	P..MA16B020	173,20	162,38	108	45	2517	1	2,60		47,70	2517	3	4,00							
21	P..MA16B021 Δ	181,20	170,42	110	45	2517	1	2,81	140	51	3020	2	4,15	-	79,60	3030	5	6,69		
22	P..MA16B022	189,30	178,48	110	45	2517	1	3,10	140	51	3020	2	5,25							
23	P..MA16B023 Δ	197,50	186,53	110	45	2517	1	3,38	140	51	3020	2	5,69	159	89	3535	4	7,80		
24	P..MA16B024	205,50	194,59	110	45	2517	1	3,70	140	51	3020	2	6,00							
25	P..MA16B025 Δ	213,50	202,66	110	45	2517	1	3,97	140	51	3020	2	6,38	175	89	3535	4	10,93		
26	P..MA16B026	221,60	210,72	110	45	2517	1	4,26	140	51	3020	2	8,60							
27	P..MA16B027 Δ	229,60	218,79	110	45	2517	1	4,55	140	51	3020	2	9,27	175	89	3535	4	14,06		
28	P..MA16B028	237,70	226,85	110	45	2517	1	5,26	140	51	3020	2	10,50							
30	P..MA16B030 Δ	254,00	242,99	140	51	3020	1	5,97	140	76	3030	2	13,50	175	89	3535	4	19,10		
38	P..MA16B038	320,70	307,59	140	51	3020	1	8,73	140	76	3030	2	14,94	175	89	3535	5	21,65		
45	P..MA16B045	377,10	364,12	140	51	3020	1	12,49	140	76	3030	7	22,65	215	102	4040	8	32,40		
57	P..MA16B057	474,00	461,07	140	51	3020	1	13,87	175	89	3525	7	25,62	215	102	4040	8	40,50		
76	P..MA16B076	627,00	614,65	140	51	3020	1	22,63	175	89	3535	7	39,00	215	102	4040	8	61,50		

KETTENRÄDER STAHL FÜR KLEMMBUCHSEN 20B

B1	B2	B3	b1
5,3	15,4	91	18,2

TEILUNG: 1 1/4" x 3 3/4"
TEILUNG: 31,75 x 19,56 mm

Z	Art. Nr.	de	dp	EINFACH					ZWEIFACH					DREIFACH							
				dm*	A*	Buchse	Typ	Kg	dm*	A*	Buchse	Typ	Kg	dm*	A*	Buchse	Typ	Kg			
12	P..MA20B012	137,0	122,68	90	32	1615	1	1,90													
13	P..MA20B013	147,5	132,65	90	32	2012	1	1,50		54,6	2517	3	2,20								
14	P..MA20B014	157,6	142,68	110	44	2517	1	2,40													
15	P..MA20B015	167,90	152,72	110	44	2517	1	3,39		54,6	2517	3	4,00		91	3020	5	13,00			
16	P..MA20B016	177,7	162,75	110	44	2517	1	4,23													
17	P..MA20B017	187,90	172,78	110	44	2517	1	5,07		54,6	2517	3	5,00		91	3030	5	15,00			
18	P..MA20B018	197,8	182,85	110	44	2517	1	5,91													
19	P..MA20B019	208,10	192,91	110	44	2517	1	6,75	140	76	3030	2	6,30		91	3030	5	17,00			
20	P..MA20B020	217,9	202,98	110	44	2517	1	7,23													
21	P..MA20B021	228,20	213,04	120	44	2517	1	7,70	140	76	3030	2	8,80		91	3535	5	19,00			
23	P..MA20B023	248,30	233,17	120	44	2517	1	8,78	140	76	3030	2	9,80		91	3535	5	23,00			
25	P..MA20B025	268,50	253,33	120	44	2517	1	9,50	140	76	3030	2	10,50		91	3535	5	28,00			
30	P..MA20B030	318,90	303,65	160	51	3020	1	11,90	160	76	3030	2	14,00		91	3535	5	40,00			
38	P..MA20B038	399,60	384,49	160	51	3020	6	15,80	160	76	3030	7	22,00	178	91	3535	8	35,00			

.. 1 für einfach; 2 für zweifach; 3 für dreifach.

*Änderungen der Abmessungen vorbehalten, wenden Sie sich bitte im Bedarfsfall an uns

Kettenrad mit einseitiger Nabe für Einfach-, Zweifach- und Dreifachrollenkettens laut folgenden Normen: DIN 8187 - ISO/R 606.



Δ: Ebenso mit einfacher, induktionsgehärteter Zahnung 45/53HRC erhältlich.

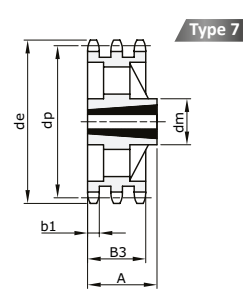
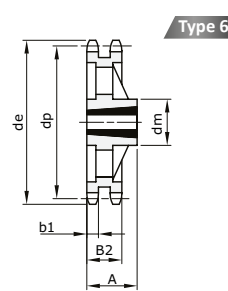
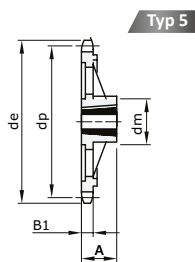
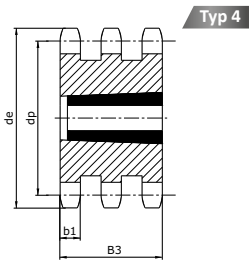
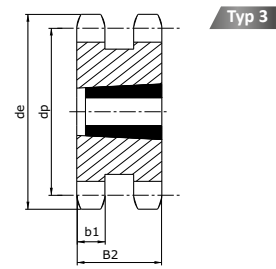
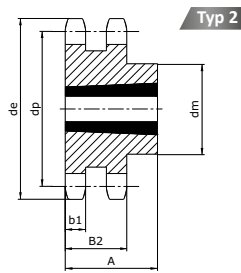
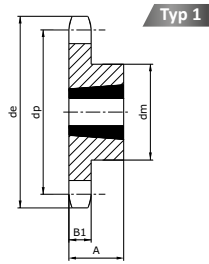

Abmessungen in mm

KETTENRÄDER STAHL FÜR KLEMMBUCHSEN 24 B

B1	B2	B3	b1
5,3	15,4	120,3	23,6

TEILUNG: 1"1/2" x 1"
TEILUNG: 38,1 x 25,4 mm

Z	Art. Nr.	de	dp	EINFACH				ZWEIFACH				DREIFACH						
				dm*	A*	Buchse	Typ	Kg	dm*	A*	Buchse	Typ	Kg	dm*	A*	Buchse	Typ	Kg
11	P..MA24B011	149,0	135,21	90	32	2012	1	1,70										
12	P..MA24B012	161,0	147,22	90	32	2012	1	2,20										
13	P..MA24B013	173,0	159,18	110	44	2517	1	2,80	72	2517	3	5,30						
14	P..MA24B014	185,0	171,22	120	44	2517	1	3,60										
15	P..MA24B015 Δ	197,0	183,26	120	44	2517	1	4,40	72	3020	3	6,60	120,3	3030	5	20,00		
17	P..MA24B017 Δ	221,0	207,34	140	51	3020	1	5,40	72	3020	3	10,30	120,3	3030	5	25,00		
18	P..MA24B018	233,0	219,42	140	51	3020	1	6,10										
19	P..MA24B019 Δ	245,5	231,49	140	51	3020	1	6,60	160	76	3030	2	14,80	120,3	3535	5	30,00	
20	P..MA24B020	257,5	243,57	140	51	3020	1	7,50										
21	P..MA24B021 Δ	270,5	255,65	140	51	3020	1	8,40	160	76	3030	2	19,50	120,3	4040	5	35,00	
23	P..MA24B023 Δ	294,5	279,80	160	51	3020	1	11,30	175	89	3535	2	24,00	120,3	4040	5	44,00	
25	P..MA24B025 Δ	319,0	304,00	160	51	3020	1	13,30	175	89	3535	2	29,00	120,3	4040	5	50,00	
30	P..MA24B030	379,5	364,50	160	51	3020	1		175	89	3535	2	40,00	120,3	4545	5	60,00	

.. 1 für einfach; 2 für zweifach; 3 für dreifach.

*Änderungen der Abmessungen vorbehalten, wenden Sie sich bitte im Bedarfsfall an uns

Gussräder für Einfach-, Zweifach- und Dreifachrollenkettens laut folgenden Normen: DIN 8187 - ISO/R 606.

MATERIAL: Guss
EN-GJL-250 UNI EN 1561

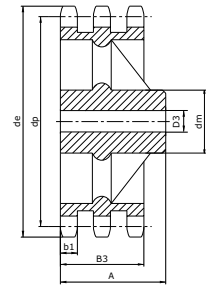
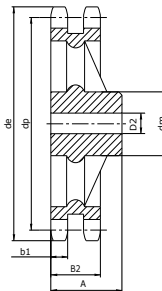
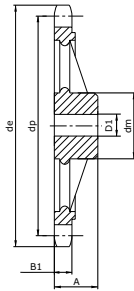

Abmessungen in mm

VORGEBOHRTE GUSSRÄDER 06B

B1	B2	B3	b1
5,3	15,4	25,6	5,1

TEILUNG: 3/8" x 7/32"
TEILUNG: 9,525 x 5,72 mm

Z	Art. Nr.	de	dp	EINFACH				ZWEIFACH				DREIFACH			
				dm*	D1*	A*	Kg	dm*	D2*	A*	Kg	dm*	D3*	A*	Kg
38	F..06B038	119,50	115,34	70	20	32	1,20	80	20	40	1,80	90	24	56	2,20
45	F..06B045	140,70	136,54	70	20	32	1,50	80	20	40	2,20	90	24	56	3,20
57	F..06B057	176,90	172,91	70	20	32	1,90	80	20	40	2,50	90	24	56	3,80
76	F..06B076	234,90	230,49	70	20	32	2,60	80	20	40	3,60	100	24	56	4,80
95	F..06B095	292,50	288,08	80	20	40	3,20	90	20	45	4,10	100	24	56	5,50
114	F..06B114	349,60	345,68	80	20	40	4,20	95	20	45	5,50	100	24	56	8,00
150	F..06B150	459,20	454,80	90	24	45	4,50	100	24	50	7,23	125	24	60	10,50

VORGEBOHRTE GUSSRÄDER 08B

B1	B2	B3	b1
7,2	21	34,9	7

TEILUNG: 1/2" x 3/8"
TEILUNG: 12,7 x 5,16 mm

Z	Art. Nr.	de	dp	EINFACH				ZWEIFACH				DREIFACH			
				dm*	D1*	A*	Kg	dm*	D2*	A*	Kg	dm*	D3*	A*	Kg
38	F..08B038	158,60	153,80	70	24	40	2,70	90	24	50	3,10	100	24	60	4,50
45	F..08B045	188,60	182,07	70	24	40	3,20	90	24	50	3,50	100	24	60	5,30
57	F..08B057	236,40	230,54	70	24	40	4,00	90	24	50	4,40	100	24	60	5,70
76	F..08B076	313,30	307,33	80	24	40	5,20	100	24	56	6,20	100	24	60	9,00
95	F..08B095	390,70	384,11	80	24	45	5,70	100	24	56	9,00	120	24	67	12,40
114	F..08B114	466,90	460,90	80	24	45	7,00	100	24	63	11,00	120	24	67	15,10

VORGEBOHRTE GUSSRÄDER 10B

B1	B2	B3	b1
5,3	15,4	42,1	9

TEILUNG: 5/8" x 3/8"
TEILUNG: 15,875 x 9,65 mm

Z	Art. Nr.	de	dp	EINFACH				ZWEIFACH				DREIFACH			
				dm*	D1*	A*	Kg	dm*	D2*	A*	Kg	dm*	D3*	A*	Kg
38	F..10B038	199,00	192,24	80	24	40	2,90	100	30	50	4,90	100	32	60	6,30
45	F..10B045	235,00	227,58	80	24	40	3,40	100	30	50	5,20	100	32	60	7,50
57	F..10B057	296,00	288,18	90	24	45	4,00	100	30	56	6,30	100	32	63	9,50
76	F..10B076	392,10	384,16	90	24	50	6,40	100	30	63	9,90	110	35	67	14,50
95	F..10B095	488,50	480,14	100	24	56	8,50	110	30	63	13,50	125	35	70	18,50
114	F..10B114	584,10	576,13	100	24	56	14,00	125	30	70	18,00	125	35	80	25,00

.. 1 für einfach; 2 für zweifach; 3 für dreifach.

*Änderungen der Abmessungen vorbehalten, wenden Sie sich bitte im Bedarfsfall an uns

Gussräder für Einfach-, Zweifach- und Dreifachrollenkettens laut folgenden Normen: DIN 8187 - ISO/R 606.

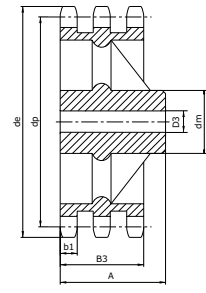
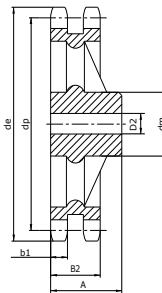
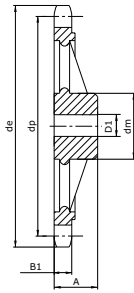

Abmessungen in mm

VORGEBOHRTE GUSSRÄDER 12B

B1	B2	B3	b1
5,3	15,4	49,8	10,8

TEILUNG: 3/4" x 7/16"
TEILUNG: 19,05 x 11,68 mm

Z	Art. Nr.	de	dp	EINFACH				ZWEIFACH				DREIFACH			
				dm*	D1*	A*	Kg	dm*	D2*	A*	Kg	dm*	D3*	A*	Kg
38	F..12B038	238,00	230,69	100	24	56	4,50	110	30	63	6,30	140	30	70	10,60
45	F..12B045	282,50	273,10	100	24	56	5,50	110	30	63	7,50	140	30	70	12,60
57	F..12B057	354,00	345,81	100	30	56	7,00	120	30	63	10,00	140	40	70	15,50
76	F..12B076	469,90	460,99	100	30	56	9,80	135	30	63	15,00	160	40	75	21,80
95	F..12B095	585,10	576,17	100	30	65	12,00	135	30	70	20,00	170	40	82	30,00
114	F..12B114	700,60	691,36	100	30	65	19,00	135	30	70	26,00	170	50	82	38,00

VORGEBOHRTE GUSSRÄDER 16B

B1	B2	B3	b1
5,3	15,4	79,6	15,8

TEILUNG: 1" x 17,02"
TEILUNG: 25,4 x 17,02 mm

Z	Art. Nr.	de	dp	EINFACH				ZWEIFACH				DREIFACH			
				dm*	D1*	A*	Kg	dm*	D2*	A*	Kg	dm*	D3*	A*	Kg
38	F..16B038	320,00	307,59	110	30	65	8,20	140	40	75	15,10	160	45	100	22,20
45	F..16B045	377,00	364,12	125	30	70	10,00	150	40	75	18,00	160	45	100	27,00
57	F..16B057	474,00	461,07	125	35	70	14,70	170	40	90	24,50	165	45	100	39,50
76	F..16B076	627,00	614,65	140	35	80	22,00	175	40	95	37,00	200	45	110	56,00
95	F..16B095	781,00	768,22	140	40	80	33,00	175	45	95	52,00	200	50	110	82,00
114	F..16B114	933,00	921,81	140	40	80	45,00	175	45	95	70,00	200	50	115	105,00

VORGEBOHRTE GUSSRÄDER 20B

B1	B2	B3	b1
5,3	15,4	91	18,2

TEILUNG: 1 1/4" x 3/4"
TEILUNG: 31,75 x 19,56 mm

Z	Art. Nr.	de	dp	EINFACH				ZWEIFACH				DREIFACH			
				dm*	D1*	A*	Kg	dm*	D2*	A*	Kg	dm*	D3*	A*	Kg
38	F..20B038	399,40	384,49	125	35	70	17,70	140	45	90	30,40	180	56	110	49,40
45	F..20B045	470,30	455,17	125	35	70	27,00	140	45	90	40,00	180	56	110	65,00
57	F..20B057	591,50	576,36	135	40	80	40,00	160	50	100	65,00	180	63	125	94,00
76	F..20B076	784,30	768,32	140	50	90	53,30	180	50	100	86,60	200	63	140	125,30
95	F..20B095	975,30	960,27	190	50	100	66,30	200	50	130	108,20	210	50	140	156,60
114	F..20B114	1167,30	1152,27	200	50	110	79,30	200	50	160	129,80	200	50	160	187,90

.. 1 für einfach; 2 für zweifach; 3 für dreifach.
*Änderungen der Abmessungen vorbehalten, wenden Sie sich bitte im Bedarfsfall an uns

Gussräder für Einfach-, Zweifach- und Dreifachrollenkettens laut folgenden Normen: DIN 8187 - ISO 606.

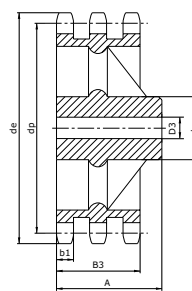
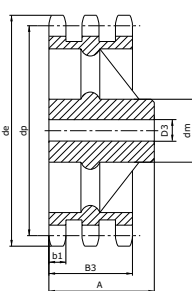
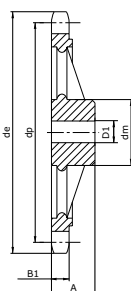

Abmessungen in mm

VORGEBOHRTE GUSSRÄDER 24B

B1	B2	B3	b1
5,3	15,4	120,3	23,6

TEILUNG: 1" 1/2 x 1"
TEILUNG: 38,10 x 25,4 mm

Z	Art. Nr.	de	dp	EINFACH				ZWEIFACH				DREIFACH			
				dm*	D1*	A*	Kg	dm*	D2*	A*	Kg	dm*	D3*	A*	Kg
38	F..24B038	476,20	461,39	140	45	90	17,70	180	45	100	30,40	200	60	150	49,40
45	F..24B045	561,20	546,20	140	45	90	27,00	180	45	100	40,00	200	60	150	65,00
57	F..24B057	706,50	691,63	160	45	100	40,00	200	55	110	65,00	200	70	150	94,00
76	F..24B076	936,90	921,98	170	45	100	53,30	220	55	120	86,60	250	70	150	125,30
95	F..24B095	1167,30	1152,30	200	50	125	130,00	220	55	140	200,00				
114	F..24B114	1397,70	1382,72	200	50	125	206,70	300	55	180	313,40	300	70	200	420,10

VORGEBOHRTE GUSSRÄDER 28B

B1	B2	B3	b1
5,3	15,4	148	28,8

TEILUNG: 1" 3/4 x 1" 1/4
TEILUNG: 44,45 x 30,99

Z	Art. Nr.	de	dp	EINFACH				ZWEIFACH				DREIFACH			
				dm*	D1*	A*	Kg	dm*	D2*	A*	Kg	dm*	D3*	A*	Kg
38	F..28B038	560,00	538,27	200	40	100	37,00	240	45	160	68,00	240	45	180	108,00
45	F..28B045	659,00	637,22	200	40	100	44,00	240	45	160	80,50	240	45	180	142,35
57	F..28B057	828,00	806,99	200	40	100	64,00	240	45	160	116,00	240	45	180	181,00
76	F..28B076	1097,00	1075,60	200	40	100	107,00	240	45	180	172,00	250	45	200	280,00
95	F..28B095	1366,00	1344,40	200	45	120	150,00	240	45	180	239,00	260	45	200	375,00
114	F..28B114	1634,00	1613,20	220	45	120	190,00	280	45	180	280,00	280	45	200	450,00

VORGEBOHRTE GUSSRÄDER 32B

B1	B2	B3	b1
5,3	15,4	146	28,8

TEILUNG: 2" x 1" 1/4
TEILUNG: 50,8 x 30,99 mm

Z	Art. Nr.	de	dp	EINFACH				ZWEIFACH				DREIFACH			
				dm*	D1*	A*	Kg	dm*	D2*	A*	Kg	dm*	D3*	A*	Kg
38	F..32B038	642,50	615,17	200	45	140	77,33	250	45	180	152,32	260	45	200	236,52
45	F..32B045	755,50	728,25	200	45	140	91,96	250	45	180	180,32	260	45	200	311,75
57	F..32B057	922,17	950,00	200	45	140	133,76	250	45	180	259,04	260	45	200	396,39
76	F..32B076	1229,30	1257,00	200	45	140	223,63	250	45	180	385,28	260	45	200	613,20
95	F..32B095	1536,40	1564,00	220	45	140	313,50	260	45	180	535,36	260	45	200	821,25
114	F..32B114	1843,60	1871,00	220	45	140	397,10	280	45	180	627,20	280	45	200	985,50

.. 1 für einfach; 2 für zweifach; 3 für dreifach.

*Änderungen der Abmessungen vorbehalten, wenden Sie sich bitte im Bedarfsfall an uns

Gußräder für Einfach-, Zweifach- und Dreifachrollenkettens laut folgenden Normen: DIN 8187 - ISO 606.

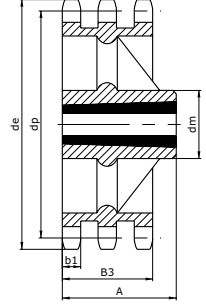
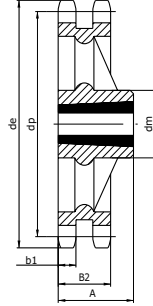
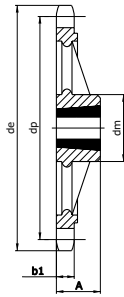

Abmessungen in mm

GUSSRÄDER FÜR KLEMMBUCHSEN 06B

B1	B2	B3	b1
5,3	15,4	25,6	5,2

TEILUNG: 3/8" x 7/32"
TEILUNG: 9,525 x 5,72 mm

Z	Art. Nr.	de	dp	EINFACH				ZWEIFACH				DREIFACH			
				dm*	A*	Buchse	Kg	dm*	A*	Buchse	Kg	dm*	A*	Buchse	Kg
38	F..MA06B038	119,50	115,34	70	25	1210	1,00	80	25	1610	1,50	90	38	1615	2,00
45	F..MA06B045	140,70	136,55	70	25	1210	1,50	80	25	1610	2,30				
57	F..MA06B057	176,90	172,91	70	25	1210	2,20	80	25	1610	2,90				
76	F..MA06B076	234,90	230,49	70	25	1210	2,90	80	25	1610	4,00				
95	F..MA06B095	292,50	288,08	80	25	1210	3,70	90	25	1610	6,20				
114	F..MA06B114	349,50	345,68	80	25	1210	5,60	95	38	1615	8,00				

Auf Nachfrage

GUSSRÄDER FÜR KLEMMBUCHSEN 08B

B1	B2	B3	b1
7,2	21	34,9	7

TEILUNG: 1/2" x 5/16"
TEILUNG: 12,7 x 7,75 mm

Z	Art. Nr.	de	dp	EINFACH				ZWEIFACH				DREIFACH			
				dm*	A*	Buchse	Kg	dm*	A*	Buchse	Kg	dm*	A*	Buchse	Kg
38	F..MA08B038	158,60	153,80	90	32	2012	1,00	100	32	2012	1,90	-	34,9	2012	2,20
45	F..MA08B045	188,60	182,07	100	32	2012	1,60	100	32	2012	2,50				
57	F..MA08B057	236,40	230,54	100	32	2012	2,60	100	32	2012	3,60				
76	F..MA08B076	313,30	307,33	100	32	2012	3,60	100	32	2012	4,90				
95	F..MA08B095	390,10	384,11	100	32	2012	4,70	100	32	2012	6,50				
114	F..MA08B114	466,90	460,90	110	45	2517	8,30	110	45	2517	10,30				

Auf Nachfrage

GUSSRÄDER FÜR KLEMMBUCHSEN 10B

B1	B2	B3	b1
5,3	15,4	42,1	9

TEILUNG: 5/8" x 3/8"
TEILUNG: 15,875 x 9,65

Z	Art. Nr.	de	dp	EINFACH				ZWEIFACH				DREIFACH			
				dm*	A*	Buchse	Kg	dm*	A*	Buchse	Kg	dm*	A*	Buchse	Kg
38	F..MA10B038	199,20	192,24	100	32	2012	3,15								
45	F..MA10B045	235,00	227,58	100	32	2012	3,75	120	45	2517	4,40				
57	F..MA10B057	296,00	288,18	100	32	2012	4,40	120	45	2517	5,80				
76	F..MA10B076	392,10	384,16	100	32	2012	5,10	120	45	2517	7,10				
95	F..MA10B095	488,50	480,14	110	45	2517	8,60	120	45	2517	12,40				
114	F..MA10B114	584,10	576,13	110	45	2517	15,50	120	45	2517	25,30				

Auf Nachfrage

.. 1 für einfach; 2 für zweifach; 3 für dreifach.

*Änderungen der Abmessungen vorbehalten, wenden Sie sich bitte im Bedarfsfall an uns

Gussräder für Einfach-, Zweifach- und Dreifachrollenkettens laut folgenden Normen: DIN 8187 - ISO 606.

MATERIAL: Guss
EN-GJL-250 UNI EN 1561

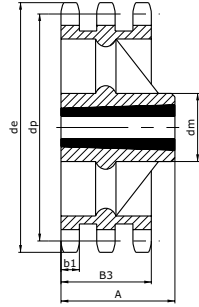
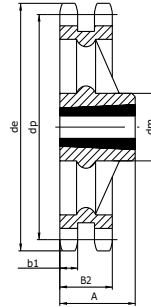
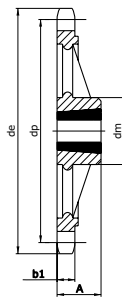

Abmessungen in mm

GUSSRÄDER FÜR KLEMMBUCHSEN 12B

B1	B2	B3	b1
5,3	15,4	49,8	10,8

TEILUNG: 3/4" x 7/16"
TEILUNG: 19,05 x 11,68 mm

Z	Art. Nr.	de	dp	EINFACH				ZWEIFACH				DREIFACH			
				dm*	A*	Buchse	Kg	dm*	A*	Buchse	Kg	dm*	A*	Buchse	Kg
38	F..MA12B038	239,00	230,69	108	45	2517	3,00	140	51	3020	5,10	140	51	3020	7,20
45	F..MA12B045	282,50	273,10	108	45	2517	4,60	140	51	3020	7,70	140	51	3020	10,30
57	F..MA12B057	355,40	345,81	108	45	2517	6,20	140	51	3020	10,00	140	51	3020	13,40
76	F..MA12B076	469,90	460,99	108	45	2517	8,70	140	51	3020	14,40	140	51	3020	18,30
95	F..MA12B095	585,10	576,17	108	45	2517	12,80	140	51	3020	18,60	140	76	3030	26,90
114	F..MA12B114	700,60	691,36	108	64	2525	23,00	140	76	3030	30,60	140	76	3030	48,30

.. 1 für einfach; 2 für zweifach; 3 für dreifach.
*Änderungen der Abmessungen vorbehalten, wenden Sie sich bitte im Bedarfsfall an uns

GUSSRÄDER FÜR KLEMMBUCHSEN 16B

B1	B2	B3	b1
5,3	15,4	79,6	15,8

TEILUNG: 1" x 17,02 mm
TEILUNG: 25,4 x 17,02 mm

Z	Art. Nr.	de	dp	EINFACH				ZWEIFACH				DREIFACH			
				dm*	A*	Buchse	Kg	dm*	A*	Buchse	Kg	dm*	A*	Buchse	Kg
38	F..MA16B038	320,70	307,59	140	51	3020	8,20	140	76	3030	11,70	175	89	3535	21,00
45	F..MA16B045	377,10	364,12	140	51	3020	9,20	140	76	3030	19,80	215	102	4040	28,10
57	F..MA16B057	474,00	461,07	140	51	3020	11,60	175	89	3535	25,70	215	102	4040	37,00
76	F..MA16B076	627,00	614,65	140	51	3020	20,10	175	89	3535	37,00	215	102	4040	53,30
95	F..MA16B095	781,10	768,22	140	51	3020	29,60	215	102	4040	48,00	215	102	4040	78,00
114	F..MA16B114	934,30	921,81	140	76	3020	45,00	215	102	4040	78,00	260	114	4545	100,00

.. 1 für einfach; 2 für zweifach; 3 für dreifach.
*Änderungen der Abmessungen vorbehalten, wenden Sie sich bitte im Bedarfsfall an uns

Gussräder für Einfach-, Zweifach- und Dreifachrollenkettens laut folgenden Normen: DIN 8187 - ISO 606.

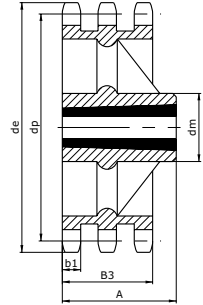
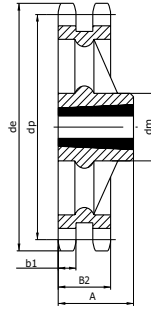
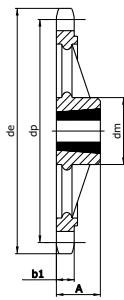

Abmessungen in mm

GUSSRÄDER FÜR KLEMMBUCHSEN 20B

B1	B2	B3	b1
5,3	15,4	91	18,2

TEILUNG: 1" 1/4 x 19,56 mm
TEILUNG: 31,75 x 19,56 mm

Z	Art. Nr.	de	dp	EINFACH				ZWEIFACH				DREIFACH			
				dm*	A*	Buchse	Kg	dm*	A*	Buchse	Kg	dm*	A*	Buchse	Kg
38	F..MA20B038	399,40	384,49	160	51	3020	13,50	160	76	3030	22,00	178	91	3535	35,00
45	F..MA20B045	470,30	455,17	160	51	3020	20,50								
57	F..MA20B057	591,50	576,36	160	51	3020	25,50	175	89	3535	37,00	216	102	4040	42,00
76	F..MA20B076	783,50	768,32	160	51	3020	39,00	175	89	3535	62,00	260	114		

.. 1 für einfach; 2 für zweifach; 3 für dreifach.

*Änderungen der Abmessungen vorbehalten, wenden Sie sich bitte im Bedarfsfall an uns

GUSSRÄDER FÜR KLEMMBUCHSEN 24B

B1	B2	B3	b1
5,3	15,4	120,3	23,6

TEILUNG: 1" 1/2 x 1"
TEILUNG: 38,1 x 25,4 mm

Z	Art. Nr.	de	dp	EINFACH				ZWEIFACH				DREIFACH			
				dm*	A*	Buchse	Kg	dm*	A*	Buchse	Kg	dm*	A*	Buchse	Kg
38	F..MA24B038	476,50	461,39	160	76	3030	24,00	175	89	3535	44,00	120,3	4040	66,00	
57	F..MA24B057	707,50	691,63	160	76	3030	45,00	175	89	3535	72,00	120,3	4545	120,00	
76	F..MA24B076	939,00	921,98	175	89	3035	70,00	216	102	4040	107,00	120,3	4545	131,00	

.. 1 für einfach; 2 für zweifach; 3 für dreifach.

*Änderungen der Abmessungen vorbehalten, wenden Sie sich bitte im Bedarfsfall an uns

KLEMMBUCHSEN

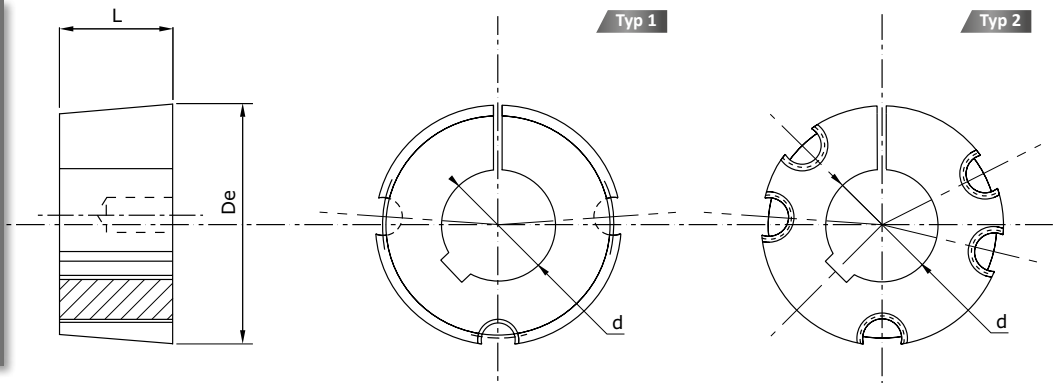

Art. Nr.	Bohrung in mm (d)	De	L	TEILUNG	Typ	Über- moment (Nm)	Anzugs- moment (Nm)	Kg
MA1008A..	9-10-11-12-14-16-18-19-20-22-24-25	35,0	22,3	1/4" x 1/2"	1	136	5,6	0,16
MA1108A..	28,20 9-10-11-12-14-16-18-19-20-22-24-25-28Δ	38,0	22,3	1/4" x 1/2"	1	147	5,6	0,16
MA1210A..	30,25 11-12-14-16-18-19-20-22-24-25-28-30-32	47,5	25,4	3/8" x 5/8"	1	407	19,6	0,32
MA1215A..	30,40 14-19-20-24-25-28-30-32	47,5	38,1	3/8" x 5/8"	1	407	19,6	0,50
MA1610A..	40,25 14-16-18-19-20-22-24-25-28-30-32-35-38-40Δ-42Δ	57,0	25,4	3/8" x 5/8"	1	486	19,6	0,50
MA1615A..	40,40 14-16-18-19-20-22-24-25-28-30-32-35-38-40Δ-42Δ	57,0	38,1	3/8" x 5/8"	1	486	19,6	0,60
MA2012A..	50,30 14-16-18-19-20-22-24-25-28-30-32-35-38-40-42-45-48-50Δ	70,0	31,8	7/16" x 7/8"	1	808	30,4	0,75
MA2517A..	65,45 16-18-19-20-22-24-25-28-30-32-35-38-40-42-45-48-50-55-60	85,5	44,5	1/2" x 1"	1	1310	48,0	1,06
MA3020A..	75,50 25-28-30-32-35-38-40-42-45-48-50-55-60-65-70-75	108,0	50,8	5/8" x 1" 1/4	1	2710	90,0	2,50
MA3030A..	75,75 35-38-40-42-45-48-50-55-60-65-70-75-80	108,0	76,2	5/8" x 1" 1/2	1	2710	90,0	3,75
MA3525A..	35-38-40-42-45-48-50-55-60-65-70-75-80	127,0	64,9	1/2" x 1" 1/2	2	5060	113,0	4,20
MA3535A..	90,90 35-38-40-42-45-48-50-55-60-65-70-75-80-85-90Δ	127,0	88,9	1/2" x 1" 1/2	2	5060	113,0	5,13
MA4030A..	40-42-45-48-50-55-60-65-70-75-80-85-90-100Δ	146,0	76,2	5/8" x 1" 1/2	2	8740	169,0	6,75
MA4040A..	100,100 40-42-45-48-50-55-60-65-70-75-80-85-90-100Δ	146,0	101,6	5/8" x 1" 3/4	2	8740	169,0	7,68
MA4545A..	115,115 55-60-65-70-75-80-85-90-100Δ-115Δ-120Δ	162,0	115,0	3/4" x 2"	2	12400	192,0	10,56
MA5050A..	125,125 70-75-80-85-90-100-105-110-115-120-125	177,6	127,0	7/8" x 2" 1/4	2	12400	272,0	15,17

.. Durchmesser der Bohrung
 Δ Unten liegende Passfeder

Abmessungen der Standard-Passfedernuten

d	a	JS9	F
10 bis 12	4		D + 1,8
" 12 " 17	5	± 0,015	D + 2,3
" 17 " 22	6		D + 2,8
" 22 " 30	8	± 0,018	D + 3,3
" 30 " 38	10		D + 3,3
" 38 " 44	12		D + 3,3
" 44 " 50	14	± 0,021	D + 3,8
" 50 " 58	16		D + 4,3
" 58 " 65	18		D + 4,4
" 65 " 75	20		D + 4,9
" 75 " 85	22	± 0,026	D + 5,4
" 85 " 95	25		D + 5,4
" 95 " 110	28		D + 6,4
" 110 " 130	32	± 0,031	D + 7,4

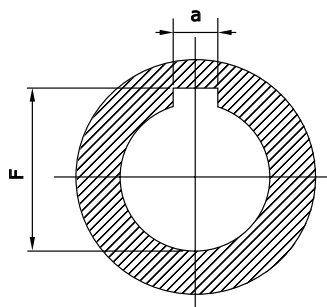

Abmessungen der Standard-Passfedernuten Δ

d	a	F
28	8	D + 1,3
35	10	D + 1,3
40 / 42	12	D + 1,3
50	14	D + 2,8
65	18	D + 2,8
90	25	D + 3,4
100	28	D + 5,4



VORGEBOHRTE KETTENRÄDER MIT GEHÄRTETEN ZÄHNEN 06B

B1	B2	B3	b1
5,3	15,4	-	-

TEILUNG: 3/8" x 7/32"
 TEILUNG: 9,525 x 5,72 mm
 MATERIAL: C45

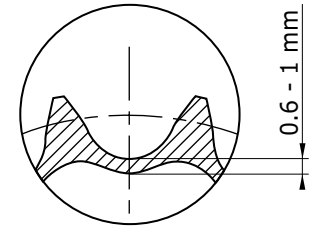
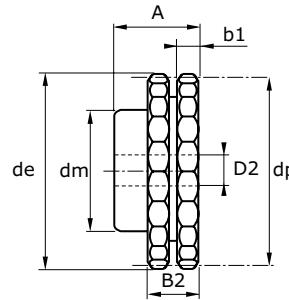
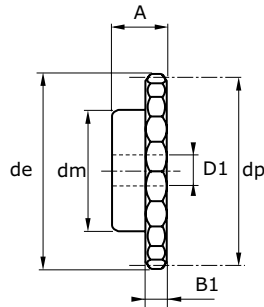

Kettenrad mit einseitiger Nabe für Einfach- und Zweifachrollenkettens laut folgenden Normen: DIN 8187 - ISO 606.
 Induktionsgehärtete Zähne 45-53 HRC.

Abmessungen in mm

Z	Art. Nr.	de	dp	EINFACH				ZWEIFACH			
				dm*	D1*	A*	Kg	dm*	D2*	A*	Kg
8	P..06B008DTT	28,00	24,89	15	8	22	0,03	15	6	22	0,04
9	P..06B009DTT	31,00	27,85	18	8	22	0,04	18	8	22	0,05
10	P..06B010DTT	34,00	30,82	20	8	22	0,03	20	8	22	0,06
11	P..06B011DTT	37,00	33,80	22	8	25	0,06	22	10	25	0,08
12	P..06B012DTT	40,00	36,80	22	8	25	0,11	25	10	25	0,12
13	P..06B013DTT	43,00	39,80	28	10	25	0,13	28	10	25	0,14
14	P..06B014DTT	46,30	42,80	31	10	25	0,16	31	10	25	0,16
15	P..06B015DTT	49,30	45,81	34	10	25	0,18	34	10	25	0,18
16	P..06B016DTT	52,30	48,82	37	10	28	0,24	37	12	30	0,22
17	P..06B017DTT	55,30	51,83	40	10	28	0,28	40	12	30	0,28
18	P..06B018DTT	58,30	54,85	43	10	28	0,33	43	12	30	0,33
19	P..06B019DTT	61,30	57,87	45	10	28	0,36	46	12	30	0,37
20	P..06B020DTT	64,30	60,89	46	10	28	0,39	49	12	30	0,43
21	P..06B021DTT	68,00	63,91	48	12	28	0,42	52	12	30	0,49
22	P..06B022DTT	71,00	66,93	50	12	28	0,46	55	12	30	0,55
23	P..06B023DTT	73,50	69,95	52	12	28	0,50	58	12	30	0,66
24	P..06B024DTT	77,00	72,97	54	12	28	0,54	61	12	30	0,74
25	P..06B025DTT	80,00	76,00	57	12	28	0,60	64	12	30	0,81
26	P..06B026DTT	83,00	79,02	60	12	28	0,72	67	12	30	0,88
27	P..06B027DTT	86,00	82,04	60	12	28	0,76	70	12	30	0,95
28	P..06B028DTT	89,00	85,07	60	12	28	0,82	73	12	30	1,05
30	P..06B030DTT	94,70	91,12	60	12	30	0,95	79	12	30	1,25
32	P..06B032DTT	101,30	97,17	65	14	30	1,02	80	16	30	1,40
34	P..06B034DTT	107,30	103,23	65	14	30	1,06	80	16	30	1,55
35	P..06B035DTT	110,40	106,26	65	14	30	1,10	80	16	30	1,60
36	P..06B036DTT	113,40	109,29	70	16	30	1,30	90	16	30	1,75
38	P..06B038DTT	119,50	115,34	70	16	30	1,35	90	16	30	1,95
40	P..06B040DTT	125,50	121,40	70	16	30	1,40	90	16	30	2,15

*Änderungen der Abmessungen vorbehalten, wenden Sie sich bitte im Bedarfsfall an uns
 .. 1 für einfach; 2 für zweifach.

VORGEBOHRTE KETTENRÄDER MIT GEHÄRTETEN ZÄHNEN 08B

B1	B2	B3	b1
7,2	21	-	-

TEILUNG: 1/2" x 5/16"
 TEILUNG: 12,7 x 7,75 mm
 MATERIAL: C45

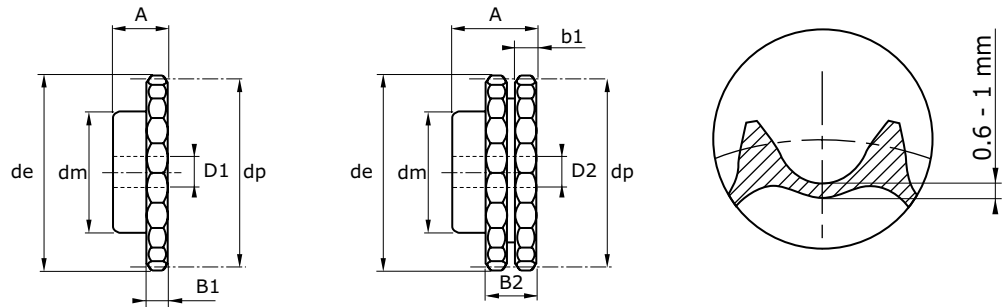

Kettenrad mit einseitiger Nabe für Einfach und Zweifachrollenkettens laut folgenden Normen: DIN 8187 - ISO 606.
 Induktionsgehärtete Zähne 45-53 HRC.

Abmessungen in mm

Z	Art. Nr.	de	dp	EINFACH				ZWEIFACH			
				dm*	D1*	A*	Kg	dm*	D2*	A*	Kg
8	P..08B008DTT	37,20	33,18	20	10	25	0,07	20	10	32	0,15
9	P..08B009DTT	41,00	37,13	24	10	25	0,10	24	10	32	0,15
10	P..08B010DTT	45,20	41,10	26	10	25	0,14	28	10	32	0,19
11	P..08B011DTT	48,70	45,07	29	10	25	0,16	32	12	35	0,27
12	P..08B012DTT	53,00	49,07	33	10	28	0,21	35	12	35	0,32
13	P..08B013DTT	57,40	53,06	37	10	28	0,26	38	12	35	0,37
14	P..08B014DTT	61,80	57,07	41	10	28	0,32	42	12	35	0,44
15	P..08B015DTT	65,50	61,09	45	10	28	0,38	46	12	35	0,50
16	P..08B016DTT	69,50	65,10	50	12	28	0,46	50	14	35	0,62
17	P..08B017DTT	73,60	69,11	52	12	28	0,51	54	14	35	0,72
18	P..08B018DTT	77,80	73,14	56	12	28	0,59	58	14	35	0,86
19	P..08B019DTT	81,70	77,16	60	12	28	0,67	62	14	35	0,93
20	P..08B020DTT	86,80	81,19	64	12	28	0,76	66	14	35	1,05
21	P..08B021DTT	89,70	85,22	68	14	28	0,85	70	16	40	1,15
22	P..08B022DTT	93,80	89,24	70	14	28	0,91	70	16	40	1,40
23	P..08B023DTT	98,20	93,27	70	14	28	0,94	70	16	40	1,60
24	P..08B024DTT	101,80	97,29	70	14	28	0,98	75	16	40	1,70
25	P..08B025DTT	105,80	101,33	70	14	28	1,01	80	16	40	1,95
26	P..08B026DTT	110,00	105,36	70	16	30	1,10	85	16	40	2,10
27	P..08B027DTT	114,00	109,40	70	16	30	1,15	85	16	40	2,20
28	P..08B028DTT	118,00	113,42	70	16	30	1,20	90	16	40	2,40
30	P..08B030DTT	126,40	121,50	80	16	30	1,50	100	16	40	2,80
32	P..08B032DTT	134,30	129,56	90	16	30	1,75	100	20	40	3,35
34	P..08B034DTT	142,70	137,64	90	16	30	1,85	100	20	40	3,60
35	P..08B035DTT	146,00	141,68	90	16	30	1,90	100	20	40	3,75
36	P..08B036DTT	151,00	145,72	90	16	35	2,25	110	20	40	4,10
38	P..08B038DTT	158,60	153,80	90	16	35	2,35	110	20	40	4,45
40	P..08B040DTT	166,70	161,87	90	16	35	2,45	110	20	40	4,75

*Änderungen der Abmessungen vorbehalten, wenden Sie sich bitte im Bedarfsfall an uns
 .. 1 für einfach; 2 für zweifach.



VORGEBOHRTE KETTENRÄDER MIT GEHÄRTETEN ZÄHNEN 10B

B1	B2	B3	b1
9,1	25,5	-	-

TEILUNG: 5/8" x 3/8"
 TEILUNG: 15,875 x 9,65 mm
 MATERIAL: C45

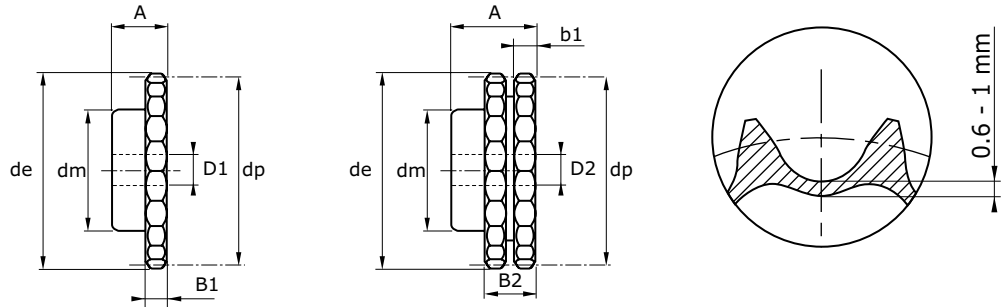

Kettenrad mit einseitiger Nabe für Einfach und Zweifachrollenkettten laut folgenden Normen: DIN 8187 - ISO 606.
 Induktionsgehärtete Zähne 45-53 HRC.

Abmessungen in mm

Z	Art. Nr.	de	dp	EINFACH				ZWEIFACH			
				dm*	D1*	A*	Kg	dm*	D2*	A*	Kg
8	P..10B008DTTT	48,00	41,48	25	10	25	0,13	25	12	40	0,20
9	P..10B009DTTT	52,60	46,42	30	10	25	0,18	30	12	40	0,27
10	P..10B010DTTT	57,50	51,37	35	10	25	0,24	35	12	40	0,33
11	P..10B011DTTT	63,00	56,34	37	12	30	0,32	39	14	40	0,44
12	P..10B012DTTT	68,00	61,34	42	12	30	0,37	44	14	40	0,58
13	P..10B013DTTT	73,00	66,32	47	12	30	0,46	49	14	40	0,72
14	P..10B014DTTT	78,00	71,34	52	12	30	0,56	54	14	40	0,87
15	P..10B015DTTT	83,00	76,36	57	12	30	0,67	59	14	40	0,99
16	P..10B016DTTT	88,00	81,37	60	12	30	0,76	64	16	45	1,30
17	P..10B017DTTT	93,00	86,39	60	12	30	0,88	69	16	45	1,45
18	P..10B018DTTT	98,30	91,42	70	14	30	1,01	74	16	45	1,70
19	P..10B019DTTT	103,30	96,45	70	14	30	1,15	79	16	45	1,85
20	P..10B020DTTT	108,40	101,49	75	14	30	1,21	84	16	45	2,20
21	P..10B021DTTT	113,40	106,52	75	16	30	1,35	85	16	45	2,35
22	P..10B022DTTT	118,00	111,55	80	16	30	1,41	90	16	45	2,60
23	P..10B023DTTT	123,50	116,58	80	16	30	1,47	95	16	45	2,90
24	P..10B024DTTT	128,30	121,62	80	16	30	1,54	100	16	45	3,20
25	P..10B025DTTT	134,00	126,66	80	16	30	1,60	105	16	45	3,45
26	P..10B026DTTT	139,00	131,70	85	20	35	1,85	110	20	45	3,85
27	P..10B027DTTT	144,00	136,75	85	20	35	1,95	110	20	45	4,00
28	P..10B028DTTT	148,70	141,78	90	20	35	2,30	115	20	45	4,35
30	P..10B030DTTT	158,80	151,87	90	20	35	2,41	120	20	45	4,95
32	P..10B032DTTT	168,90	161,95	95	20	35	2,70	120	20	45	5,50
34	P..10B034DTTT	179,00	172,05	95	20	35	2,85	120	20	45	6,05
35	P..10B035DTTT	184,10	177,10	95	20	35	2,90	120	20	45	6,30
36	P..10B036DTTT	189,10	182,15	100	20	35	3,30	120	20	45	6,55
37	P..10B037DTTT	194,20	187,20	100	20	35	3,40	120	20	45	6,80
38	P..10B038DTTT	199,20	192,24	100	20	35	3,50	120	20	45	7,03
40	P..10B040DTTT	209,30	202,34	100	20	35	3,70	120	20	45	7,55

*Änderungen der Abmessungen vorbehalten, wenden Sie sich bitte im Bedarfsfall an uns .. 1 für einfach; 2 für zweifach.

VORGEBOHRTE KETTENRÄDER MIT GEHÄRTETEN ZÄHNEN 12B

B1	B2	B3	b1
11,1	30,3	-	-

TEILUNG: 3/4" x 7/16"
 TEILUNG: 19,05 x 11,68 mm
 MATERIAL: C45

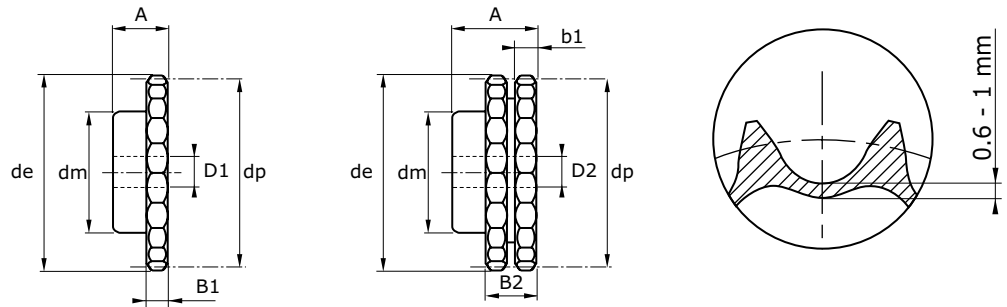

Kettenrad mit einseitiger Nabe für Einfach und Zweifachrollenkettens laut folgenden Normen: DIN 8187 - ISO 606.
 Induktionsgehärtete Zähne 45-53 HRC.

Abmessungen in mm

Z	Art. Nr.	de	dp	EINFACH				ZWEIFACH			
				dm*	D1*	A*	Kg	dm*	D2*	A*	Kg
8	P..12B008DTT	57,60	49,78	31	12	30	0,20	31	12	45	0,30
9	P..12B009DTT	62,00	55,70	37	12	30	0,35	37	12	45	0,45
10	P..12B010DTT	69,00	61,64	42	12	30	0,40	42	12	45	0,64
11	P..12B011DTT	75,00	67,61	46	14	35	0,57	47	16	50	0,89
12	P..12B012DTT	81,50	73,60	52	14	35	0,65	53	16	50	1,10
13	P..12B013DTT	87,50	79,59	58	14	35	0,80	59	16	50	1,30
14	P..12B014DTT	93,60	85,61	64	14	35	0,97	65	16	50	1,60
15	P..12B015DTT	99,80	91,63	70	14	35	1,16	71	16	50	1,80
16	P..12B016DTT	105,50	97,65	75	16	35	1,34	77	20	50	2,15
17	P..12B017DTT	111,90	103,67	80	16	35	1,53	83	20	50	2,55
18	P..12B018DTT	118,00	109,71	80	16	35	1,62	89	20	50	3,10
19	P..12B019DTT	124,20	115,75	80	16	35	1,70	95	20	50	3,35
20	P..12B020DTT	129,70	121,78	80	16	35	1,80	100	20	50	3,85
21	P..12B021DTT	136,00	127,82	90	20	40	2,35	100	20	50	4,05
22	P..12B022DTT	141,80	133,86	90	20	40	2,46	100	20	50	4,30
23	P..12B023DTT	149,00	139,90	90	20	40	2,56	110	20	50	4,80
24	P..12B024DTT	153,90	145,94	90	20	40	2,68	110	20	50	5,00
25	P..12B025DTT	160,00	152,00	90	20	40	2,80	120	20	50	5,55
26	P..12B026DTT	165,90	158,04	95	20	40	3,15	120	20	50	5,90
27	P..12B027DTT	172,30	164,09	95	20	40	3,20	120	20	50	6,20
28	P..12B028DTT	178,00	170,13	95	20	40	3,35	120	20	50	6,55
30	P..12B030DTT	190,50	182,25	95	20	40	3,63	120	20	50	7,20
32	P..12B032DTT	202,30	194,35	100	20	40	3,90	120	20	50	8,25
34	P..12B034DTT	214,60	206,46	100	20	40	4,20	120	20	50	9,10
35	P..12B035DTT	221,00	212,52	100	20	40	4,35	120	20	50	9,45
36	P..12B036DTT	226,80	218,58	100	20	40	4,70	120	25	50	9,90
38	P..12B038DTT	239,00	230,69	100	20	40	5,20	120	25	50	10,80
40	P..12B040DTT	251,30	242,81	100	20	40	5,40	Δ 120	25	50	11,90

*Änderungen der Abmessungen vorbehalten, wenden Sie sich bitte im Bedarfsfall an uns
 .. 1 für einfach; 2 für zweifach.

VORGEBOHRTE KETTENRÄDER MIT GEHÄRTETEN ZÄHNEN 16B

B1	B2	B3	b1
16,2	47,7	-	-

TEILUNG: 1" x 17,02"
 TEILUNG: 25,4 x 17,02 mm
 MATERIAL: C45

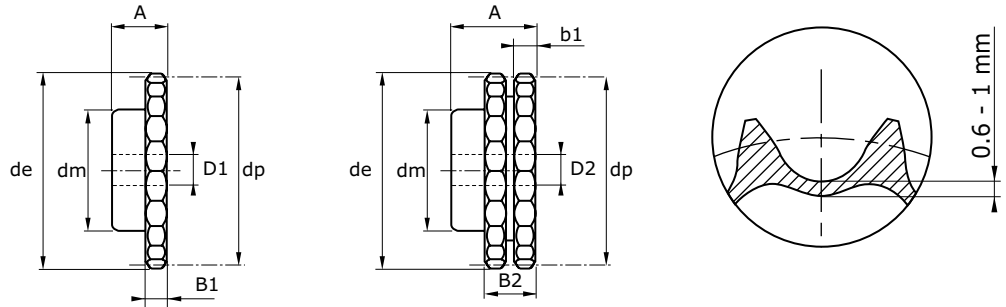

Kettenrad mit einseitiger Nabe für Einfach und Zweifachrollenkettens laut folgenden Normen: DIN 8187 - ISO 606.
 Induktionsgehärtete Zähne 45-53 HRC.

Abmessungen in mm

Z	Art. Nr.	de	dp	EINFACH				ZWEIFACH			
				dm*	D1*	A*	Kg	dm*	D2*	A*	Kg
8	P..16B008DTT	77,00	66,37	42	16	35	0,50	42	16	65	0,60
9	P..16B009DTT	85,00	74,27	50	16	35	0,70	50	16	65	1,20
10	P..16B010DTT	93,00	82,19	55	16	35	0,85	56	16	65	1,70
11	P..16B011DTT	99,50	90,14	61	16	40	1,10	64	20	70	2,15
12	P..16B012DTT	109,00	98,14	69	16	40	1,43	72	20	70	2,65
13	P..16B013DTT	117,00	106,12	78	16	40	1,77	80	20	70	3,40
14	P..16B014DTT	125,00	114,15	84	16	40	2,08	88	20	70	3,95
15	P..16B015DTT	133,00	122,17	92	16	40	2,46	96	20	70	4,45
16	P..16B016DTT	141,0	130,20	100	20	45	3,14	104	20	70	5,25
17	P..16B017DTT	149,00	138,22	100	20	45	3,34	112	20	70	5,85
18	P..16B018DTT	157,00	146,28	100	20	45	3,56	120	20	70	7,00
19	P..16B019DTT	165,20	154,33	100	20	45	3,78	128	20	70	7,70
20	P..16B020DTT	173,20	162,38	100	20	45	4,03	130	20	70	8,90
21	P..16B021DTT	181,20	170,43	110	20	50	5,01	130	25	70	9,75
22	P..16B022DTT	189,30	178,48	110	20	50	5,28	130	25	70	10,30
23	P..16B023DTT	197,50	186,53	110	20	50	5,56	130	25	70	11,20
24	P..16B024DTT	205,50	194,59	110	20	50	5,86	130	25	70	12,00
25	P..16B025DTT	213,50	202,66	110	20	50	6,16	130	25	70	12,70
26	P..16B026DTT	221,60	210,72	120	20	50	6,40	130	25	70	13,80
27	P..16B027DTT	229,60	218,79	120	20	50	6,65	130	25	70	14,50
28	P..16B028DTT	237,70	226,85	120	20	50	6,95	130	25	70	15,60
30	P..16B030DTT	254,00	243,00	120	20	50	7,65	130	25	70	17,40
32	P..16B032DTT	270,00	259,13	120	25	50	8,40	140	25	70	19,60
34	P..16B034DTT	287,00	275,28	120	25	50	9,25	140	25	70	22,00
35	P..16B035DTT	296,20	283,36	120	25	50	9,60	140	25	70	23,10
36	P..16B036DTT	304,60	291,44	120	25	50	9,95	140	25	70	24,70
38	P..16B038DTT	320,70	307,59	120	25	50	10,70	140	25	70	27,20
40	P..16B040DTT	336,90	323,73	120	25	50	11,90	140	25	70	29,90

*Änderungen der Abmessungen vorbehalten, wenden Sie sich bitte im Bedarfsfall an uns .. 1 für einfach; 2 für zweifach.

VORGEBOHRTE KETTENRÄDER MIT GEHÄRTETEN ZÄHNEN 20B

B1
18,5

B2
54,6

B3
-

b1
-

TEILUNG: 1"1/4 x 3/4"
TEILUNG: 31,75 x 19,56 mm
MATERIAL: C45

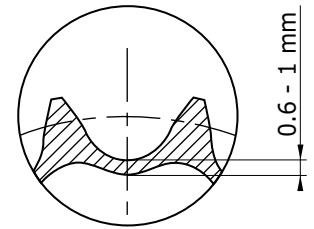
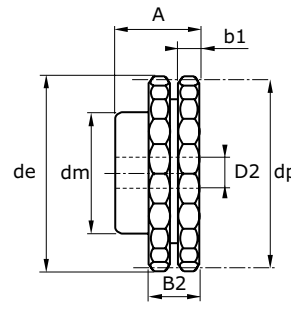
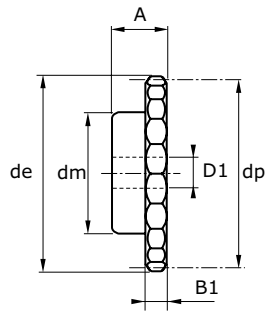

Kettenrad mit einseitiger Nabe für Einfach und Zweifachrollenkettens laut folgenden Normen: DIN 8187 - ISO 606.
Induktionsgehärtete Zähne 45-53 HRC.

Abmessungen in mm

Z	Art. Nr.	de	dp	EINFACH				ZWEIFACH			
				dm*	D1*	A*	Kg	dm*	D2*	A*	Kg
8	P..20B008DTT	98,10	82,96	53	20	40	0,90	53	20	75	1,75
9	P..20B009DTT	108,00	92,84	63	20	40	1,25	63	20	75	2,75
10	P..20B010DTT	117,90	102,74	70	20	40	1,75	70	20	75	3,60
11	P..20B011DTT	127,80	112,68	77	20	45	2,25	80	25	80	4,75
12	P..20B012DTT	137,80	122,68	88	20	45	2,75	90	25	80	5,70
13	P..20B013DTT	147,80	132,65	98	20	45	3,30	100	25	80	6,75
14	P..20B014DTT	157,80	142,68	108	20	45	4,10	110	25	80	8,00
15	P..20B015DTT	167,90	152,72	118	20	45	5,25	120	25	80	10,00
16	P..20B016DTT	177,90	162,75	120	25	50	5,50	120	30	80	11,20
17	P..20B017DTT	187,90	172,78	120	25	50	5,80	120	30	80	12,20
18	P..20B018DTT	198,00	182,85	120	25	50	6,20	120	30	80	13,50
19	P..20B019DTT	208,10	192,91	120	25	50	6,50	120	30	80	14,50
20	P..20B020DTT	218,10	202,98	120	25	50	7,00	120	30	80	15,80
21	P..20B021DTT	228,20	213,04	140	25	55	9,00	140	30	80	17,20
22	P..20B022DTT	238,30	223,11	140	25	55	9,50	140	30	80	18,50
23	P..20B023DTT	248,30	233,17	140	25	55	10,00	140	30	80	20,00
24	P..20B024DTT	258,40	243,23	140	25	55	10,50	140	30	80	21,50
25	P..20B025DTT	268,50	253,33	140	25	55	11,60	140	30	80	24,00
26	P..20B026DTT	278,60	263,40	150	30	55	12,10	150	30	80	27,00
27	P..20B027DTT	288,60	273,48	150	30	55	12,80	150	30	80	28,50
28	P..20B028DTT	298,70	283,56	150	30	55	13,40	150	30	80	30,50
29	P..20B029DTT	308,80	293,65	150	30	55	14,10	150	30	80	32,20
30	P..20B030DTT	318,90	303,75	150	30	55	14,50	150	30	80	34,00
32	P..20B032DTT	339,10	323,91	Δ 160	30	55	16,10	Δ 150	30	80	38,50
34	P..20B034DTT	359,30	344,10	Δ 160	30	55	17,50	Δ 150	30	80	43,10
35	P..20B035DTT	369,20	354,20	Δ 160	30	55	18,50	Δ 150	30	80	45,00
36	P..20B036DTT	379,50	364,30	Δ 160	30	55	19,00	Δ 150	30	80	47,50
38	P..20B038DTT	399,40	384,49	Δ 160	30	55	20,50	Δ 150	30	80	53,50
40	P..20B040DTT	419,80	404,66	Δ 160	30	55	22,50	Δ 150	30	80	57,50

*Änderungen der Abmessungen vorbehalten, wenden Sie sich bitte im Bedarfsfall an uns
.. 1 für einfach; 2 für zweifach.

MONTAGEFERTIGE KETTENRÄDER 06B

r 10
C 1
B1 5,3

TEILUNG: 3/8" x 7/32"
TEILUNG: 9,525 x 5,72 mm
MATERIAL: C45



Kettenrad mit einseitiger Nabe für Einfachrollenkettens laut folgenden Normen: DIN 8187 - ISO 606. Montagefertig mit H7 Bohrung, Keilnut JS9 in der Achse eines Zahns, zwei um 90° versetzte Gewindebohrungen und induktionsgehärtete Verzahnungen 45/53 HRC.

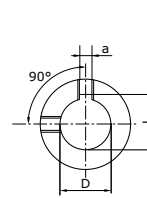
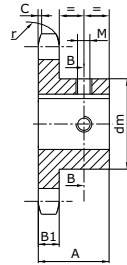
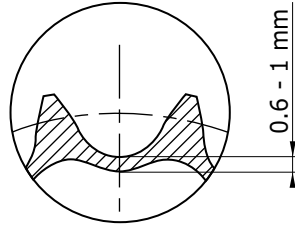

B-B

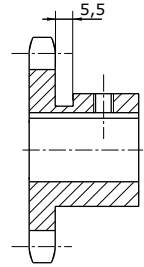

Für Abmessungen a, L und M siehe Tabelle Seite 103

Abmessungen in mm

Z	Art. Nr.	D	A	dm	Z	Art. Nr.	D	A	dm	Z	Art. Nr.	D	A	dm		
10	P106B010/10	10	22	24	17	P106B017/12	12	28	40	22	P106B022/15	15	28	50		
	P106B010/11	11	22	24		P106B017/14	14	28	40		P106B022/16	16	28	50		
	P106B010/12	12	22	26		P106B017/15	15	28	40		P106B022/18	18	28	50		
	P106B010/14	14	22	29		P106B017/16	16	28	40		P106B022/19	19	28	50		
11	P106B011/10	10	25	24	18	P106B017/18	18	28	40	23	P106B022/20	20	28	50		
	P106B011/12	12	25	26		P106B017/19	19	28	40		P106B022/22	22	28	50		
	P106B011/14	14	25	29Δ		P106B017/20	20	28	40		P106B022/24	24	28	50		
	P106B011/15	15	25	30Δ		P106B017/22	22	28	40		P106B022/25	25	28	50		
12	P106B011/16	16	25	31Δ	19	P106B017/24	24	28	40	24	P106B023/15	15	28	52		
	P106B012/10	10	25	25		P106B017/25	25	28	42		P106B023/16	16	28	52		
	P106B012/12	12	25	26		20	P106B018/12	12	28		43	P106B023/18	18	28	52	
	P106B012/14	14	25	29			P106B018/14	14	28		43	P106B023/19	19	28	52	
P106B012/15	15	25	30	P106B018/15	15		28	43	P106B023/20	20	28	52				
P106B012/16	16	25	31Δ	P106B018/16	16		28	43	P106B023/22	22	28	52				
13	P106B013/10	10	25	28	21	P106B018/18	18	28	43	25	P106B023/24	24	28	52		
		P106B013/12	12	25		28	P106B018/19	19	28		43	P106B023/25	25	28	52	
		P106B013/14	14	25		29	P106B018/20	20	28		43	P106B024/15	15	28	54	
		P106B013/15	15	25		30	P106B018/22	22	28		43	P106B024/16	16	28	54	
14	P106B013/16	16	25	31	22	P106B018/24	24	28	43	30	P106B024/18	18	28	54		
	P106B013/18	18	25	35Δ		P106B018/25	25	28	43		P106B024/19	19	28	54		
	P106B014/12	12	25	31		23	P106B019/12	12	28		45	P106B024/20	20	28	54	
		P106B014/14	14	25			31	P106B019/14	14		28	45	P106B024/22	22	28	54
P106B014/15		15	25	31	P106B019/15		15	28	45	P106B024/24	24	28	54			
P106B014/16		16	25	31	P106B019/16		16	28	45	P106B024/25	25	28	54			
15	P106B014/18	18	25	35	24	P106B019/18	18	28	45	25	P106B025/16	16	28	57		
	P106B014/19	19	25	35		P106B019/19	19	28	45		P106B025/18	18	28	57		
	P106B015/12	12	25	34		25	P106B019/20	20	28		45	P106B025/19	19	28	57	
		P106B015/14	14	25			34	P106B019/22	22		28	45	P106B025/20	20	28	57
P106B015/15		15	25	34	P106B019/24		24	28	45	P106B025/22	22	28	57			
P106B015/16		16	25	34	P106B019/25		25	28	45	P106B025/24	24	28	57			
16	P106B015/18	18	25	34	26	P106B020/12	12	28	46	30	P106B025/25	25	28	57		
	P106B015/19	19	25	35		P106B020/14	14	28	46		P106B030/20	20	30	60		
	P106B015/20	20	25	36		P106B020/15	15	28	46		P106B030/22	22	30	60		
	P106B015/22	22	25	38		P106B020/16	16	28	46		P106B030/24	24	30	60		
17	P106B015/24	24	25	42Δ	27	P106B020/18	18	28	46	31	P106B030/25	25	30	60		
	P106B015/25	25	25	42Δ		P106B020/19	19	28	46		P106B030/28	28	30	60		
	P106B016/12	12	28	37		28	P106B020/20	20	28		46	32	P106B030/30	30	30	60
		P106B016/14	14	28			37	P106B020/22	22		28		46			
P106B016/15		15	28	37	P106B020/24		24	28	46							
P106B016/16		16	28	37	P106B020/25		25	28	46							
18	P106B016/18	18	28	37	29	P106B021/15	15	28	48							
	P106B016/19	19	28	37		P106B021/16	16	28	48							
	P106B016/20	20	28	37		P106B021/18	18	28	48							
	P106B016/22	22	28	37		P106B021/19	19	28	48							
19	P106B016/24	24	28	42	30	P106B021/20	20	28	48							
	P106B016/25	25	28	42		P106B021/22	22	28	48							
	P106B017/12	12	28	40		31	P106B021/24	24	28	48						
		P106B017/14	14	28			40	P106B021/25	25	28	48					
P106B017/15		15	28	40												
P106B017/16		16	28	40												

Δ = Kettenradmodell mit Nut

MONTAGEFERTIGE KETTENRÄDER 08B

r 13 **C** 1,3 **B1** 7,2

TEILUNG: 1/2" x 5/16"
TEILUNG: 12,7 x 7,75 mm
MATERIAL: C45



Kettenrad mit einseitiger Nabe für Einfachrollenkettens laut folgenden Normen: DIN 8187 - ISO 606. Montagefertig mit H7 Bohrung, Keilnut JS9 in der Achse eines Zahns, zwei um 90° versetzte Gewindebohrungen und induktionsgehärtete Verzahnungen 45/53 HRC.

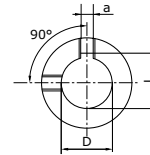
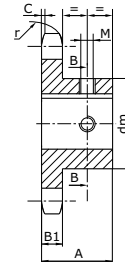
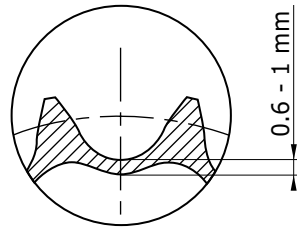

B-B

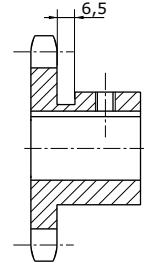

Für Abmessungen a, L und M siehe Tabelle Seite 103

Abmessungen in mm

Z	Art. Nr.	D	A	dm	Z	Art. Nr.	D	A	dm	Z	Art. Nr.	D	A	dm	
10	P108B010/12	12	25	26	16	P108B016/15	15	28	50	21	P108B021/16	16	28	68	
	P108B010/14	14	25	29		P108B016/16	16	28	50		P108B021/18	18	28	68	
	P108B010/15	15	25	30		P108B016/18	18	28	50		P108B021/19	19	28	68	
	P108B010/16	16	25	31		P108B016/19	19	28	50		P108B021/20	20	28	68	
11	P108B011/12	12	25	29	17	P108B017/20	20	28	50	22	P108B022/21	21	28	68	
	P108B011/14	14	25	29		P108B017/22	22	28	50		P108B022/22	22	28	68	
	P108B011/15	15	25	30		P108B017/24	24	28	50		P108B022/24	24	28	68	
	P108B011/16	16	25	31		P108B017/25	25	28	50		P108B022/25	25	28	68	
12	P108B011/18	18	25	34	18	P108B018/28	28	28	50	23	P108B023/28	28	28	68	
	P108B011/19	19	25	35		P108B018/30	30	28	50		P108B023/30	30	28	68	
	P108B012/12	12	28	33		P108B018/32	32	28	52		P108B023/32	32	28	68	
	P108B012/14	14	28	33		P108B018/35	35	28	56		P108B023/35	35	28	68	
13	P108B012/15	15	28	33	19	P108B019/16	16	28	60	24	P108B024/38	38	28	70	
	P108B012/16	16	28	33		P108B019/18	18	28	60		P108B024/19	19	28	70	
	P108B012/18	18	28	33		P108B019/19	19	28	60		P108B024/20	20	28	70	
	P108B012/19	19	28	35		P108B019/20	20	28	60		P108B024/22	22	28	70	
14	P108B012/20	20	28	36	20	P108B020/22	22	28	64	25	P108B025/24	24	28	70	
	P108B012/22	22	28	38		P108B020/24	24	28	64		P108B025/25	25	28	70	
	P108B012/24	24	28	41Δ		P108B020/25	25	28	64		P108B025/28	28	28	70	
	P108B012/25	25	28	42Δ		P108B020/28	28	28	64		P108B025/30	30	28	70	
15	P108B013/12	12	28	37	20	P108B020/30	30	28	64	30	P108B030/25	25	30	80	
	P108B013/14	14	28	37		P108B020/32	32	28	64		P108B030/28	28	30	80	
	P108B013/15	15	28	37		P108B020/35	35	28	64		P108B030/30	30	30	80	
	P108B013/16	16	28	37		P108B020/38	38	28	64		P108B030/32	32	30	80	
16	P108B013/18	18	28	37	20	P108B020/38	38	28	64	30	P108B030/35	35	30	80	
	P108B013/19	19	28	37							P108B030/38	38	30	80	
	P108B013/20	20	28	37											
	P108B013/22	22	28	37											

Δ = Kettenradmodell mit Nut

MONTAGEFERTIGE KETTENRÄDER 10B

r	C	B1
10	1	9,10

TEILUNG: 5/8" x 3/8"
TEILUNG: 15,875 x 9,65 mm
MATERIAL: C45



Kettenrad mit einseitiger Nabe für Einfachrollenkettens laut folgenden Normen: DIN 8187 - ISO 606. Montagefertig mit H7 Bohrung, Keilnut JS9 in der Achse eines Zahns, zwei um 90° versetzte Gewindebohrungen und induktionsgehärtete Verzahnungen 45/53 HRC.

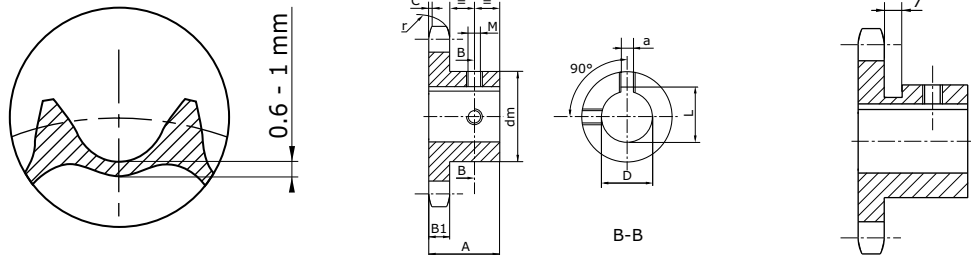

Für Abmessungen a, L und M siehe Tabelle Seite 103

Abmessungen in mm

Z	Art. Nr.	D	A	dm	Z	Art. Nr.	D	A	dm	Z	Art. Nr.	D	A	dm
10	P110B010/15	15	25	35	16	P110B016/19	19	30	60	21	P110B021/19	19	30	75
	P110B010/16	16	25	35		P110B016/20	20	30	60		P110B021/20	20	30	75
	P110B010/19	19	25	35		P110B016/22	22	30	60		P110B021/22	22	30	75
	P110B010/20	20	25	35		P110B016/24	24	30	60		P110B021/24	24	30	75
	P110B010/24	24	25	42 Δ		P110B016/25	25	30	60		P110B021/25	25	30	75
11	P110B011/15	15	30	37	17	P110B017/19	19	30	60	22	P110B022/19	19	30	80
	P110B011/16	16	30	37		P110B017/20	20	30	60		P110B022/20	20	30	80
	P110B011/18	18	30	37		P110B017/22	22	30	60		P110B022/22	22	30	80
	P110B011/19	19	30	37		P110B017/24	24	30	60		P110B022/24	24	30	80
	P110B011/20	20	30	37		P110B017/28	28	30	60		P110B022/25	25	30	80
	P110B011/24	24	30	42		P110B017/30	30	30	60		P110B022/28	28	30	80
	P110B011/25	25	30	42		P110B017/32	32	30	60		P110B022/30	30	30	80
	P110B011/28	28	30	45		P110B017/35	35	30	60		P110B022/32	32	30	80
12	P110B012/15	15	30	42	18	P110B018/19	19	30	70	23	P110B023/19	19	30	80
	P110B012/16	16	30	42		P110B018/20	20	30	70		P110B023/20	20	30	80
	P110B012/18	18	30	42		P110B018/22	22	30	70		P110B023/22	22	30	80
	P110B012/19	19	30	42		P110B018/24	24	30	70		P110B023/24	24	30	80
	P110B012/20	20	30	42		P110B018/25	25	30	70		P110B023/25	25	30	80
	P110B012/22	22	30	42		P110B018/28	28	30	70		P110B023/28	28	30	80
	P110B012/24	24	30	42		P110B018/30	30	30	70		P110B023/30	30	30	80
	P110B012/25	25	30	44		P110B018/32	32	30	70		P110B023/32	32	30	80
	P110B012/28	28	30	47		P110B018/35	35	30	70		P110B023/35	35	30	80
	P110B012/30	30	30	49		P110B018/38	38	30	70		P110B023/38	38	30	80
	P110B012/32	32	30	51		P110B018/40	40	30	70		P110B023/40	40	30	80
	13	P110B013/15	15	30		47	19	P110B019/19	19		30	70	24	P110B024/19
P110B013/16		16	30	47	P110B019/20	20		30	70	P110B024/20	20	30		80
P110B013/18		18	30	47	P110B019/22	22		30	70	P110B024/22	22	30		80
P110B013/19		19	30	47	P110B019/24	24		30	70	P110B024/24	24	30		80
P110B013/20		20	30	47	P110B019/25	25		30	70	P110B024/25	25	30		80
P110B013/22		22	30	47	P110B019/28	28		30	70	P110B024/28	28	30		80
P110B013/24		24	30	47	P110B019/30	30		30	70	P110B024/30	30	30		80
P110B013/25		25	30	47	P110B019/32	32		30	70	P110B024/32	32	30		80
P110B013/28		28	30	47	P110B019/35	35		30	70	P110B024/35	35	30		80
P110B013/30		30	30	49	P110B019/38	38		30	70	P110B024/38	38	30		80
14	P110B014/15	15	30	52	20	P110B020/19	19	30	75	25	P110B025/19	19	30	80
	P110B014/16	16	30	52		P110B020/20	20	30	75		P110B025/20	20	30	80
	P110B014/18	18	30	52		P110B020/22	22	30	75		P110B025/22	22	30	80
	P110B014/19	19	30	52		P110B020/24	24	30	75		P110B025/24	24	30	80
	P110B014/20	20	30	52		P110B020/25	25	30	75		P110B025/25	25	30	80
	P110B014/22	22	30	52		P110B020/28	28	30	75		P110B025/28	28	30	80
	P110B014/24	24	30	52		P110B020/30	30	30	75		P110B025/30	30	30	80
	P110B014/25	25	30	52		P110B020/32	32	30	75		P110B025/32	32	30	80
	P110B014/28	28	30	52		P110B020/35	35	30	75		P110B025/35	35	30	80
	P110B014/30	30	30	52		P110B020/38	38	30	75		P110B025/38	38	30	80
	P110B014/32	32	30	52		P110B020/40	40	30	75		P110B025/40	40	30	80
	15	P110B015/19	19	30		57	25	P110B020/42	42		30	75	P110B025/42	42
P110B015/20		20	30	57										
P110B015/22		22	30	57										
P110B015/24		24	30	57										
P110B015/25		25	30	57										
P110B015/28		28	30	57										
P110B015/30		30	30	57										
P110B015/32		32	30	57										

Δ = Kettenradmodell mit Nut

MONTAGEFERTIGE KETTENRÄDER 12 B

r	C	B1
19	2	11,1

TEILUNG: 3/4" x 7/16"
 TEILUNG: 19,05 x 11,68 mm
 MATERIAL: C45



Kettenrad mit einseitiger Nabe für Einfachrollenkettens laut folgenden Normen: DIN 8187 - ISO 606. Montagefertig mit H7 Bohrung, Keilnut JS9 in der Achse eines Zahns, zwei um 90° versetzte Gewindebohrungen und induktionsgehärtete Verzahnungen 45/53 HRC.

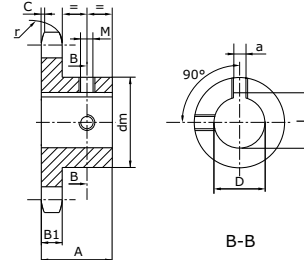
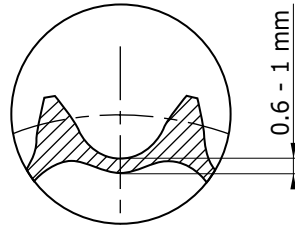

Für Abmessungen a, L und M siehe Tabelle Seite 103

Abmessungen in mm

Z	Art. Nr.	D	A	dm	Z	Art. Nr.	D	A	dm	Z	Art. Nr.	D	A	dm
10	P112B010/19	19	30	42	16	P112B016/19	19	35	75	22	P112B022/25	25	40	90
	P112B010/20	20	30	42		P112B016/20	20	35	75		P112B022/28	28	40	90
	P112B010/24	24	30	42		P112B016/22	22	35	75		P112B022/30	30	40	90
	P112B010/25	25	30	42		P112B016/24	24	35	75		P112B022/32	32	40	90
	P112B010/28	28	30	45		P112B016/25	25	35	75		P112B022/35	35	40	90
	P112B010/30	30	30	47		P112B016/28	28	35	75		P112B022/38	38	40	90
11	P112B011/19	19	35	46	17	P112B017/25	25	35	80	23	P112B023/25	25	40	90
	P112B011/20	20	35	46		P112B017/28	28	35	80		P112B023/28	28	40	90
	P112B011/24	24	35	46		P112B017/30	30	35	80		P112B023/30	30	40	90
	P112B011/25	25	35	46		P112B017/32	32	35	80		P112B023/32	32	40	90
	P112B011/28	28	35	49		P112B017/35	35	35	80		P112B023/35	35	40	90
	P112B011/30	30	35	51		P112B017/38	38	35	80		P112B023/38	38	40	90
12	P112B012/19	19	35	52	18	P112B018/25	25	35	80	24	P112B024/25	25	40	90
	P112B012/20	20	35	52		P112B018/28	28	35	80		P112B024/28	28	40	90
	P112B012/22	22	35	52		P112B018/30	30	35	80		P112B024/30	30	40	90
	P112B012/24	24	35	52		P112B018/32	32	35	80		P112B024/32	32	40	90
	P112B012/25	25	35	52		P112B018/35	35	35	80		P112B024/35	35	40	90
	P112B012/28	28	35	52		P112B018/38	38	35	80		P112B024/38	38	40	90
13	P112B013/19	19	35	58	19	P112B019/25	25	35	80	25	P112B025/25	25	40	90
	P112B013/20	20	35	58		P112B019/28	28	35	80		P112B025/28	28	40	90
	P112B013/22	22	35	58		P112B019/30	30	35	80		P112B025/30	30	40	90
	P112B013/24	24	35	58		P112B019/32	32	35	80		P112B025/32	32	40	90
	P112B013/25	25	35	58		P112B019/35	35	35	80		P112B025/35	35	40	90
	P112B013/28	28	35	58		P112B019/38	38	35	80		P112B025/38	38	40	90
14	P112B014/19	19	35	64	20	P112B020/25	25	35	80	21	P112B021/25	25	40	90
	P112B014/20	20	35	64		P112B020/28	28	35	80		P112B021/28	28	40	90
	P112B014/22	22	35	64		P112B020/30	30	35	80		P112B021/30	30	40	90
	P112B014/24	24	35	64		P112B020/32	32	35	80		P112B021/32	32	40	90
	P112B014/25	25	35	64		P112B020/35	35	35	80		P112B021/35	35	40	90
	P112B014/28	28	35	64		P112B020/38	38	35	80		P112B021/38	38	40	90
15	P112B015/19	19	35	70	21	P112B021/40	40	35	80	21	P112B021/40	40	40	90
	P112B015/20	20	35	70		P112B021/42	42	35	80		P112B021/42	42	40	90
	P112B015/22	22	35	70		P112B021/45	45	35	80		P112B021/45	45	40	90
	P112B015/24	24	35	70		P112B021/48	48	35	80		P112B021/48	48	40	90
	P112B015/25	25	35	70		P112B021/50	50	35	80		P112B021/50	50	40	90
	P112B015/28	28	35	70										

MONTAGEFERTIGE KETTENRÄDER 16B

r 26 C 2,5 B1 16,2

TEILUNG: 1" x 17,02 mm
TEILUNG: 25,4 x 17,02 mm
MATERIAL: C45



Kettenrad mit einseitiger Nabe für Einfachrollenketten laut folgenden Normen: DIN 8187 - ISO 606. Montagefertig mit H7 Bohrung, Keilnut JS9 in der Achse eines Zahns, zwei um 90° versetzte Gewindebohrungen und induktionsgehärtete Verzahnungen 45/53 HRC.

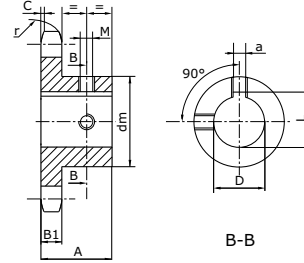
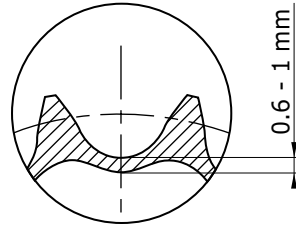

Für Abmessungen a, L und M siehe Tabelle Seite 103

Abmessungen in mm

Z	Art. Nr.	D	A	dm	Z	Art. Nr.	D	A	dm	Z	Art. Nr.	D	A	dm
11	P116B011/25	25	40	61	17	P116B017/25	25	45	100	22	P116B022/25	25	50	110
	P116B011/28	28	40	61		P116B017/28	28	45	100		P116B022/28	28	50	110
	P116B011/30	30	40	61		P116B017/30	30	45	100		P116B022/30	30	50	110
	P116B011/32	32	40	61		P116B017/32	32	45	100		P116B022/32	32	50	110
	P116B011/35	35	40	61		P116B017/35	35	45	100		P116B022/35	35	50	110
	P116B011/38	38	40	65		P116B017/38	38	45	100		P116B022/38	38	50	110
	P116B011/40	40	40	67		P116B017/40	40	45	100		P116B022/40	40	50	110
P116B011/42	42	40	69	P116B017/42	42	45	100	P116B022/42	42	50	110			
12	P116B012/25	25	40	69	P116B017/45	45	45	100	P116B022/45	45	50	110		
	P116B012/28	28	40	69	P116B017/48	48	45	100	P116B022/48	48	50	110		
	P116B012/30	30	40	69	P116B017/50	50	45	100	P116B022/50	50	50	110		
	P116B012/32	32	40	69	P116B018/25	25	45	100	P116B023/25	25	50	110		
	P116B012/35	35	40	69	P116B018/28	28	45	100	P116B023/28	28	50	110		
	P116B012/38	38	40	69	P116B018/30	30	45	100	P116B023/30	30	50	110		
	P116B012/40	40	40	69	P116B018/32	32	45	100	P116B023/32	32	50	110		
P116B012/42	42	40	69	P116B018/35	35	45	100	P116B023/35	35	50	110			
13	P116B013/25	25	40	78	18	P116B018/38	38	45	100	23	P116B023/38	38	50	110
	P116B013/28	28	40	78		P116B018/40	40	45	100		P116B023/40	40	50	110
	P116B013/30	30	40	78		P116B018/42	42	45	100		P116B023/42	42	50	110
	P116B013/32	32	40	78		P116B018/45	45	45	100		P116B023/45	45	50	110
	P116B013/35	35	40	78		P116B018/48	48	45	100		P116B023/48	48	50	110
	P116B013/38	38	40	78		P116B018/50	50	45	100		P116B023/50	50	50	110
	P116B013/40	40	40	78		P116B019/25	25	45	100		P116B024/25	25	50	110
P116B013/42	42	40	78	P116B019/28	28	45	100	P116B024/28	28	50	110			
14	P116B013/45	45	40	78	19	P116B019/30	30	45	100	24	P116B024/30	30	50	110
	P116B013/48	48	40	78		P116B019/32	32	45	100		P116B024/32	32	50	110
	P116B013/50	50	40	82		P116B019/35	35	45	100		P116B024/35	35	50	110
	P116B014/25	25	40	84		P116B019/38	38	45	100		P116B024/38	38	50	110
	P116B014/28	28	40	84		P116B019/40	40	45	100		P116B024/40	40	50	110
	P116B014/30	30	40	84		P116B019/42	42	45	100		P116B024/42	42	50	110
	P116B014/32	32	40	84		P116B019/45	45	45	100		P116B024/45	45	50	110
P116B014/35	35	40	84	P116B019/48	48	45	100	P116B024/48	48	50	110			
P116B014/38	38	40	84	P116B019/50	50	45	100	P116B024/50	50	50	110			
P116B014/40	40	40	84	20	P116B020/25	25	45	100	25	P116B025/25	25	50	110	
P116B014/42	42	40	84		P116B020/28	28	45	100		P116B025/28	28	50	110	
P116B014/45	45	40	84		P116B020/30	30	45	100		P116B025/30	30	50	110	
P116B014/48	48	40	84		P116B020/32	32	45	100		P116B025/32	32	50	110	
P116B014/50	50	40	84		P116B020/35	35	45	100		P116B025/35	35	50	110	
P116B015/25	25	40	92		P116B020/38	38	45	100		P116B025/38	38	50	110	
P116B015/28	28	40	92		P116B020/40	40	45	100		P116B025/40	40	50	110	
P116B015/30	30	40	92	P116B020/42	42	45	100	P116B025/42	42	50	110			
P116B015/32	32	40	92	P116B020/45	45	45	100	P116B025/45	45	50	110			
P116B015/35	35	40	92	P116B020/48	48	45	100	P116B025/48	48	50	110			
P116B015/38	38	40	92	P116B020/50	50	45	100	P116B025/50	50	50	110			
P116B015/40	40	40	92	21	P116B021/25	25	50	110						
P116B015/42	42	40	92		P116B021/28	28	50	110						
P116B015/45	45	40	92		P116B021/30	30	50	110						
P116B015/48	48	40	92		P116B021/32	32	50	110						
P116B015/50	50	40	92		P116B021/35	35	50	110						
P116B016/25	25	45	100		P116B021/38	38	50	110						
P116B016/28	28	45	100		P116B021/40	40	50	110						
P116B016/30	30	45	100	P116B021/42	42	50	110							
P116B016/32	32	45	100	P116B021/45	45	50	110							
P116B016/35	35	45	100	P116B021/48	48	50	110							
P116B016/38	38	45	100	P116B021/50	50	50	110							
P116B016/40	40	45	100											
P116B016/42	42	45	100											
P116B016/45	45	45	100											
P116B016/48	48	45	100											
P116B016/50	50	45	100											

MONTAGEFERTIGE KETTENRÄDER 20B

r	C	B1
32	3,5	18,5

TEILUNG: 1"1/4" x 3/14"
TEILUNG: 31,75 x 19,56 mm
MATERIAL: C45



Kettenrad mit einseitiger Nabe für Einfachrollenkettens laut folgenden Normen: DIN 8187 - ISO 606. Montagefertig mit H7 Bohrung, Keilnut JS9 in der Achse eines Zahns, zwei um 90° versetzte Gewindebohrungen und induktionsgehärtete Verzahnungen 45/53 HRC.

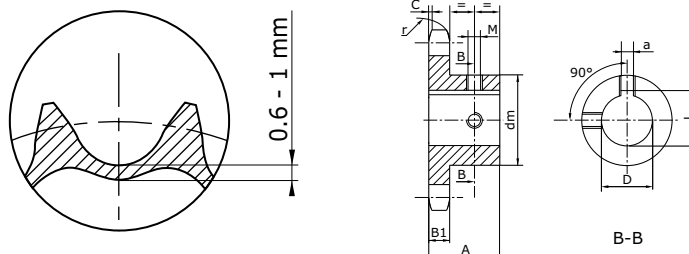

Für Abmessungen a, L und M siehe Tabelle Seite 103

Abmessungen in mm

Z	Art. Nr.	D	A	dm
9	P120B009/25	25	40	63
	P120B009/30	30	40	63
	P120B009/32	32	40	63
	P120B009/35	35	40	63
	P120B009/38	38	40	63
	P120B010/25	25	40	70
10	P120B010/30	30	40	70
	P120B010/32	32	40	70
	P120B010/35	35	40	70
	P120B010/38	38	40	70
11	P120B011/25	25	45	77
	P120B011/28	28	45	77
	P120B011/30	30	45	77
	P120B011/32	32	45	77
	P120B011/34	34	45	77
	P120B011/35	35	45	77
	P120B011/38	38	45	77
	P120B011/40	40	45	77
	P120B011/42	42	45	77
	P120B011/45	45	45	77
	P120B011/50	50	45	82
	P120B011/60	60	45	93
12	P120B012/25	25	45	88
	P120B012/28	28	45	88
	P120B012/30	30	45	88
	P120B012/32	32	45	88
	P120B012/35	35	45	88
	P120B012/38	38	45	88
	P120B012/40	40	45	88
	P120B012/42	42	45	88
	P120B012/45	45	45	88
	P120B012/48	48	45	88
	P120B012/50	50	45	88
	P120B012/60	60	45	93
13	P120B013/25	25	45	98
	P120B013/28	28	45	98
	P120B013/30	30	45	98
	P120B013/32	32	45	98
	P120B013/35	35	45	98
	P120B013/38	38	45	98
	P120B013/40	40	45	98
	P120B013/42	42	45	98
	P120B013/45	45	45	98
	P120B013/48	48	45	98
	P120B013/50	50	45	98
	P120B013/60	60	45	98

Z	Art. Nr.	D	A	dm
14	P120B014/32	32	45	108
	P120B014/35	35	45	108
	P120B014/38	38	45	108
	P120B014/40	40	45	108
	P120B014/42	42	45	108
	P120B014/45	45	45	108
15	P120B014/48	48	45	108
	P120B014/50	50	45	108
	P120B014/60	60	45	108
	P120B014/70	70	45	108
	P120B015/32	32	45	118
	P120B015/35	35	45	118
	P120B015/38	38	45	118
	P120B015/40	40	45	118
	P120B015/42	42	45	118
	P120B015/45	45	45	118
	P120B015/48	48	45	118
	P120B015/50	50	45	118
16	P120B015/60	60	45	118
	P120B016/38	38	50	120
	P120B016/40	40	50	120
	P120B016/42	42	50	120
	P120B016/45	45	50	120
	P120B016/48	48	50	120
	P120B016/50	50	50	120
	P120B016/60	60	50	120
	P120B016/65	65	50	120
	P120B016/70	70	50	120
	P120B017/25	25	50	120
	P120B017/28	28	50	120
17	P120B017/30	30	50	120
	P120B017/32	32	50	120
	P120B017/35	35	50	120
	P120B017/38	38	50	120
	P120B017/40	40	50	120
	P120B017/42	42	50	120
	P120B017/45	45	50	120
	P120B017/48	48	50	120
	P120B017/50	50	50	120
	P120B017/60	60	50	120
	P120B017/65	65	50	120
	P120B017/70	70	50	120

Z	Art. Nr.	D	A	dm
18	P120B018/38	38	50	120
	P120B018/40	40	50	120
	P120B018/42	42	50	120
	P120B018/45	45	50	120
	P120B018/48	48	50	120
	P120B018/50	50	50	120
19	P120B018/60	60	50	120
	P120B018/65	65	50	120
	P120B018/70	70	50	120
	P120B019/38	38	50	120
	P120B019/40	40	50	120
	P120B019/42	42	50	120
	P120B019/45	45	50	120
	P120B019/48	48	50	120
	P120B019/50	50	50	120
	P120B019/60	60	50	120
	P120B019/65	65	50	120
	P120B019/70	70	50	120
20	P120B020/38	38	50	120
	P120B020/40	40	50	120
	P120B020/42	42	50	120
	P120B020/45	45	50	120
	P120B020/48	48	50	120
	P120B020/50	50	50	120
	P120B020/60	60	50	120
	P120B020/65	65	50	120
P120B020/70	70	50	120	



KETTENRÄDER, KETTENRADSCHLEIBEN UND GUSSRÄDER

Abmessungen in mm

VORGEBOHRTE ZWEIFACH KETTENRADSCHLEIBEN FÜR 2 EINFACH ROLLENKETTEN

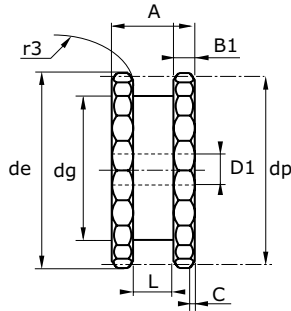

B1	C	r3
5,3	1	10

06B - Teilung: 3/8" x 7/32" - Teilung: 9,525 x 5,72 mm

Z	Art. Nr.	de	dp	D1	dg	A	L	Kg
13	D2S06B013	43,00	39,80	10	28	24,3	13,7	0,14
14	D2S06B014	46,30	42,80	10	31	24,3	13,7	0,17
15	D2S06B015	49,30	45,81	10	34	24,3	13,7	0,20
16	D2S06B016	52,30	48,82	10	37	24,3	13,7	0,23
17	D2S06B017	55,30	51,83	10	40	24,3	13,7	0,26
18	D2S06B018	58,30	54,85	10	43	24,3	13,7	0,30
19	D2S06B019	61,30	57,87	10	46	24,3	13,7	0,34
20	D2S06B020	64,30	60,89	10	49	24,3	13,7	0,38
21	D2S06B021	68,00	63,91	12	52	24,3	13,7	0,43
23	D2S06B023	73,50	69,95	12	59	24,3	13,7	0,54
25	D2S06B025	80,00	76,00	12	65	24,3	13,7	0,65

Doppelstahlscheiben für 2 Einfachrollenkettens laut folgenden Normen: DIN 8187 - ISO 606.

B1	C	r3
7,2	1,3	13

08B - Teilung: 1/2" x 5/16" - Teilung: 12,7 x 7,75 mm

Z	Art. Nr.	de	dp	D1	dg	A	L	Kg
12	D2S08B012	53,00	49,07	10	35	31	16,6	0,27
13	D2S08B013	57,40	53,06	10	37	31	16,6	0,33
14	D2S08B014	61,80	57,07	10	42	31	16,6	0,40
15	D2S08B015	65,50	61,09	10	45	31	16,6	0,47
16	D2S08B016	69,50	65,10	10	49	31	16,6	0,55
17	D2S08B017	73,60	69,11	12	53	31	16,6	0,64
18	D2S08B018	77,80	73,14	12	57	31	16,6	0,73
19	D2S08B019	81,70	77,16	12	62	31	16,6	0,84
20	D2S08B020	85,80	81,19	12	66	31	16,6	0,93
21	D2S08B021	89,70	85,22	14	70	31	16,6	1,03
23	D2S08B023	98,20	93,27	14	78	31	16,6	1,28
25	D2S08B025	105,80	101,33	14	86	31	16,6	1,54

B1	C	r3
9,1	1,6	16

10B - Teilung: 5/8" x 3/8" - Teilung: 15,875 x 9,65 mm

Z	Art. Nr.	de	dp	D1	dg	A	L	Kg
12	D2S10B012	68,00	61,34	12	45	36,5	18,1	0,51
13	D2S10B013	73,00	66,32	12	50	36,5	18,1	0,62
14	D2S10B014	78,00	71,34	12	55	36,5	18,1	0,74
15	D2S10B015	83,00	76,36	12	60	36,5	18,1	0,87
16	D2S10B016	88,00	81,37	12	65	36,5	18,1	1,02
17	D2S10B017	93,00	86,39	14	70	36,5	18,1	1,17
18	D2S10B018	98,30	91,42	14	75	36,5	18,1	1,34
19	D2S10B019	103,30	96,45	14	80	36,5	18,1	1,49
20	D2S10B020	108,40	101,49	14	85	36,5	18,1	1,68
21	D2S10B021	113,40	106,52	16	90	36,5	18,1	1,88
23	D2S10B023	123,50	116,58	16	100	36,5	18,1	2,30
25	D2S10B025	134,00	126,66	16	110	36,5	18,1	2,77

B1	C	r3
11,2	2	19

12B - Teilung: 3/4" x 7/16" - Teilung: 19,05 x 11,68 mm

Z	Art. Nr.	de	dp	D1	dg	A	L	Kg
12	D2S12B012	81,50	73,60	14	53	45	22,8	0,91
13	D2S12B013	87,50	79,59	14	59	45	22,8	1,12
14	D2S12B014	93,50	85,61	14	65	45	22,8	1,33
15	D2S12B015	99,50	91,63	14	71	45	22,8	1,57
16	D2S12B016	105,50	97,65	14	77	45	22,8	1,84
17	D2S12B017	111,50	103,67	16	83	45	22,8	2,12
18	D2S12B018	118,00	109,71	16	89	45	22,8	2,42
19	D2S12B019	124,20	115,75	16	95	45	22,8	2,75
20	D2S12B020	129,70	121,78	16	101	45	22,8	3,09
21	D2S12B021	136,00	127,82	20	107	45	22,8	3,42
23	D2S12B023	149,00	139,90	20	119	45	22,8	4,21
25	D2S12B025	160,00	152,00	20	131	45	22,8	5,07

B1	C	r3
16,2	2,5	26

16B - Teilung: 1" x 17,02 - Teilung: 25,4 x 17,02 mm

Z	Art. Nr.	de	dp	D1	dg	A	L	Kg
12	D2S16B012	109,00	98,14	16	73	63,5	31,1	2,58
13	D2S16B013	117,00	106,12	16	81	63,5	31,1	3,14
14	D2S16B014	125,00	114,15	16	89	63,5	31,1	3,76
15	D2S16B015	133,00	122,17	16	97	63,5	31,1	4,44
16	D2S16B016	141,00	130,20	20	105	63,5	31,1	5,09
17	D2S16B017	149,00	138,22	20	113	63,5	31,1	5,87
18	D2S16B018	157,00	146,28	20	121	63,5	31,1	6,70
19	D2S16B019	165,20	154,33	20	129	63,5	31,1	7,53
21	D2S16B021	181,20	170,43	20	145	63,5	31,1	9,48

TAPER LOCK KETTENRADSCHLEIBE FÜR 2 EINFACHROLLENKETTEN

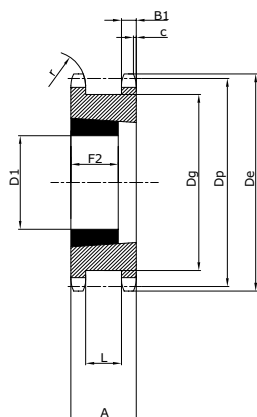

B1	C	r3
5,3	1	10

06B - Teilung: 3/8" x 7/32" - Teilung: 9,525 x 5,72 mm

Z	Art. Nr.	de	dp	D1 max.	dg	*für Klemmbuchsen	A	L	F2	Kg
18	D2SMA06B018	58,30	54,85	25	43	1008	23,5	12,9	22,2	0,19
19	D2SMA06B019	61,30	57,87	25	46	1008	23,5	12,9	22,2	0,23
20	D2SMA06B020	64,30	60,89	28	48	1108	23,5	12,9	22,2	0,25
21	D2SMA06B021	68,00	63,91	28	52	1108	23,5	12,9	22,2	0,31
23	D2SMA06B023	72,50	69,95	28	58	1108	23,5	12,9	22,2	0,4
25	D2SMA06B025	80,00	76,00	28	64	1108	23,5	12,9	22,2	0,53

Taper Lock Kettenradschleibe für 2 Einfachrollenkettens
DIN 8187 – ISO 606

B1	C	r3
7,2	1,3	13

08B - Teilung: 1/2" x 5/16" - Teilung: 12,7 x 7,75 mm

Z	Art. Nr.	de	dp	D1 max.	dg	*für Klemmbuchsen	A	L	F2	Kg
15	D2SMA08B015	65,50	61,09	25	45	1008	31	16,6	22,2	0,36
16	D2SMA08B016	69,50	65,10	28	49	1108	31	16,6	22,2	0,43
17	D2SMA08B017	73,60	69,11	28	53	1108	31	16,6	22,2	0,39
18	D2SMA08B018	77,80	73,14	32	58	1210	31	16,6	22,2	0,48
19	D2SMA08B019	81,70	77,16	32	62	1210	31	16,6	22,2	0,58
20	D2SMA08B020	85,80	81,19	32	66	1210	31	16,6	22,2	0,65
21	D2SMA08B021	89,70	85,22	42	70	1610	31	16,6	22,2	0,63
23	D2SMA08B023	98,20	93,27	42	78	1610	31	16,6	22,2	0,87
25	D2SMA08B025	105,80	101,33	50	86	2012	31	16,6	22,2	0,87

B1	C	r3
9,1	1,6	16

10B - Teilung: 5/8" x 3/8" - Teilung: 15,875 x 9,65 mm

Z	Art. Nr.	de	dp	D1 max.	dg	*für Klemmbuchsen	A	L	F2	Kg
12	D2SMA10B012	68,00	61,34	28	45	1108	36,5	18,1	22,2	0,42
13	D2SMA10B013	73,00	66,32	28	50	1108	36,5	18,1	22,2	0,53
14	D2SMA10B014	78,00	71,34	28	55	1108	36,5	18,1	22,2	0,67
15	D2SMA10B015	83,00	76,36	32	60	1210	36,5	18,1	25,4	0,64
16	D2SMA10B016	88,00	81,37	32	65	1210	36,5	18,1	25,4	0,81
17	D2SMA10B017	93,00	86,39	42	70	1610	36,5	18,1	25,4	0,80
18	D2SMA10B018	98,30	91,42	42	75	1610	36,5	18,1	25,4	0,98
19	D2SMA10B019	103,30	96,45	42	80	1610	36,5	18,1	25,4	1,17
20	D2SMA10B020	108,40	101,49	42	85	1610	36,5	18,1	25,4	1,36
21	D2SMA10B021	113,40	106,52	50	90	2012	36,5	18,1	31,8	1,24
23	D2SMA10B023	123,50	116,58	50	100	2012	36,5	18,1	31,8	1,69
25	D2SMA10B025	134,00	126,66	50	110	2012	36,5	18,1	31,8	2,20

B1	C	r3
11,2	2	19

12B - Teilung: 3/4" x 7/16" - Teilung: 19,05 x 11,68 mm

Z	Art. Nr.	de	dp	D1 max.	dg	*für Klemmbuchsen	A	L	F2	Kg
13	D2SMA12B013	87,50	79,59	32	59	1210	45	22,8	25,4	0,94
14	D2SMA12B014	93,50	85,61	32	65	1210	45	22,8	25,4	1,16
15	D2SMA12B015	99,50	91,63	42	71	1610	45	22,8	25,4	1,18
16	D2SMA12B016	105,50	97,65	42	77	1610	45	22,8	25,4	1,49
17	D2SMA12B017	111,50	103,67	42	83	1610	45	22,8	25,4	1,73
18	D2SMA12B018	118,00	109,71	50	89	2012	45	22,8	31,8	1,62
19	D2SMA12B019	124,20	115,75	50	95	2012	45	22,8	31,8	1,95
20	D2SMA12B020	129,70	121,78	65	101	2517	45	22,8	44,5	1,70
21	D2SMA12B021	136,00	127,82	65	107	2517	45	22,8	44,5	2,05
23	D2SMA12B023	149,00	139,90	65	119	2517	45	22,8	44,5	2,85
25	D2SMA12B025	160,00	152,00	65	131	2517	45	22,8	44,5	3,75

B1	C	r3
16,2	2,5	26

16B - Teilung: 1" x 17,02 mm - Teilung: 25,4 x 17,02 mm

Z	Art. Nr.	de	dp	D1 max.	dg	*für Klemmbuchsen	A	L	F2	Kg
12	D2SMA16B012	109,00	98,14	42	72	1615	63,5	31,1	38,1	1,90
13	D2SMA16B013	117,00	106,12	42	81	1615	63,5	31,1	38,1	2,50
14	D2SMA16B014	125,00	114,15	50	88	2012	63,5	31,1	31,8	2,50
15	D2SMA16B015	133,00	122,17	50	97	2012	63,5	31,1	31,8	3,10
16	D2SMA16B016	141,00	130,20	50	104	2012	63,5	31,1	31,8	3,75
17	D2SMA16B017	149,00	138,22	65	113	2517	63,5	31,1	44,5	3,90
18	D2SMA16B018	157,00	146,28	65	121	2517	63,5	31,1	44,5	4,70
19	D2SMA16B019	165,20	154,33	65	129	2517	63,5	31,1	44,5	5,50
20	D2SMA16B020	173,20	162,38	75	137	3020	63,5	31,1	50,8	5,15
21	D2SMA16B021	181,20	170,43	75	145	3020	63,5	31,1	50,8	6,05
23	D2SMA16B023	197,50	186,53	90	161	3525	63,5	31,1	63,5	7,20
25	D2SMA16B025	213,50	202,66	90	177	3525	63,5	31,1	63,5	9,40

*Taperbuchse nicht inkludiert



TECHNISCHE DATEN - ZAHNUNG IM MASSSTAB 1/1 - 100%

Bestimmung des max. \varnothing der Bohrung in Abhängigkeit vom \varnothing der Nabe (dm):

Für Stahl: $\varnothing_{max} = dm \times 0,7$

Für Guss: $\varnothing_{max} = dm \times 0,6$

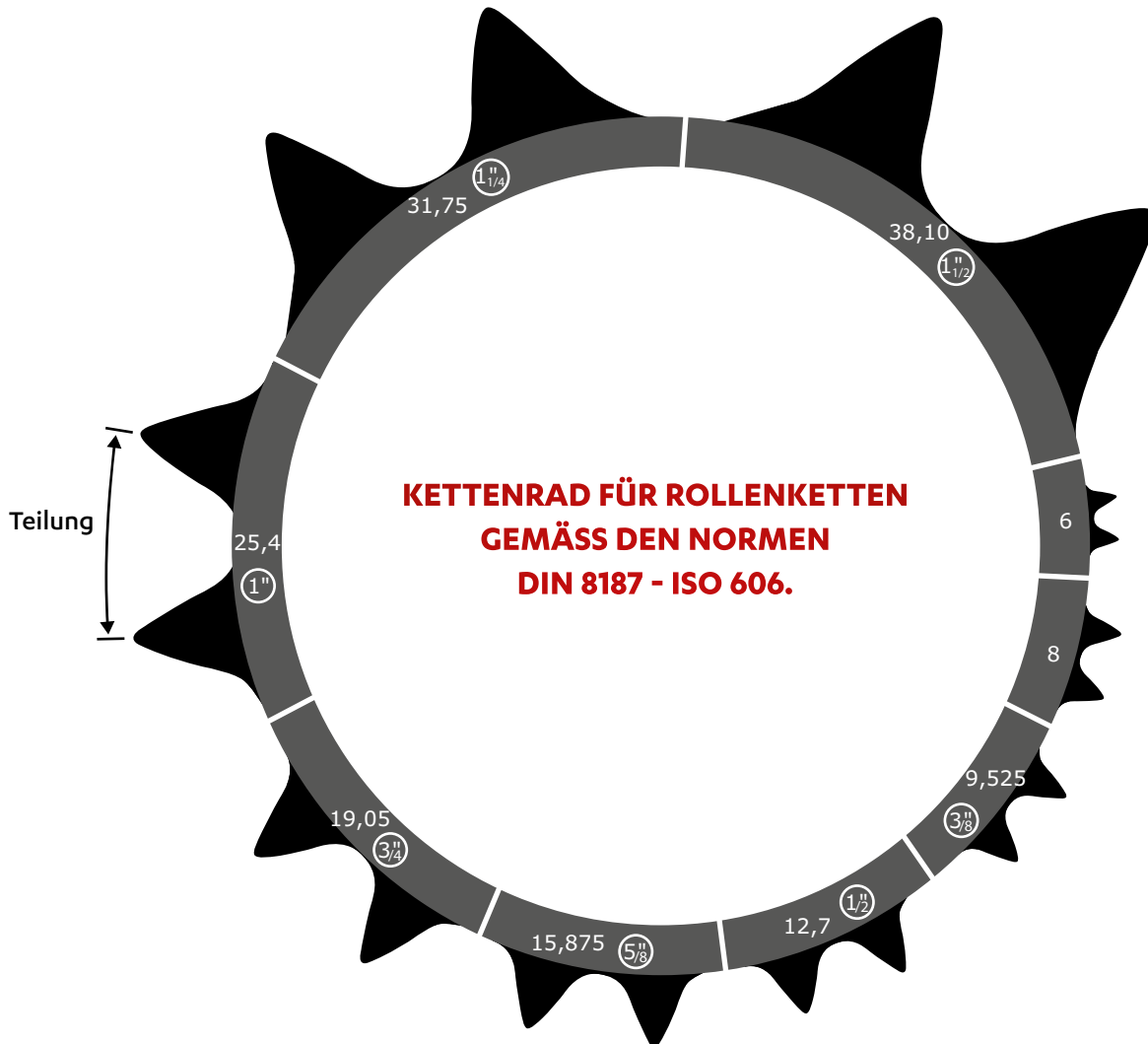

TYPISCHE ABMESSUNGEN VON KEILNUTEN

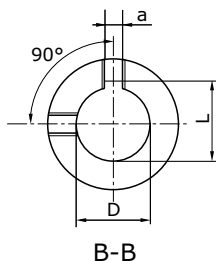
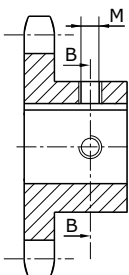

D (H7)	a	L	M	D (H7)	a	L	M
10	4	D + 1,8 (+0,1/0)	M3	30	8	D + 3,3 (+0,2/0)	M6
11	4	D + 1,8 (+0,1/0)	M3	32	10	D + 3,3 (+0,2/0)	M8
12	4	D + 1,8 (+0,1/0)	M3	35	10	D + 3,3 (+0,2/0)	M8
14	5	D + 2,3 (+0,1/0)	M4	38	10	D + 3,3 (+0,2/0)	M8
16	5	D + 2,3 (+0,1/0)	M4	40	12	D + 3,3 (+0,2/0)	M10
18	6	D + 2,8 (+0,1/0)	M5	42	12	D + 3,3 (+0,2/0)	M10
19	6	D + 2,8 (+0,1/0)	M5	45	14	D + 3,8 (+0,2/0)	M12
20	6	D + 2,8 (+0,1/0)	M5	48	14	D + 3,8 (+0,2/0)	M12
22	6	D + 2,8 (+0,1/0)	M5	50	14	D + 3,8 (+0,2/0)	M12
24	8	D + 3,3 (+0,2/0)	M6	60	18	D + 4,4 (+0,2/0)	M12
25	8	D + 3,3 (+0,2/0)	M6	65	18	D + 4,4 (+0,2/0)	M12
28	8	D + 3,3 (+0,2/0)	M6	70	20	D + 4,9 (+0,2/0)	M12

sedis 



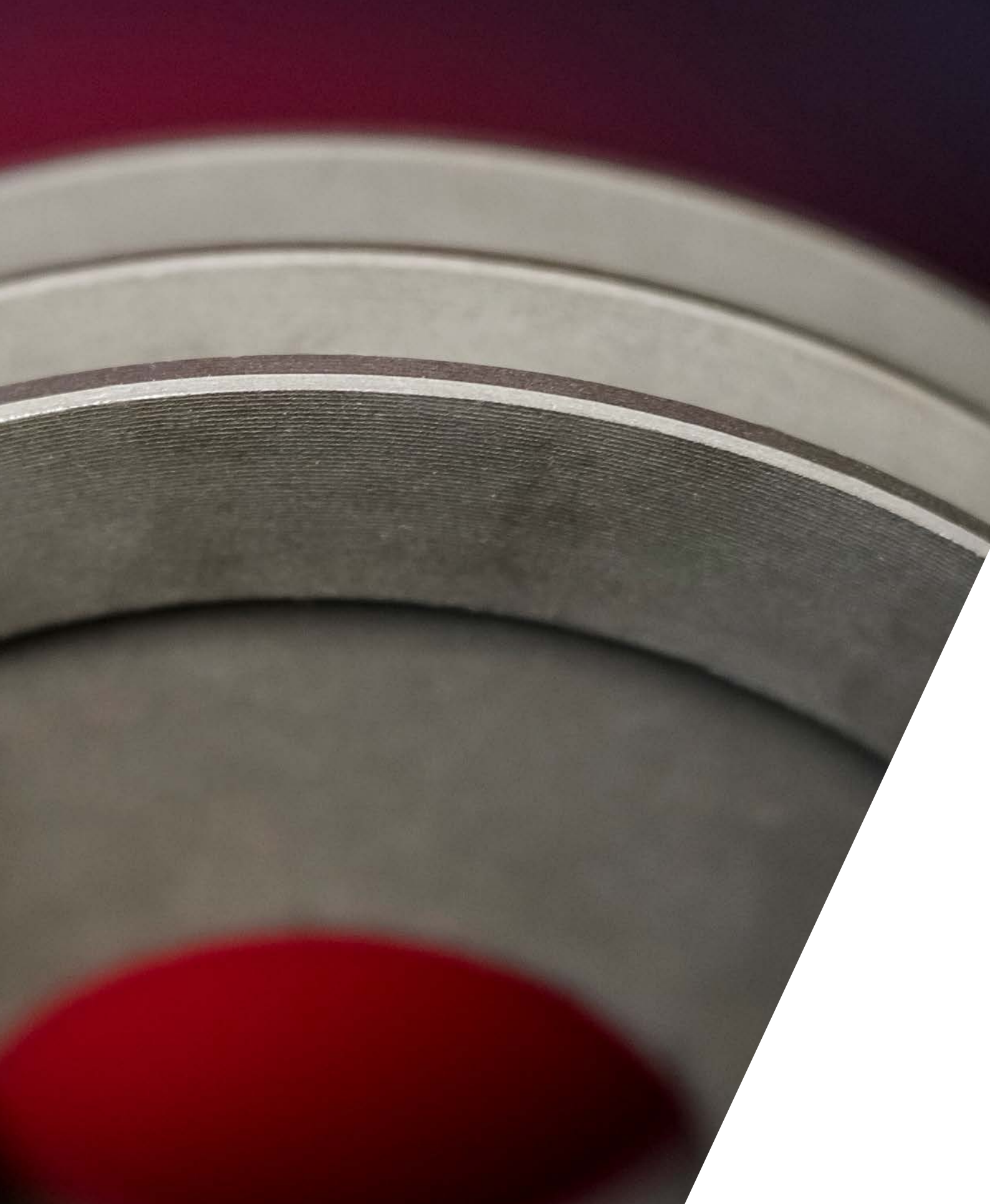

KEILRIEMENSCHLEIBEN

VERSTELLBARE KEILRIEMENSCHLEIBEN

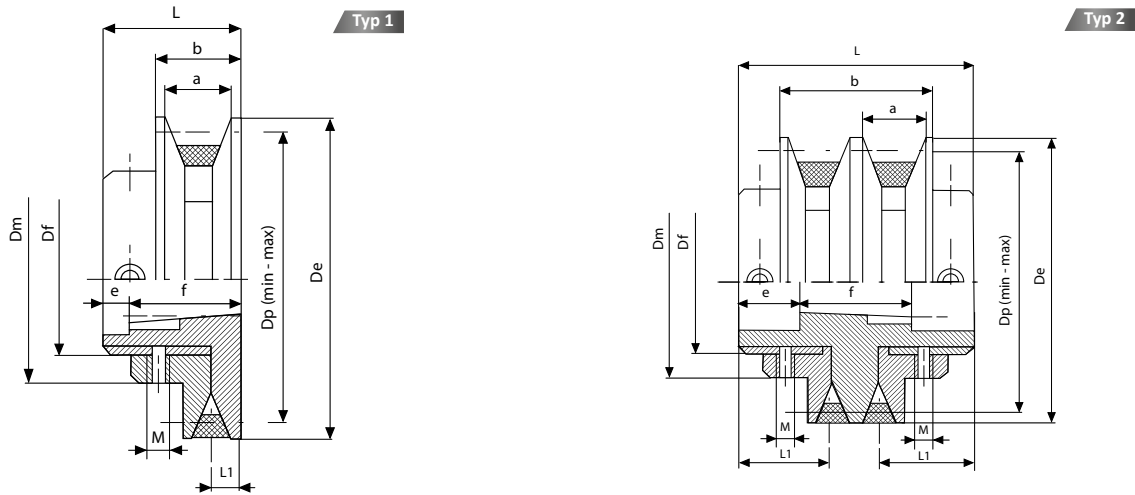

KEILRIEMENSCHLEIBE MIT VERSTELLBARER RILLENBREITE, GUSS PHOSPATIIERT

Art. Nr.	Typ	Buchse	De	Dm	Df	Dp		a		b		L1	e	f	M	L	Kg
						Max	Min	Max	Min	Max	Min						
SPZV084/1MA*	1	1108	84	65	50	80	62	14,5	10	19,5	15	7,5	-	28	6	28	0,50
SPZV095/1MA	1	1108	95	75	60	91	73	14,5	10	20,5	16	8	8	22	6	30	0,78
SPZV100/1MA	1	1108	100	75	60	96	78	14,5	10	20,5	16	8	8	22	6	30	0,85
SPZV108/1MA	1	1210	108	90	72	104	90	14,5	10	20,5	16	8	10	25	8	35	1,13
SPAV108/1MA*	1	1210	108	80	62	102	76	19,5	13	26,5	19	9,5	12	27	8	39	1,12
SPAV120/1MA	1	1210	120	91	72	114	88	19,5	13	26,5	20	10	10	26	8	36	1,42
SPAV120/2MA	2	1215	120	91	72	114	88	19,5	13	47,1	34	26	12	40,5	8	66	2,46
SPAV129/1MA	1	1210	129	91	72	123	97	19,5	13	26,5	20	10	10,2	26	8	36	1,67
SPAV/129/2MA	2	1215	129	91	72	123	97	19,5	13	47,1	34	26	12	40	8	66	2,83
SPAV139/1MA	1	1610	139	103	85	133	109	18,9	13	25,9	20	10	11	26	8	37	1,96
SPAV139/2MA	2	1615	139	103	85	133	109	18,9	13	46,8	35	26	14,5	38,5	8	69	3,37
SPAV146/1MA	1	1610	146	103	85	140	116	18,9	13	25,9	20	10	11	26	8	37	2,17
SPAV146/2MA	2	1615	146	103	85	140	116	18,9	13	46,8	35	27	14,5	38,5	8	69	3,77
SPAV156/1MA	1	1610	156	103	85	150	126	18,9	13	25,9	20	10	11	26	8	37	2,43
SPAV156/2MA	2	1615	156	103	85	150	126	18,9	13	46,8	35	27	14,5	38,5	8	69	4,25
SPAV164/1MA	1	1610	164	103	85	158	134	18,9	13	25,9	20	10	8	29	8	37	2,76
SPAV164/2MA	2	1615	164	103	85	158	134	18,9	13	46,8	35	27	15,5	37,5	8	69	4,74
SPAV177/1MA	1	2012	177	135	110	171	149	18,2	13	25,2	20	10	8	32	8	40	3,76
SPAV177/2MA	2	2012	177	135	110	171	149	18,2	13	45,5	35	27,5	24	37	8	90	6,80
SPAV187/1MA	1	2012	187	135	110	181	159	18,2	13	25,2	20	10	8	32	8	40	4,14
SPAV187/2MA	2	2012	187	135	110	181	159	18,2	13	45,5	35	37,5	24	37	8	90	7,50
SPBV178/1MA	1	2012	178	135	110	171	139	21,5	16	28,5	23	10	8	32	8	40	3,73
SPBV178/2MA	2	2012	178	135	110	171	139	22,5	16	54,5	42	37,5	24	37	8	90	6,75
SPBV187/1MA	1	2012	187	135	110	180	148	21,5	16	28,5	23	10	8	32	8	40	4,70
SPBV187/2MA	2	2012	187	135	110	180	148	22,5	16	54,5	42	37,5	24	37	8	90	7,35

* Montage der Taperlockbuchse von der anderen Seite, nicht wie im Schema



KEILRIEMENSCHLEIBEN MIT VOLLNABEN SPZ

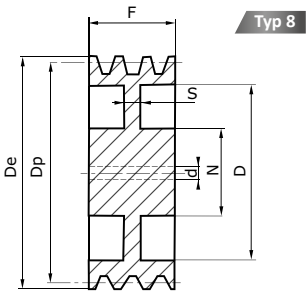
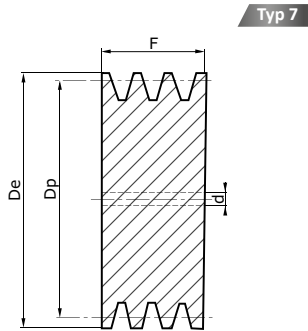
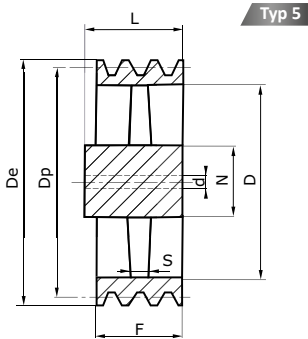
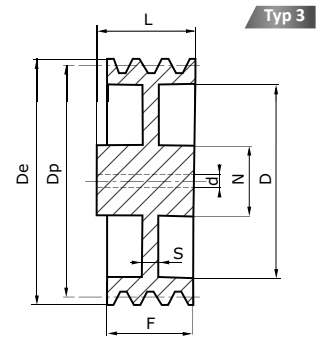
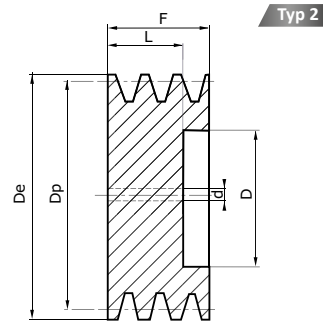
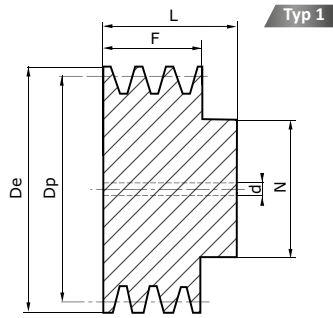

Art. Nr.	Dp	De	SPZ						Typ	d
			Z	N	L	D	S	F		
SPZ050/1			1	40	28	-	-	16	1	10
SPZ050/2	50	54	2	40	35	-	-	28	1	10
SPZ050/3			3	-	-	-	-	40	7	10
SPZ056/1			1	45	28	-	-	16	1	10
SPZ056/2	56	60	2	45	35	-	-	28	1	10
SPZ056/3			3	-	-	-	-	40	7	10
SPZ063/1			1	50	28	-	-	16	1	10
SPZ063/2	63	67	2	50	35	-	-	28	1	10
SPZ063/3			3	-	-	-	-	40	7	10
SPZ071/1			1	50	28	-	-	16	1	10
SPZ071/2	71	75	2	55	35	-	-	28	1	10
SPZ071/3			3	-	-	-	-	40	7	10
SPZ075/1			1	50	28	-	-	16	1	10
SPZ075/2	75	79	2	60	35	-	-	28	1	10
SPZ075/3			3	-	-	-	-	40	7	10
SPZ080/1			1	50	28	-	-	16	1	10
SPZ080/2	80	84	2	60	35	-	-	28	1	10
SPZ080/3			3	-	-	-	-	40	7	10
SPZ085/1			1	50	28	-	-	16	1	10
SPZ085/2	85	89	2	60	35	-	-	28	1	10
SPZ085/3			3	-	-	-	-	40	7	15
SPZ090/1			1	50	28	-	-	16	1	10
SPZ090/2	90	94	2	60	35	-	-	28	1	10
SPZ090/3			3	-	-	-	-	40	7	15
SPZ095/1			1	50	28	-	-	16	1	10
SPZ095/2	95	99	2	60	35	-	-	28	1	15
SPZ095/3			3	-	-	-	-	40	7	15
SPZ100/1			1	50	28	-	-	16	1	10
SPZ100/2	100	104	2	60	35	-	-	28	1	15
SPZ100/3			3	-	-	-	-	40	7	15
SPZ106/1			1	50	28	-	-	16	1	10
SPZ106/2	106	110	2	60	35	-	-	28	1	15
SPZ106/3			3	-	-	-	-	40	7	15
SPZ112/1			1	50	28	-	-	16	1	10
SPZ112/2	112	116	2	60	35	-	-	28	1	15
SPZ112/3			3	-	-	-	-	40	7	15
SPZ118/1			1	50	28	93	8	16	3	10
SPZ118/2	118	122	2	60	35	91	8	28	3	15
SPZ118/3			3	-	-	-	-	40	7	15
SPZ125/1			1	50	28	100	8	16	3	15
SPZ125/2	125	129	2	60	35	99	8	28	3	15
SPZ125/3			3	-	-	-	-	40	7	15
SPZ132/1			1	50	28	106	8	16	3	15
SPZ132/2	132	136	2	60	40	106	8	28	3	15
SPZ132/3			3	60	40	106	8	40	8	15
SPZ140/1			1	50	28	114	8	16	3	15
SPZ140/2	140	144	2	60	40	114	8	28	3	15
SPZ140/3			3	60	40	114	8	40	8	15
SPZ150/1			1	50	28	124	8	16	3	15
SPZ150/2	150	154	2	60	40	124	8	28	3	15
SPZ150/3			3	60	40	124	8	40	8	20
SPZ160/1			1	55	32	134	8	16	3	15
SPZ160/2	160	164	2	60	40	134	8	28	3	15
SPZ160/3			3	65	45	134	8	40	3	20
SPZ180/1			1	55	32	154	8	16	5	20
SPZ180/2	180	184	2	60	40	154	8	28	5	20
SPZ180/3			3	65	45	154	8	40	5	20
SPZ200/1			1	55	32	174	8	16	5	20
SPZ200/2	200	204	2	60	40	174	8	28	5	20
SPZ200/3			3	65	45	174	10	40	5	20
SPZ224/1			1	55	32	198	8	16	5	20
SPZ224/2	224	228	2	60	40	198	8	28	5	20
SPZ224/3			3	65	45	198	10	40	5	20
SPZ250/1			1	55	32	224	8	16	5	20
SPZ250/2	250	254	2	60	40	224	10	28	5	20
SPZ250/3			3	65	45	224	12	40	5	20
SPZ280/2	280	284	2	65	45	254	10	28	5	20
SPZ315/2	315	319	2	65	45	289	10	28	5	20

Z = Anzahl der Rillen



KEILRIEMENSCHLEIBEN MIT VOLLNABEN SPA

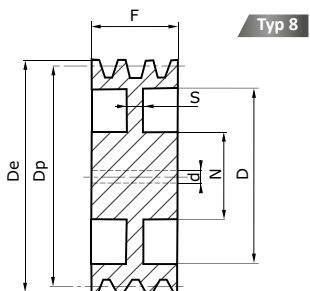
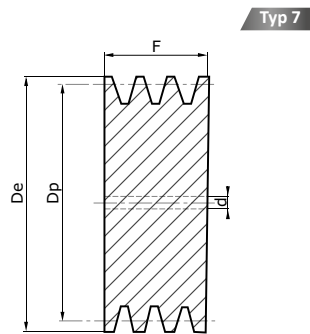
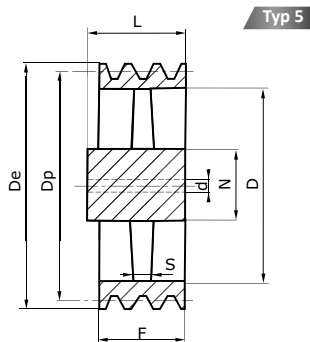
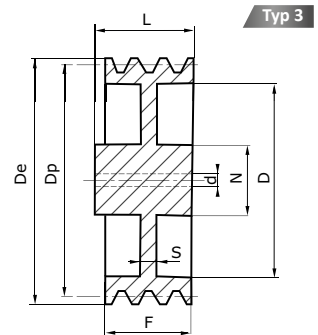
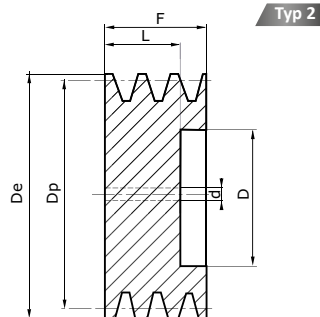
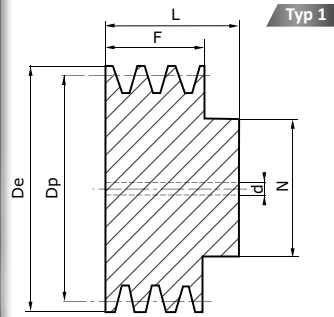

SPA											
Art. Nr.	Dp	De	Z	N	L	D	S	F	Typ	d	
SPA040/1	40	45,5	1	40	35	-	-	20	1	10	
SPA050/1	50	55,5	1	40	35	-	-	20	1	10	
SPA050/2			2	40	45	-	-	35	1	10	
SPA063/1	63	68,5	1	40	35	-	-	20	1	10	
SPA063/2			2	40	45	-	-	35	1	10	
SPA063/3			3	-	-	-	-	50	7	10	
SPA071/1	71	76,5	1	40	40	-	-	20	1	10	
SPA071/2			2	50	45	-	-	35	1	10	
SPA071/3			3	-	-	-	-	50	7	10	
SPA075/1	75	80,5	1	40	40	-	-	20	1	10	
SPA075/2			2	50	45	-	-	35	1	10	
SPA075/3			3	-	-	-	-	50	7	10	
SPA075/4			4	-	-	-	-	65	7	10	
SPA075/5			5	-	-	-	-	80	7	10	
SPA080/1	80	85,5	1	45	40	-	-	20	1	10	
SPA080/2			2	50	45	-	-	35	1	10	
SPA080/3			3	-	-	-	-	50	7	15	
SPA080/4			4	-	-	-	-	65	7	15	
SPA080/5			5	-	-	-	-	80	7	15	
SPA085/1	85	90,5	1	45	40	-	-	20	1	10	
SPA085/2			2	50	45	-	-	35	1	10	
SPA085/3			3	-	-	-	-	50	7	15	
SPA085/4			4	-	-	-	-	65	7	15	
SPA085/5			5	-	-	-	-	80	7	15	
SPA090/1	90	95,5	1	45	40	-	-	20	1	10	
SPA090/2			2	60	45	-	-	35	1	15	
SPA090/3			3	-	-	-	-	50	7	15	
SPA090/4			4	-	-	-	-	65	7	15	
SPA090/5			5	-	-	-	-	80	7	15	
SPA095/1	95	100,5	1	45	40	-	-	20	1	10	
SPA095/2			2	60	45	-	-	35	1	15	
SPA095/3			3	-	-	-	-	50	7	15	
SPA095/4			4	-	-	-	-	65	7	15	
SPA095/5			5	-	-	-	-	80	7	15	
SPA100/1	100	105,5	1	48	40	-	-	20	1	10	
SPA100/2			2	60	45	-	-	35	1	15	
SPA100/3			3	-	-	-	-	50	7	15	
SPA100/4			4	-	-	52	67	-	65	2	15
SPA100/5			5	-	-	52	67	-	80	2	15
SPA106/1	106	111,5	1	48	40	-	-	20	1	10	
SPA106/2			2	60	45	-	-	35	1	15	
SPA112/1			1	48	40	-	-	20	1	10	
SPA112/2	112	117,5	2	60	45	-	-	35	1	15	
SPA112/3			3	-	-	-	-	50	7	15	
SPA112/4			4	-	-	52	79	-	65	2	15
SPA112/5	5	-	-	52	79	-	80	2	15		
SPA118/1	118	123,5	1	60	40	-	-	20	1	15	
SPA118/2			2	60	45	-	-	35	1	15	
SPA118/3			3	-	-	-	-	50	7	15	
SPA118/4			4	-	-	52	87	-	65	2	15
SPA118/5			5	-	-	52	87	-	80	2	15

Z = Anzahl der Rillen



KEILRIEMENSCHLEIBEN MIT VOLLNABEN SPA

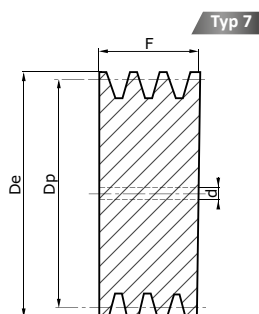
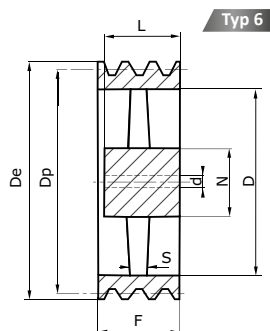
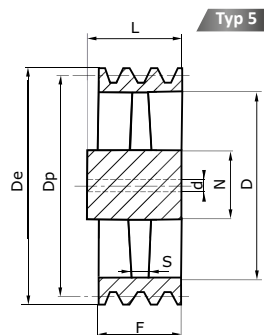
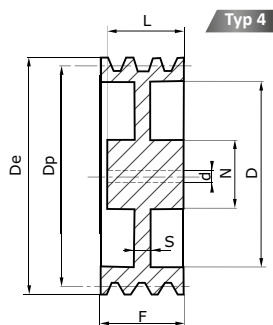
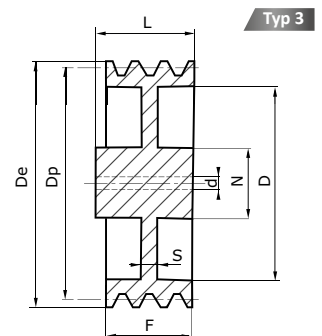
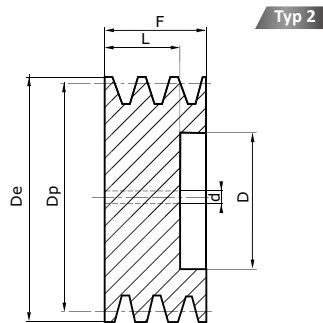
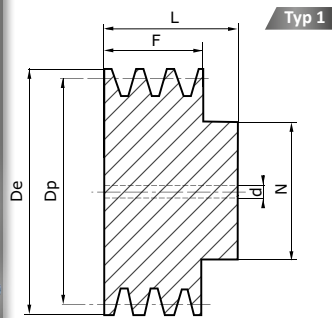
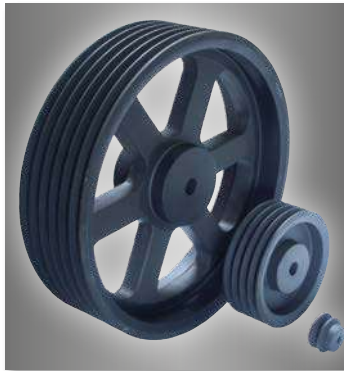

SPA										
Art. Nr.	Dp	De	Z	N	L	D	S	F	Typ	d
SPA132/1			1	60	40	-	-	20	1	15
SPA132/2			2	60	45	-	-	35	1	15
SPA132/3	132	137,5	3	-	-	-	-	50	7	15
SPA132/4			4	-	52	97	-	65	2	15
SPA132/5			5	-	52	97	-	80	2	15
SPA140/1			1	60	40	107	10	20	3	15
SPA140/2			2	60	45	107	10	35	3	15
SPA140/3	140	145,5	3	65	52	107	18	50	3	20
SPA140/4			4	-	52	107	-	65	2	20
SPA140/5			5	-	52	107	-	80	2	20
SPA150/1			1	60	40	117	10	20	3	15
SPA150/2			2	60	45	117	10	35	3	15
SPA150/3	150	155,5	3	65	52	117	18	50	3	20
SPA150/4			4	-	52	117	-	65	2	20
SPA150/5			5	-	52	117	-	80	2	20
SPA160/1			1	60	40	127	10	20	3	15
SPA160/2			2	60	45	127	10	35	3	15
SPA160/3	160	165,5	3	70	52	127	18	50	3	20
SPA160/4			4	70	52	127	22	65	4	20
SPA160/5			5	80	52	127	22	80	4	20
SPA170/1			1	60	40	137	10	20	3	15
SPA170/2			2	60	45	137	10	35	3	15
SPA170/3	170	175,5	3	70	52	137	18	50	3	20
SPA170/4			4	80	52	137	18	65	4	20
SPA170/5			5	80	52	137	18	80	4	20
SPA180/1			1	65	40	147	10	20	3	20
SPA180/2			2	70	50	147	12	35	3	20
SPA180/3	180	185,5	3	70	52	147	12	50	3	20
SPA180/4			4	80	60	147	22	65	4	20
SPA180/5			5	80	65	147	22	80	4	20
SPA200/1			1	65	45	167	10	20	3	20
SPA200/2			2	70	50	167	12	35	3	20
SPA200/3	200	205,5	3	70	52	167	12	50	3	20
SPA200/4			4	80	60	167	18	65	4	20
SPA200/5			5	80	65	167	20	80	4	20
SPA224/1			1	65	45	192	10	20	3	20
SPA224/2			2	70	50	192	12	35	3	20
SPA224/3	224	229,5	3	80	52	192	12	50	3	20
SPA224/4			4	90	60	192	18	65	4	20
SPA224/5			5	90	65	192	20	80	4	20
SPA250/1			1	75	50	217	12	20	3	20
SPA250/2			2	75	50	217	12	35	3	20
SPA250/3	250	255,5	3	80	60	217	12	50	3	20
SPA250/4			4	90	65	217	18	65	3	20
SPA250/5			5	90	65	217	20	80	4	20
SPA280/1			1	75	50	247	14	20	5	20
SPA280/2			2	80	50	247	14	35	5	20
SPA280/3	280	285,5	3	80	60	247	14	50	5	20
SPA280/4			4	90	65	247	16	65	5	20
SPA280/5			5	100	65	247	18	80	6	25

SPA										
Art. Nr.	Dp	De	Z	N	L	D	S	F	Typ	d
SPA300/1			1	75	50	267	14	20	5	20
SPA300/2			2	80	50	267	14	35	5	20
SPA300/3	300	305,5	3	80	60	267	14	50	5	20
SPA300/4			4	90	65	267	16	65	5	20
SPA300/5			5	100	65	267	18	80	6	25
SPA315/1			1	75	50	282	14	20	5	20
SPA315/2			2	80	50	282	14	35	5	20
SPA315/3	315	320,5	3	90	60	282	14	50	5	20
SPA315/4			4	90	65	282	16	65	5	20
SPA315/5			5	100	65	282	18	80	6	25
SPA355/1			1	75	50	322	14	20	5	20
SPA355/2			2	80	50	322	14	35	5	20
SPA355/3	355	360,5	3	90	60	322	14	50	5	20
SPA355/4			4	90	65	322	16	65	5	25
SPA355/5			5	100	65	322	18	80	6	25
SPA400/1			1	90	50	367	14	20	5	20
SPA400/2			2	90	50	367	14	35	5	20
SPA400/3	400	405,5	3	100	60	367	16	50	5	25
SPA400/4			4	100	65	367	20	65	5	25
SPA400/5			5	100	65	367	22	80	6	25
SPA450/1			1	90	50	417	14	20	5	20
SPA450/2			2	100	50	417	14	35	5	25
SPA450/3	450	455,5	3	100	60	417	16	50	5	25
SPA450/4			4	105	65	417	20	65	6	25
SPA450/5			5	105	65	417	22	80	6	25
SPA500/1			1	90	50	467	14	20	5	20
SPA500/2			2	100	50	467	16	35	5	25
SPA500/3	500	505,5	3	105	60	467	20	50	5	25
SPA500/4			4	105	65	467	20	65	6	25
SPA500/5			5	110	65	467	22	80	6	25
SPA560/1			1	100	50	527	15	20	5	25
SPA560/2			2	100	50	527	18	35	5	25
SPA560/3			3	120	65	527	20	50	5	25
SPA560/4	560	565,5	4	120	65	527	22	65	5	25
SPA560/5			5	120	80	527	24	80	5	25
SPA560/6			6	120	80	527	26	95	6	25
SPA600/1			1	100	50	567	16	20	5	25
SPA600/2			2	110	50	567	18	35	5	25
SPA600/3			3	120	65	567	20	50	5	25
SPA600/4	600	605,5	4	120	65	567	22	65	5	25
SPA600/5			5	120	80	567	24	80	5	25
SPA600/6			6	120	80	567	26	95	6	25
SPA630/1			1	100	50	597	16	20	5	25
SPA630/2			2	110	50	597	18	35	5	25
SPA630/3			3	120	65	597	20	50	5	25
SPA630/4	630	635,5	4	120	65	597	22	65	5	25
SPA630/5			5	120	80	597	24	80	5	25
SPA630/6			6	120	80	597	26	95	6	25

Z = Anzahl der Rillen



KEILRIEMENSCHLEIBEN MIT VOLLNABEN SPB

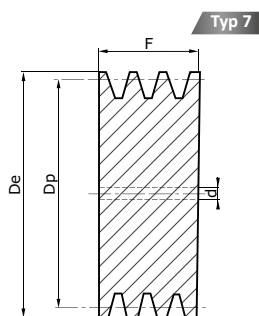
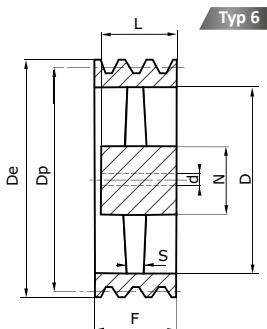
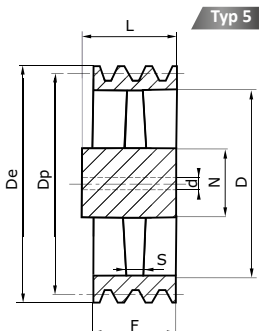
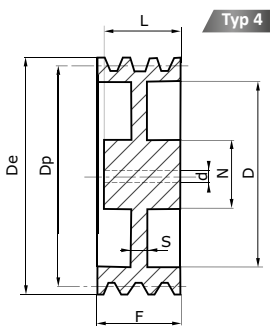
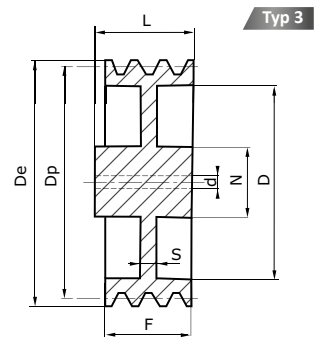
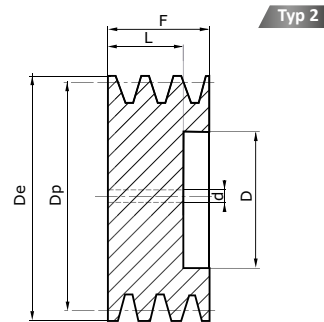
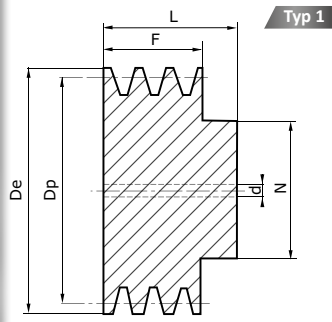
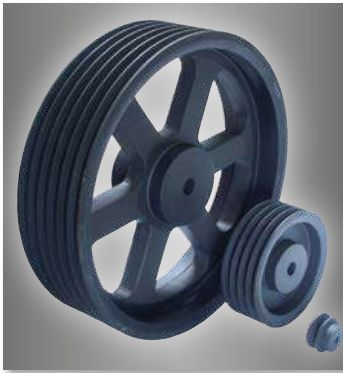

SPB										
Art. Nr.	Dp	De	Z	N	L	D	S	F	Typ	d
SPB070/1	70	77	1	45	45	-	-	25	1	10
SPB070/2			2	45	55	-	-	44	1	10
SPB080/1			1	50	45	-	-	25	1	10
SPB080/2			2	50	55	-	-	44	1	10
SPB080/3			3	-	-	-	-	63	7	15
SPB080/4			4	-	-	-	-	82	7	15
SPB080/5			5	-	-	-	-	101	7	15
SPB090/1			1	50	45	-	-	25	1	10
SPB090/2			2	50	55	-	-	44	1	10
SPB090/3			3	-	-	-	-	63	7	15
SPB090/4			4	-	-	-	-	82	7	15
SPB090/5			5	-	-	-	-	101	7	15
SPB100/1			1	52	45	-	-	25	1	10
SPB100/2			2	55	55	-	-	44	1	10
SPB100/3			3	-	-	-	-	63	7	15
SPB100/4			4	-	-	-	-	82	7	15
SPB100/5			5	-	-	-	-	101	7	15
SPB112/1			1	55	45	-	-	25	1	15
SPB112/2			2	60	55	-	-	44	1	15
SPB112/3			3	-	-	-	-	63	7	15
SPB112/4			4	-	-	-	-	82	7	20
SPB112/5			5	-	-	-	-	101	7	20
SPB118/1			1	55	45	-	-	25	1	15
SPB118/2			2	60	55	-	-	44	1	15
SPB118/3			3	-	-	-	-	63	7	15
SPB118/4			4	-	-	-	-	82	7	20
SPB118/5			5	-	-	-	-	101	7	20
SPB118/6			6	-	-	-	-	120	7	20
SPB125/1			1	58	45	-	-	25	1	15
SPB125/2			2	60	55	-	-	44	1	15
SPB125/3			3	-	60	83	-	63	2	15
SPB125/4			4	-	60	83	-	82	2	20
SPB125/5			5	-	60	83	-	101	2	20
SPB125/6			6	-	60	83	-	120	2	20
SPB132/1			1	60	45	-	-	25	1	15
SPB132/2			2	60	55	-	-	44	1	15
SPB132/3			3	-	60	88	-	63	2	15
SPB132/4			4	-	60	88	-	82	2	20
SPB132/5			5	-	60	88	-	101	2	20
SPB132/6			6	-	60	88	-	120	2	20
SPB140/1			1	65	45	-	-	25	1	20
SPB140/2			2	65	55	-	-	44	1	20
SPB140/3			3	-	60	98	-	63	2	20
SPB140/4			4	-	60	98	-	82	2	20
SPB140/5			5	-	60	98	-	101	2	20
SPB140/6			6	-	60	98	-	120	2	20
SPB150/1			1	65	45	-	-	25	1	20
SPB150/2			2	65	55	-	-	44	1	20
SPB150/3			3	-	60	108	-	63	2	20
SPB150/4			4	-	60	108	-	82	2	20
SPB150/5			5	-	60	108	-	101	2	20
SPB150/6			6	-	60	108	-	120	2	20

Z = Anzahl der Rillen

SPB										
Art. Nr.	Dp	De	Z	N	L	D	S	F	Typ	d
SPB160/1			1	65	45	118	12	25	3	20
SPB160/2			2	70	55	118	12	44	3	20
SPB160/3			3	-	60	118	-	63	2	20
SPB160/4			4	-	60	118	-	82	2	20
SPB160/5			5	-	60	118	-	101	2	20
SPB160/6			6	-	65	118	-	120	2	20
SPB170/1			1	65	45	128	12	25	3	20
SPB170/2			2	70	55	128	12	44	3	20
SPB170/3			3	70	60	128	30	63	4	20
SPB170/4			4	70	60	128	30	82	4	20
SPB170/5			5	70	60	128	30	101	4	20
SPB170/6			6	70	65	128	40	120	4	20
SPB180/1			1	65	45	138	12	25	3	20
SPB180/2			2	70	55	138	12	44	3	20
SPB180/3			3	80	60	138	18	63	4	20
SPB180/4			4	80	60	138	30	82	4	20
SPB180/5			5	80	70	138	40	101	4	20
SPB180/6			6	80	70	138	40	120	4	20
SPB200/1			1	70	45	158	14	25	3	20
SPB200/2			2	70	55	158	12	44	3	20
SPB200/3			3	80	60	158	18	63	4	20
SPB200/4			4	88	60	158	25	82	4	20
SPB200/5			5	96	70	158	35	101	4	25
SPB200/6			6	96	70	158	40	120	4	25
SPB212/1			1	70	45	170	14	25	3	20
SPB212/2			2	77	55	170	14	44	3	20
SPB212/3			3	80	60	170	18	63	4	20
SPB212/4			4	88	60	170	25	82	4	20
SPB212/5			5	96	70	170	30	101	4	25
SPB212/6			6	104	80	170	45	120	4	25
SPB225/1			1	70	45	183	14	25	3	20
SPB225/2			2	77	55	183	14	44	3	20
SPB225/3			3	80	60	183	18	63	4	20
SPB225/4			4	88	60	183	25	82	4	20
SPB225/5			5	96	70	183	35	101	4	25
SPB225/6			6	104	80	183	30	120	4	25
SPB250/1			1	70	50	208	14	25	3	20
SPB250/2			2	77	55	208	14	44	3	20
SPB250/3			3	80	60	208	18	63	4	20
SPB250/4			4	96	65	208	25	82	4	25
SPB250/5			5	104	75	208	35	101	4	25
SPB250/6			6	104	80	208	40	120	4	25
SPB280/1			1	76	50	238	14	25	3	20
SPB280/2			2	80	55	238	14	44	3	20
SPB280/3			3	90	60	238	18	63	4	20
SPB280/4			4	96	65	238	25	82	4	25
SPB280/5			5	104	75	238	35	101	4	25
SPB280/6			6	104	80	238	40	120	4	25
SPB300/1			1	76	50	258	15	25	5	20
SPB300/2			2	80	55	258	15	44	5	20
SPB300/3			3	90	60	258	18	63	6	20
SPB300/4			4	96	65	258	20	82	6	25
SPB300/5			5	104	75	258	22	101	6	25
SPB300/6			6	104	80	258	24	120	6	25



KEILRIEMENSCHLEIBEN MIT VOLLNABEN SPB

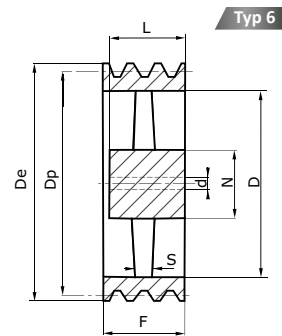
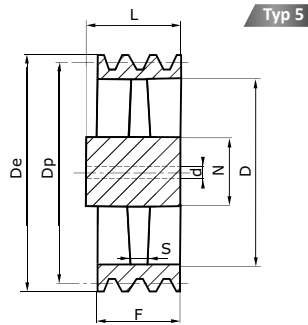

SPB										
Art. Nr.	Dp	De	Z	N	L	D	S	F	Typ	d
SPB315/1			1	76	50	273	15	25	5	20
SPB315/2			2	88	60	273	15	44	5	20
SPB315/3	315	322	3	90	60	273	18	63	6	20
SPB315/4			4	96	65	273	20	82	6	25
SPB315/5			5	104	75	273	22	101	6	25
SPB315/6			6	120	90	273	24	120	6	25
SPB355/1			1	80	50	313	15	25	5	20
SPB355/2			2	88	60	313	15	44	5	20
SPB355/3	355	362	3	90	60	313	18	63	6	25
SPB355/4			4	96	65	313	20	82	6	25
SPB355/5			5	104	75	313	22	101	6	25
SPB355/6			6	120	90	313	24	120	6	25
SPB400/1			1	85	55	358	18	25	5	20
SPB400/2			2	88	60	358	18	44	5	20
SPB400/3	400	407	3	96	65	358	22	63	5	25
SPB400/4			4	104	75	358	24	82	6	25
SPB400/5			5	112	85	358	26	101	6	25
SPB400/6			6	120	100	358	28	120	6	25
SPB425/3			3	96	65	383	22	63	5	20
SPB425/4	425	432	4	104	75	383	24	82	6	25
SPB425/5			5	112	85	383	26	101	6	25
SPB450/1			1	90	60	408	18	25	5	20
SPB450/2			2	90	60	408	18	44	5	20
SPB450/3	450	457	3	96	65	408	22	63	5	25
SPB450/4			4	104	75	408	24	82	6	25
SPB450/5			5	112	85	408	26	101	6	25
SPB450/6			6	120	100	408	28	120	6	25
SPB500/1			1	100	60	458	18	25	5	25
SPB500/2			2	100	65	458	20	44	5	25
SPB500/3	500	507	3	104	75	458	24	63	5	25
SPB500/4			4	112	85	458	28	82	5	25
SPB500/5			5	120	90	458	30	101	6	25
SPB500/6			6	128	105	458	33	120	6	25
SPB560/1			1	100	60	518	18	25	5	25
SPB560/2			2	100	65	518	20	44	5	25
SPB560/3	560	567	3	104	75	518	24	63	5	25
SPB560/4			4	112	85	518	28	82	5	25
SPB560/5			5	120	90	518	30	101	6	25
SPB560/6			6	128	105	518	33	120	6	25
SPB600/1			1	100	60	558	18	25	5	25
SPB600/2			2	100	65	558	20	44	5	25
SPB600/3	600	607	3	104	75	558	24	63	5	25
SPB600/4			4	115	85	558	28	82	5	25
SPB600/5			5	120	90	558	30	101	6	25
SPB600/6			6	129	105	558	33	120	6	25
SPB630/1			1	100	60	588	18	25	5	25
SPB630/2			2	100	65	588	20	44	5	25
SPB630/3	630	637	3	105	75	588	26	63	5	25
SPB630/4			4	120	85	588	28	82	5	25
SPB630/5			5	128	90	588	30	101	6	25
SPB630/6			6	140	105	588	33	120	6	25

Z = Anzahl der Rillen

KEILRIEMENSCHLEIBEN MIT VOLLNABEN SPC

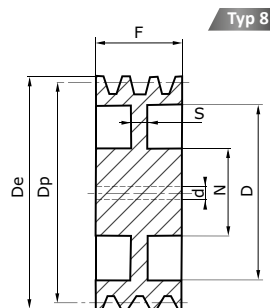
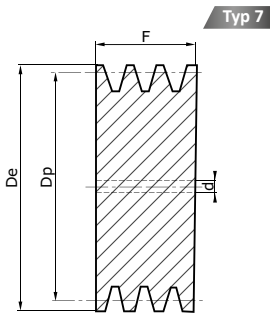
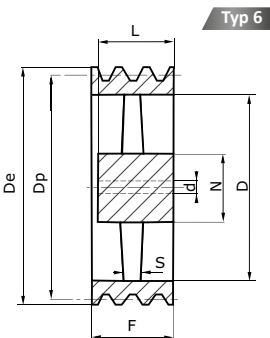
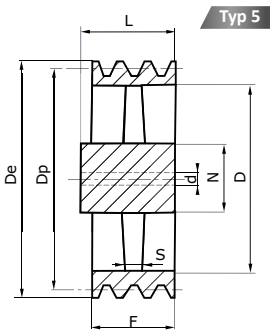
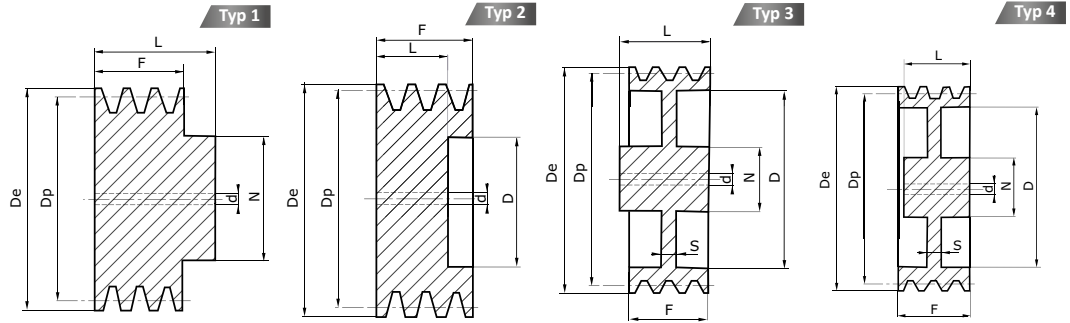
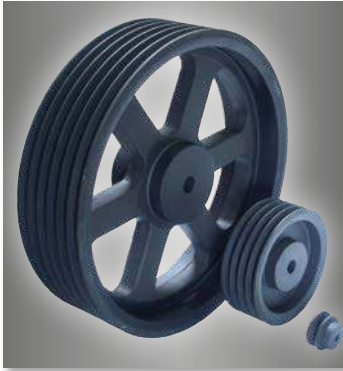

SPC										
Art. Nr.	Dp	De	Z	N	L	D	S	F	Typ	d
SPC100/1	100	109,6	1	60	50	-	-	34	1	15
SPC120/1	120	129,6	1	65	5	-	-	34	1	15
SPC120/2	2	-	-	-	-	-	-	59,5	7	15
SPC140/1	140	149,6	1	70	50	-	-	34	1	20
SPC140/2	2	-	-	-	-	-	-	59,5	7	20
SPC140/3	3	-	65	83	-	-	-	85	2	20
SPC140/4	4	-	80	83	-	-	-	110,5	2	20
SPC150/1	150	159,6	1	70	50	-	-	34	1	20
SPC150/2	2	-	-	-	-	-	-	59,5	7	20
SPC150/3	3	-	65	93	-	-	-	85	2	20
SPC150/4	4	-	80	93	-	-	-	110,5	2	20
SPC150/5	5	-	96	93	-	-	-	136	2	20
SPC160/1	160	169,6	1	72	50	103	-	34	1	20
SPC160/2	2	-	-	-	103	-	-	59,5	7	20
SPC160/3	3	-	65	103	-	-	-	85	2	20
SPC160/4	4	-	80	103	-	-	-	110,5	2	20
SPC160/5	5	-	96	103	-	-	-	136	2	20
SPC160/6	6	-	96	103	-	-	-	161,5	2	20
SPC180/1	180	189,6	1	76	50	123	16	34	3	20
SPC180/2	2	80	123	30	59,5	8	20			
SPC180/3	3	82	65	123	35	85	4	20		
SPC180/4	4	82	80	123	60	110,5	4	20		
SPC180/5	5	82	96	123	75	136	4	20		
SPC180/6	6	82	96	123	75	161,5	4	20		
SPC200/1	200	209,6	1	76	50	143	16	34	3	20
SPC200/2	2	80	60	143	20	59,5	3	20		
SPC200/3	3	86	65	143	25	85	4	20		
SPC200/4	4	90	90	143	70	110,5	4	20		
SPC200/5	5	90	100	143	80	136	4	25		
SPC200/6	6	90	100	143	80	161,5	4	25		
SPC225/1	225	234,6	1	86	50	168	16	34	3	20
SPC225/2	2	88	60	168	18	59,5	3	20		
SPC225/3	3	90	70	168	21	85	4	20		
SPC225/4	4	90	90	168	50	110,5	4	25		
SPC225/5	5	90	100	168	60	136	4	25		
SPC225/6	6	90	100	168	60	161,5	4	25		
SPC250/1	250	259,6	1	86	50	193	16	34	3	20
SPC250/2	2	92	60	193	18	59,5	3	20		
SPC250/3	3	92	70	193	21	85	4	20		
SPC250/4	4	100	90	193	30	110,5	4	25		
SPC250/5	5	102	100	193	50	136	4	25		
SPC250/6	6	102	100	193	50	161,5	4	25		
SPC280/1	280	289,6	1	86	50	223	16	34	3	20
SPC280/2	2	92	60	223	18	59,5	3	20		
SPC280/3	3	92	70	223	21	85	4	20		
SPC280/4	4	100	90	223	25	110,5	4	25		
SPC280/5	5	102	100	223	40	136	4	25		
SPC280/6	6	102	100	223	40	161,5	4	25		
SPC300/1	300	309,6	1	86	50	243	16	34	3	20
SPC300/2	2	92	60	243	18	59,5	3	20		
SPC300/3	3	92	70	243	21	85	4	20		
SPC300/4	4	100	90	243	25	110,5	4	25		
SPC300/5	5	104	100	243	25	136	4	25		
SPC300/6	6	104	100	243	25	161,5	4	25		

SPC										
Art. Nr.	Dp	De	Z	N	L	D	S	F	Typ	d
SPC315/1	315	324,6	1	92	50	258	16	34	5	20
SPC315/2	2	92	60	258	18	59,5	5	20		
SPC315/3	3	92	70	258	22	85	6	25		
SPC315/4	4	110	90	258	25	110,5	4	25		
SPC315/5	5	112	100	258	25	136	4	25		
SPC315/6	6	112	100	258	28	161,5	4	25		
SPC340/1	340	349,6	1	100	50	283	16	34	5	20
SPC340/2	2	100	60	283	18	59,5	5	20		
SPC340/3	3	100	70	283	22	85	6	25		
SPC340/4	4	114	90	283	25	110,5	6	25		
SPC340/5	5	114	100	283	28	136	6	25		
SPC340/6	6	114	100	283	30	161,5	6	25		
SPC355/1	355	364,6	1	110	50	298	16	34	5	20
SPC355/2	2	110	60	298	18	59,5	5	25		
SPC355/3	3	110	70	298	22	85	6	25		
SPC355/4	4	114	90	298	25	110,5	6	25		
SPC355/5	5	114	100	298	28	136	6	25		
SPC355/6	6	114	100	298	30	161,5	6	25		
SPC400/1	400	409,6	1	110	60	343	18	34	5	25
SPC400/2	2	110	70	343	20	59,5	5	25		
SPC400/3	3	114	90	343	24	85	5	25		
SPC400/4	4	114	90	343	26	110,5	6	25		
SPC400/5	5	120	100	343	28	136	6	25		
SPC400/6	6	120	100	343	30	161,5	6	25		
SPC450/1	450	459,6	1	110	60	393	18	34	5	25
SPC450/2	2	110	70	393	20	59,5	5	25		
SPC450/3	3	114	90	393	24	85	5	25		
SPC450/4	4	120	90	393	28	110,5	6	25		
SPC450/5	5	120	100	393	30	136	6	25		
SPC450/6	6	120	100	393	32	161,5	6	25		
SPC500/1	500	509,6	1	114	60	443	18	34	5	25
SPC500/2	2	114	70	443	20	59,5	5	25		
SPC500/3	3	114	90	443	24	85	5	25		
SPC500/4	4	126	90	443	28	110,5	6	25		
SPC500/5	5	126	100	443	30	136	6	25		
SPC500/6	6	126	100	443	32	161,5	6	25		
SPC560/1	560	569,6	1	114	60	503	20	34	5	25
SPC560/2	2	114	70	503	24	59,5	5	25		
SPC560/3	3	114	90	503	28	85	5	25		
SPC560/4	4	130	100	503	30	110,5	6	25		
SPC560/5	5	130	100	503	32	136	6	25		
SPC560/6	6	130	100	503	35	161,5	6	25		
SPC600/1	600	609,6	1	114	60	543	20	34	5	25
SPC600/2	2	114	70	543	24	59,5	5	25		
SPC600/3	3	114	90	543	28	85	5	25		
SPC600/4	4	130	90	543	30	110,5	6	25		
SPC600/5	5	130	100	543	32	136	6	25		
SPC600/6	6	130	100	543	35	161,5	6	25		
SPC630/1	630	639,6	1	114	60	573	20	34	5	25
SPC630/2	2	114	70	573	24	59,5	5	25		
SPC630/3	3	114	90	573	28	85	5	25		
SPC630/4	4	130	90	573	30	110,5	6	25		
SPC630/5	5	130	100	573	32	136	6	25		
SPC630/6	6	130	100	573	35	161,5	6	25		

Z = Anzahl der Rillen



KEILRIEMENSCHLEIBEN FÜR KLEMMBUCHSEN SPZ

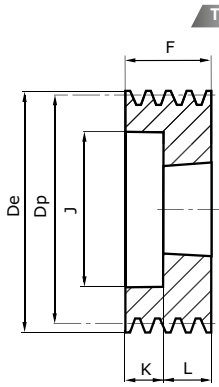
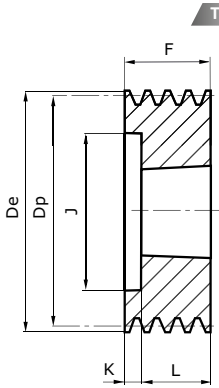
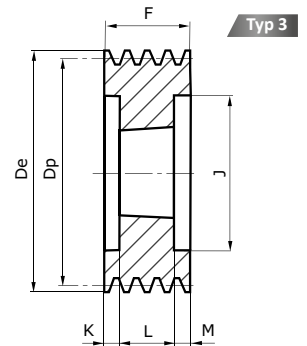
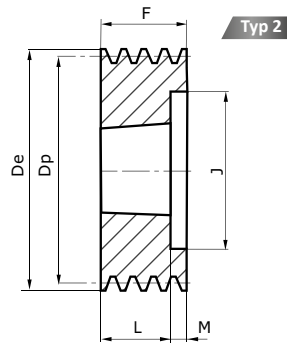
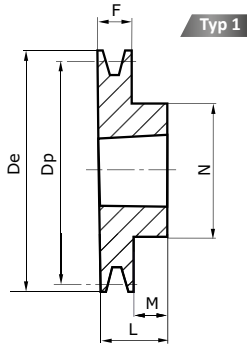

Typ 8

Typ 9

SPZ													
Art. Nr.	Dp	De	Z	Buchse	E	F	J	K	L	M	N	Typ	
SPZ050/1MA*	50	54	1	1008	-	37	26	12	25	-	-	9	
SPZ050/2MA*		2	1008	-	50	26	25	25	-	-	-	9	
SPZ056/1MA*	56	60	1	1008	-	37	32	12	25	-	-	9	
SPZ056/2MA*		2	1008	-	49	32	27	22	-	-	-	9	
SPZ060/1MA*	60	64	1	1008	-	22	-	22	6	-	-	1	
SPZ060/2MA*		2	1108	-	49	36	27	22	-	-	-	9	
SPZ063/1MA	63	67	1	1108	-	16	-	22	6	56	-	1	
SPZ063/2MA			2	1108	-	28	40	6	22	-	-	-	8
SPZ063/3MA			3	1108	-	40	40	-	22	-	-	-	8
SPZ067/1MA	67	71	1	1108	-	16	-	22	6	60	-	1	
SPZ067/2MA			2	1108	-	28	42	6	22	-	-	-	8
SPZ067/3MA			3	1108	-	40	42	18	22	-	-	-	8
SPZ071/1MA	71	75	1	1108	-	16	-	22	6	60	-	1	
SPZ071/2MA			2	1108	-	28	42	6	22	-	-	-	8
SPZ071/3MA			3	1108	-	40	42	18	22	-	-	-	8
SPZ075/1MA	75	79	1	1108	-	16	-	22	6	60	-	1	
SPZ075/2MA			2	1210	-	28	51	3	25	-	-	-	8
SPZ075/3MA			3	1210	-	40	51	15	25	-	-	-	8
SPZ080/1MA	80	84	1	1210	-	16	-	25	9	75	-	1	
SPZ080/2MA			2	1210	-	28	51	3	25	-	-	-	8
SPZ080/3MA			3	1210	-	40	51	15	25	-	-	-	8
SPZ080/4MA			4	1210	-	52	51	27	25	-	-	-	8
SPZ085/1MA	85	89	1	1210	-	16	-	25	9	80	-	1	
SPZ085/2MA			2	1610	-	28	60	3	25	-	-	-	8
SPZ085/3MA			3	1610	-	40	60	15	25	-	-	-	8
SPZ085/4MA			4	1610	-	52	60	27	25	-	-	-	8
SPZ085/5MA	90	94	5	1610	-	64	60	39	25	-	-	8	
SPZ090/1MA			1	1210	-	16	-	25	9	80	-	1	
SPZ090/2MA			2	1610	-	28	61	3	25	-	-	-	8
SPZ090/3MA			3	1610	-	40	61	15	25	-	-	-	8
SPZ090/4MA			4	1610	-	52	61	27	25	-	-	-	8
SPZ090/5MA			5	1610	-	64	61	39	25	-	-	-	8
SPZ090/6MA	6	1610	-	76	61	51	25	-	-	-	8		
SPZ095/1MA	95	99	1	1210	-	16	-	25	9	85	-	1	
SPZ095/2MA			2	1610	-	28	66	3	25	-	-	-	8
SPZ095/3MA			3	1610	-	40	66	15	25	-	-	-	8
SPZ095/4MA			4	1610	-	52	66	27	25	-	-	-	8
SPZ095/5MA			5	1610	-	64	66	39	25	-	-	-	8
SPZ095/6MA			6	1610	-	76	66	51	25	-	-	-	8
SPZ100/1MA	100	104	1	1210	-	16	-	25	9	85	-	1	
SPZ100/2MA			2	1610	-	28	71	3	25	-	-	-	8
SPZ100/3MA			3	1610	-	40	71	15	25	-	-	-	8
SPZ100/4MA			4	1610	-	52	71	27	25	-	-	-	8
SPZ100/5MA			5	2012	-	64	71	32	32	-	-	-	8
SPZ100/6MA			6	2012	-	76	71	44	32	-	-	-	8

SPZ													
Art. Nr.	Dp	De	Z	Buchse	E	F	J	K	L	M	N	Typ	
SPZ106/1MA	106	110	1	1610	-	16	-	25	9	92	-	1	
SPZ106/2MA			2	1610	-	28	76	3	25	-	-	-	8
SPZ106/3MA			3	1610	-	40	76	15	25	-	-	-	8
SPZ106/4MA			4	1610	-	52	76	27	25	-	-	-	8
SPZ106/5MA			5	2012	-	64	76	32	32	-	-	-	8
SPZ106/6MA			6	2012	-	76	76	44	32	-	-	-	8
SPZ112/1MA	112	116	1	1610	-	16	-	25	9	92	-	1	
SPZ112/2MA			2	1610	-	28	83	3	25	-	-	-	8
SPZ112/3MA			3	2012	-	40	83	8	32	-	-	-	8
SPZ112/4MA			4	2012	-	52	83	20	32	-	-	-	8
SPZ112/5MA			5	2012	-	64	83	32	32	-	-	-	8
SPZ112/6MA			6	2012	-	76	83	44	32	-	-	-	8
SPZ118/1MA	118	122	1	1610	-	16	-	25	9	92	-	1	
SPZ118/2MA			2	1610	-	28	90	3	25	-	-	-	8
SPZ118/3MA			3	2012	-	40	90	8	32	-	-	-	8
SPZ118/4MA			4	2012	-	52	90	20	32	-	-	-	8
SPZ118/5MA			5	2012	-	64	90	32	32	-	-	-	8
SPZ118/6MA			6	2517	-	76	90	31	45	-	-	-	8
SPZ125/1MA	125	129	1	1610	-	16	-	25	9	92	-	1	
SPZ125/2MA			2	1610	-	28	96	3	25	-	-	-	8
SPZ125/3MA			3	2012	-	40	96	-	32	8	-	-	2
SPZ125/4MA			4	2012	-	52	96	-	32	20	-	-	2
SPZ125/5MA			5	2012	-	64	96	32	32	-	-	-	8
SPZ125/6MA			6	2517	-	76	96	31	45	-	-	-	8
SPZ132/1MA	132	136	1	1610	-	16	-	25	9	92	-	1	
SPZ132/2MA			2	1610	-	28	103	3	25	-	-	-	8
SPZ132/3MA			3	2012	-	40	103	-	32	8	-	-	2
SPZ132/4MA			4	2012	-	52	103	-	32	20	-	-	2
SPZ132/5MA			5	2517	-	64	103	19	45	19	-	-	8
SPZ132/6MA			6	2517	-	76	103	31	45	-	-	-	8
SPZ140/1MA	140	144	1	1610	-	16	-	25	9	92	-	1	
SPZ140/2MA			2	1610	-	28	111	3	25	-	-	-	8
SPZ140/3MA			3	2012	-	40	111	-	32	8	-	-	2
SPZ140/4MA			4	2012	-	52	111	-	32	20	-	-	2
SPZ140/5MA			5	2517	-	64	111	-	45	19	-	-	2
SPZ140/6MA			6	2517	-	76	111	-	45	31	-	-	2
SPZ140/8MA			8	2517	-	100	111	27.5	45	27.5	-	-	3
SPZ150/1MA			150	154	1	1610	-	16	-	25	9	92	-
SPZ150/2MA	2	2012			-	28	-	-	32	4	112	-	1
SPZ150/3MA	3	2012			-	40	121	-	32	8	-	-	2
SPZ150/4MA	4	2517			-	52	121	-	45	7	-	-	2
SPZ150/5MA	5	2517			-	64	121	-	45	19	-	-	2
SPZ150/6MA	6	2517			-	76	121	-	45	31	-	-	2
SPZ150/8MA	8	2517			-	100	121	27.5	45	27.5	-	-	3

Z = Anzahl der Rillen
* Ausführung in Stahl

KEILRIEMENSCHLEIBEN FÜR KLEMMBUCHSEN SPZ

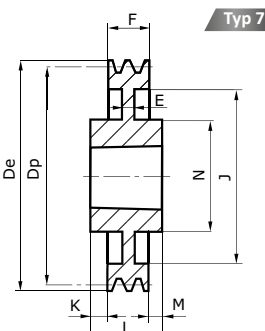
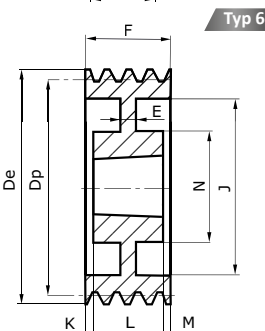
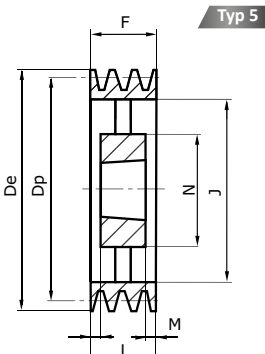
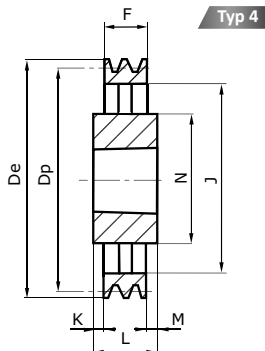
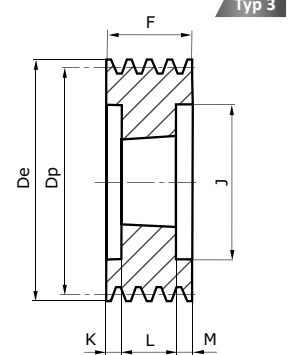
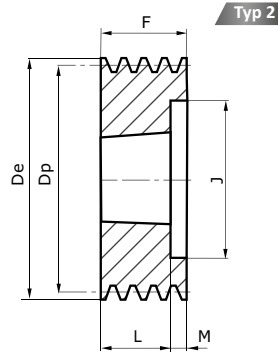
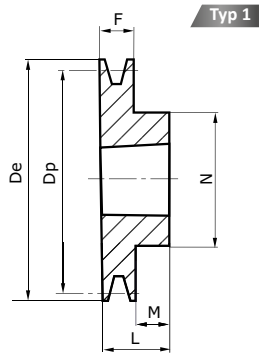

SPZ												
Art. Nr.	Dp	De	Z	Buchse	E	F	J	K	L	M	N	Typ
SPZ160/1MA	1	1610	-	16	-	-	25	9	92	1		
SPZ160/2MA	2	2012	-	28	-	-	32	4	112	1		
SPZ160/3MA	3	2012	-	40	131	-	32	8	-	2		
SPZ160/4MA	160	164	4	2517	-	52	131	-	45	7	-	2
SPZ160/5MA	5	2517	-	64	131	-	45	19	-	2		
SPZ160/6MA	6	2517	-	76	131	-	45	31	-	2		
SPZ160/8MA	8	2517	-	100	131	27,5	45	27,5	-	3		
SPZ170/1MA	1	1610	-	16	-	-	25	9	92	1		
SPZ170/2MA	2	2012	-	28	-	-	32	4	112	1		
SPZ170/3MA	3	2012	-	40	141	4	32	4	-	3		
SPZ170/4MA	170	174	4	2517	-	52	141	-	45	7	-	2
SPZ170/5MA	5	2517	-	64	141	-	45	19	-	2		
SPZ170/6MA	6	2517	-	76	141	-	45	31	-	2		
SPZ180/1MA	1	1610	6	16	152	-	25	9	92	7		
SPZ180/2MA	2	2012	6	28	152	-	32	4	112	7		
SPZ180/3MA	3	2012	7	40	151	-	32	8	106	6		
SPZ180/4MA	180	184	4	2517	-	52	151	-	45	7	-	2
SPZ180/5MA	5	2517	-	64	151	-	45	19	-	2		
SPZ180/6MA	6	2517	-	76	151	15,5	45	15,5	-	3		
SPZ180/8MA	8	2517	-	100	151	27,5	45	27,5	-	3		
SPZ190/1MA	1	1610	12	16	162	-	25	9	92	7		
SPZ190/2MA	2	2012	12	28	162	-	32	4	112	7		
SPZ190/3MA	3	2012	10	40	161	4	32	4	112	6		
SPZ190/4MA	190	194	4	2517	-	52	161	3,5	45	3,5	-	3
SPZ190/5MA	5	2517	-	64	161	9,5	45	9,5	-	3		
SPZ190/6MA	6	2517	-	76	161	15,5	45	15,5	124	3		
SPZ200/1MA	1	2012	10	16	171	-	32	16	112	7		
SPZ200/2MA	2	2012	6	28	171	-	32	4	112	7		
SPZ200/3MA	3	2012	10	40	171	4	32	4	112	6		
SPZ200/4MA	200	204	4	2517	8	52	171	3,5	45	3,5	124	6
SPZ200/5MA	5	2517	-	64	171	9,5	45	9,5	-	3		
SPZ200/6MA	6	2517	-	76	171	15,5	45	15,5	124	3		
SPZ200/8MA	8	3020	-	100	171	24,5	51	24,5	-	3		
SPZ224/1MA	1	2012	15	16	195	-	32	16	112	7		
SPZ224/2MA	2	2012	15	28	195	-	32	4	112	4		
SPZ224/3MA	3	2012	12	40	195	4	32	4	112	6		
SPZ224/4MA	224	228	4	2517	14	52	195	3,5	45	3,5	124	6
SPZ224/5MA	5	2517	20	64	195	9,5	45	9,5	124	6		
SPZ224/6MA	6	2517	26	76	195	15,5	45	15,5	124	6		
SPZ224/8MA	8	3020	-	100	195	24,5	51	24,5	-	8		
SPZ250/1MA	1	2012	-	16	221	8	32	8	112	4		
SPZ250/2MA	2	2012	-	28	221	2	32	2	112	4		
SPZ250/3MA	3	2012	-	40	221	4	32	4	112	5		
SPZ250/4MA	250	254	4	2517	12	52	221	3,5	45	3,5	124	6
SPZ250/5MA	5	2517	-	16	64	221	9,5	45	9,5	124	6	
SPZ250/6MA	6	2517	-	26	76	221	15,5	45	15,5	124	6	
SPZ250/8MA	8	3020	-	100	221	24,5	51	24,5	146	6		

SPZ												
Art. Nr.	Dp	De	Z	Buchse	E	F	J	K	L	M	N	Typ
SPZ280/1MA	1	2012	-	16	251	8	32	8	112	4		
SPZ280/2MA	2	2012	-	28	251	2	32	2	112	4		
SPZ280/3MA	3	2517	-	40	251	2,5	45	2,5	124	4		
SPZ280/4MA	280	284	4	2517	14	52	251	3,5	45	3,5	124	6
SPZ280/5MA	5	2517	15	64	251	9,5	45	9,5	124	6		
SPZ280/6MA	6	2517	15	76	251	15,5	45	15,5	124	6		
SPZ280/8MA	8	3020	-	100	251	24,5	51	24,5	146	6		
SPZ315/1MA	1	2012	-	16	286	8	32	8	112	4		
SPZ315/2MA	2	2012	-	28	286	2	32	2	112	4		
SPZ315/3MA	3	2517	-	40	286	2,5	45	2,5	124	4		
SPZ315/4MA	315	319	4	2517	-	52	286	3,5	45	3,5	124	5
SPZ315/5MA	5	2517	-	64	286	9,5	45	9,5	124	5		
SPZ315/6MA	6	2517	15	76	286	15,5	45	15,5	124	6		
SPZ355/1MA	1	2012	-	16	326	8	32	8	112	4		
SPZ355/2MA	2	2012	-	28	326	2	32	2	112	4		
SPZ355/3MA	3	2517	-	40	326	2,5	45	2,5	124	4		
SPZ355/4MA	355	359	4	2517	-	52	326	3,5	45	3,5	124	5
SPZ355/5MA	5	2517	-	64	326	9,5	45	9,5	124	5		
SPZ355/6MA	6	2517	-	76	326	15,5	45	15,5	124	5		
SPZ355/8MA	8	3030	-	100	326	12	76	12	146	5		
SPZ400/1MA	1	2012	-	16	371	8	32	8	112	4		
SPZ400/2MA	2	2517	-	28	371	8,5	45	8,5	124	4		
SPZ400/3MA	3	2517	-	40	371	2,5	45	2,5	124	4		
SPZ400/3MA	400	404	4	2517	-	52	371	3,5	45	3,5	124	5
SPZ400/5MA	5	3020	-	64	371	6,5	51	6,5	146	5		
SPZ400/6MA	6	3030	-	76	371	-	76	-	146	5		
SPZ400/8MA	8	3030	-	100	371	12	76	12	146	5		
SPZ450/1MA	1	2517	-	16	421	14,5	45	14,5	124	4		
SPZ450/2MA	2	2517	-	28	421	8,5	45	8,5	124	4		
SPZ450/3MA	3	2517	-	40	421	2,5	45	2,5	124	4		
SPZ450/4MA	450	454	4	3020	-	52	421	0,5	51	0,5	146	5
SPZ450/5MA	5	3020	-	64	421	6,5	51	6,5	146	5		
SPZ450/6MA	6	3030	-	76	421	-	76	-	146	5		
SPZ450/8MA	8	3535	-	100	421	5,5	89	5,5	173	5		
SPZ500/3MA	3	2517	-	40	471	2,5	45	2,5	124	4		
SPZ500/4MA	500	504	4	3020	-	52	471	0,5	51	0,5	146	5
SPZ500/5MA	5	3030	-	64	471	6	76	6	146	4		
SPZ500/6MA	6	3030	-	76	471	-	76	-	146	5		
SPZ630/3MA	3	3020	-	40	601	5,5	51	2,5	150	4		
SPZ630/4MA	630	634	4	3030	-	52	601	12	76	12	146	4
SPZ630/5MA	5	3030	-	64	601	6	76	6	146	4		
SPZ630/6MA	6	3535	-	76	601	6,5	89	6,5	175	4		
SPZ800/3MA	3	3020	-	40	771	5,5	51	2,5	146	4		
SPZ800/4MA	4	3030	-	52	771	12	76	12	146	4		
SPZ800/5MA	800	804	5	3535	-	64	771	12,5	89	12,5	178	4
SPZ800/6MA	6	3535	-	76	771	6,5	89	6,5	178	4		

Z = Anzahl der Rillen
* Ausführung in Stahl



KEILRIEMENSCHWEIBEN FÜR KLEMMBUCHSEN SPA

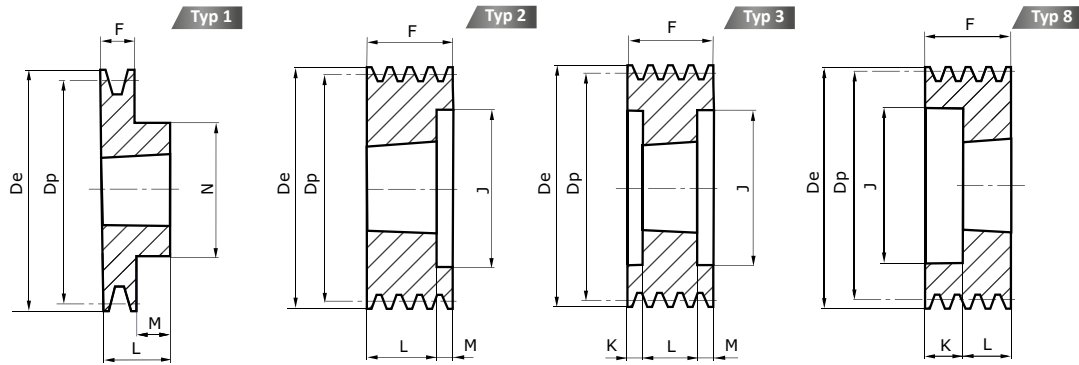

SPA													
Art. Nr.	Dp	De	Z	Buchse	E	F	J	K	L	M	N	Typ	
SPA063/1MA	63	68.5	1	1008	-	20	-	-	22	2	56	1	
SPA063/2MA*			2	1008	-	35	38	13	22	-	-	-	8
SPA067/1MA	67	72.5	1	1108	-	20	-	-	22	2	56	1	
SPA067/2MA			2	1108	-	35	38	13	22	-	-	-	8
SPA071/1MA	71	76.5	1	1108	-	20	-	-	22	2	60	1	
SPA071/2MA			2	1108	-	35	40	13	22	-	-	-	8
SPA071/3MA			3	1108	-	50	40	28	22	-	-	-	8
SPA075/1MA	75	80.5	1	1108	-	20	-	-	22	2	56	1	
SPA075/2MA			2	1108	-	35	44	13	25	-	-	-	8
SPA075/3MA			3	1108	-	50	44	28	22	-	-	-	8
SPA080/1MA	80	85.5	1	1210	-	20	-	-	25	5	75	1	
SPA080/2MA			2	1210	-	35	50	10	25	-	-	-	8
SPA080/3MA			3	1210	-	50	50	25	25	-	-	-	8
SPA085/1MA	85	90.5	1	1210	-	20	-	-	25	5	80	1	
SPA085/2MA			2	1210	-	35	50	10	25	-	-	-	8
SPA085/3MA			3	1210	-	50	55	25	25	-	-	-	8
SPA090/1MA	90	95.5	1	1210	-	20	-	-	25	5	80	1	
SPA090/2MA			2	1610	-	35	59	10	25	-	-	-	8
SPA090/3MA			3	1610	-	50	59	25	25	-	-	-	8
SPA090/4MA			4	1615	-	65	59	27	38	-	-	-	8
SPA095/1MA	95	100.5	1	1210	-	20	-	-	25	5	85	1	
SPA095/2MA			2	1610	-	35	63	10	25	-	-	-	8
SPA095/3MA			3	1610	-	50	63	25	25	-	-	-	8
SPA095/4MA			4	1615	-	65	63	27	38	-	-	-	8
SPA100/1MA	100	105.5	1	1610	-	20	-	-	25	5	85	1	
SPA100/2MA			2	1610	-	35	66	10	25	-	-	-	8
SPA100/3MA			3	1610	-	50	66	-	25	25	-	-	2
SPA100/4MA			4	1615	-	65	66	-	38	27	-	-	2
SPA100/5MA			5	1615	-	80	66	-	38	42	-	-	2
SPA100/6MA			6	1610	-	95	66	30	25	40	-	-	3
SPA106/1MA	106	111.5	1	1610	-	20	-	-	25	5	92	1	
SPA106/2MA			2	1610	-	35	72	10	25	-	-	-	8
SPA106/3MA			3	1610	-	50	72	-	25	25	-	-	2
SPA106/4MA			4	2012	-	65	72	33	32	-	-	-	8
SPA106/5MA			5	2012	-	80	72	48	32	-	-	-	8
SPA106/6MA			6	2012	-	95	72	63	32	-	-	-	8
SPA112/1MA	112	117.5	1	1610	-	20	-	-	25	5	92	1	
SPA112/2MA			2	1610	-	35	78	10	25	-	-	-	8
SPA112/3MA			3	2012	-	50	78	18	32	-	-	-	8
SPA112/4MA			4	2012	-	65	78	33	32	-	-	-	8
SPA112/5MA			5	2012	-	80	78	48	32	-	-	-	8
SPA112/6MA			6	2012	-	95	78	63	32	-	-	-	8

SPA													
Art. Nr.	Dp	De	Z	Buchse	E	F	J	K	L	M	N	Typ	
SPA118/1MA	118	123.5	1	1610	-	20	-	-	25	5	92	1	
SPA118/2MA			2	1610	-	35	84	10	25	-	-	-	8
SPA118/3MA			3	2012	-	50	84	-	32	18	-	-	2
SPA118/4MA			4	2012	-	65	84	-	32	33	-	-	2
SPA118/5MA	118	123.5	5	2012	-	80	84	-	32	48	-	2	
SPA118/6MA			6	2012	-	95	84	63	32	-	-	-	8
SPA125/1MA	125	130.5	1	1610	-	20	-	-	25	5	92	1	
SPA125/2MA			2	1610	-	35	91	10	25	-	-	-	8
SPA125/3MA			3	2012	-	50	91	-	32	18	-	-	2
SPA125/4MA			4	2012	-	65	91	-	32	33	-	-	2
SPA125/5MA	125	130.5	5	2012	-	80	91	24	32	24	-	3	
SPA125/6MA			6	2012	-	95	91	31.5	32	31.5	-	-	3
SPA132/1MA	132	137.5	1	1610	-	20	-	-	25	5	92	1	
SPA132/2MA			2	2012	-	35	98	3	32	-	-	-	8
SPA132/3MA			3	2012	-	50	98	-	32	18	-	-	2
SPA132/4MA			4	2517	-	65	98	-	45	20	-	-	2
SPA132/5MA	132	137.5	5	2517	-	80	98	17.5	45	17.5	-	3	
SPA132/6MA			6	2517	-	95	98	25	45	25	-	-	3
SPA140/1MA	140	145.5	1	1610	-	20	-	-	25	5	92	1	
SPA140/2MA			2	2012	-	35	106	3	32	-	-	-	8
SPA140/3MA			3	2517	-	50	106	5	45	-	-	-	8
SPA140/4MA			4	2517	-	65	106	-	45	20	-	-	2
SPA140/5MA			5	2517	-	80	106	17.5	45	17.5	-	-	3
SPA140/6MA			6	2517	-	95	106	25	45	25	-	-	3
SPA150/1MA	150	155.5	1	1610	-	20	-	-	25	5	92	1	
SPA150/2MA			2	2012	-	35	116	3	32	-	-	-	8
SPA150/3MA			3	2517	-	50	116	5	45	-	-	-	8
SPA150/4MA			4	2517	-	65	116	-	45	20	-	-	2
SPA150/5MA			5	2517	-	80	116	17.5	45	17.5	-	-	3
SPA150/6MA			6	2517	-	95	116	25	45	25	-	-	3
SPA160/1MA	160	165.5	1	1610	-	20	-	-	25	5	92	1	
SPA160/2MA			2	2012	-	35	125	3	32	-	-	-	8
SPA160/3MA			3	2517	-	50	125	5	45	-	-	-	8
SPA160/4MA			4	2517	-	65	125	-	45	20	-	-	2
SPA160/5MA			5	2517	-	80	125	17.5	45	17.5	-	-	3
SPA160/6MA			6	2517	-	95	125	25	45	25	-	-	3
SPA170/1MA	170	175.5	1	1610	-	20	-	-	25	5	92	1	
SPA170/2MA			2	2012	-	35	135	3	32	-	-	-	8
SPA170/3MA			3	2517	-	50	135	5	45	-	-	-	8
SPA170/4MA			4	2517	-	65	135	-	45	20	-	-	2
SPA170/5MA			5	2517	-	80	135	17.5	45	17.5	-	-	3

Z = Anzahl der Rillen
* Ausführung in Stahl

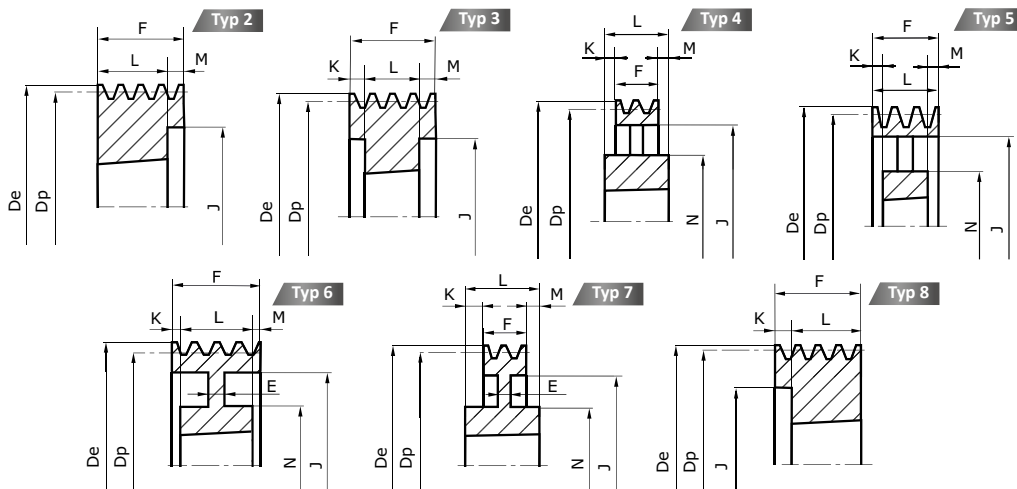
KEILRIEMENSCHLEIBEN FÜR KLEMMBUCHSEN SPA

SPA												SPA													
Art. Nr.	Dp	De	Z	Buchse	E	F	J	K	L	M	N	Typ	Art. Nr.	Dp	De	Z	Buchse	E	F	J	K	L	M	N	Typ
SPA180/1MA		1	1610	6	20	146	-	25	5	92	7	SPA355/1MA		1	2012	-	20	320	-	32	12	112	4		
SPA180/2MA		2	2012	10	35	146	1,5	32	1,5	108	6	SPA355/2MA		2	2517	-	35	320	-	45	10	124	4		
SPA180/3MA	180	185,5	3	2517	-	50	146	5	45	-	-	8	SPA355/3MA	355	360,5	3	3020	-	50	320	0,5	51	0,5	159	4
SPA180/4MA			4	2517	-	65	146	-	45	20	-	2	SPA355/4MA			4	3020	-	65	320	7	51	7	159	5
SPA180/5MA			5	3020	-	80	146	-	51	29	-	3	SPA355/5MA			5	3535	-	80	320	4,5	89	4,5	175	4
SPA180/6MA		6	3020	-	95	146	22	51	22	-	3	SPA355/6MA		6	3535	-	95	320	3	89	3	175	5		
SPA190/1MA		1	1610	6	20	156	-	25	5	92	7	SPA400/1MA		1	2012	-	20	365	-	32	12	112	4		
SPA190/2MA		2	2012	6	35	156	1,5	32	3	108	6	SPA400/2MA		2	2517	-	35	365	-	45	10	124	4		
SPA190/3MA	190	195,5	3	2517	-	50	156	5	45	-	-	8	SPA400/3MA	400	405,5	3	3020	-	50	365	-	51	1	159	4
SPA190/4MA			4	2517	-	65	156	-	45	20	-	2	SPA400/4MA			4	3020	-	65	365	7	51	7	159	5
SPA190/5MA			5	3020	-	80	156	14,5	51	14,5	-	2	SPA400/5MA			5	3535	-	80	365	4,5	89	4,5	175	4
SPA200/1MA		1	2012	6	20	165	-	32	12	108	7	SPA400/6MA		6	3535	-	95	365	3	89	3	175	5		
SPA200/2MA		2	2517	10	35	165	5	45	5	123	7	SPA450/1MA		1	2012	-	20	415	-	32	12	112	4		
SPA200/3MA	200	205,5	3	2517	20	50	165	2,5	45	2,5	123	6	SPA450/2MA		2	2517	-	35	465	-	45	10	124	4	
SPA200/4MA			4	3020	-	65	165	-	51	14	-	2	SPA450/3MA	450	455,5	3	3020	-	50	415	-	51	1	159	4
SPA200/5MA			5	3020	-	80	165	14,5	51	14,5	-	3	SPA450/4MA			4	3020	-	65	415	7	51	7	159	5
SPA200/6MA	6	3020	-	95	165	22	51	22	-	3	SPA450/5MA	5	3535			-	80	415	4,5	89	4,5	175	4		
SPA212/1MA		1	2012	10	20	177	-	32	12	110	7	SPA450/6MA		6	3535	-	95	415	3	89	3	175	5		
SPA212/2MA		2	2517	18	35	177	5	45	5	123	7	SPA500/1MA		1	2517	-	20	465	-	45	25	124	4		
SPA212/3MA	212	217,5	3	2517	20	50	177	2,5	45	2,5	123	6	SPA500/2MA		2	2517	-	35	525	-	45	10	125	4	
SPA212/4MA			4	3020	-	65	177	-	51	14	-	2	SPA500/3MA	500	505,5	3	3020	-	50	465	-	51	1	159	4
SPA212/5MA			5	3020	-	80	177	-	51	29	-	2	SPA500/4MA			4	3020	-	65	465	7	51	7	159	5
SPA224/1MA		1	2012	10	20	189	-	32	12	112	7	SPA500/5MA				5	3535	-	80	465	4,5	89	4,5	175	4
SPA224/2MA		2	2517	18	35	189	-	45	10	124	7	SPA500/6MA		6	3535	-	95	465	3	89	3	175	5		
SPA224/3MA	224	229,5	3	2517	20	50	189	2,5	45	2,5	124	6	SPA560/3MA		3	3020	-	50	525	-	51	1	150	4	
SPA224/4MA			4	3020	-	65	189	-	51	14	-	2	SPA560/4MA	560	565,5	4	3535	-	65	525	12	89	12	175	4
SPA224/5MA			5	3020	-	80	189	-	51	29	-	2	SPA560/5MA			5	3535	-	80	525	4,5	89	4,5	175	4
SPA224/6MA	6	3020	-	95	189	22	51	22	-	3	SPA560/6MA	6	3535			-	95	525	3	89	3	175	5		
SPA250/1MA		1	2012	10	20	215	6	32	6	112	7	SPA630/1MA		1	2517	-	20	595	-	45	25	124	4		
SPA250/2MA		2	2517	12	35	215	5	45	5	124	7	SPA630/2MA		2	3020	-	35	595	8	51	18	159	4		
SPA250/3MA	250	255,5	3	2517	20	50	215	2,5	45	2,5	124	6	SPA630/3MA	630	635,5	3	3020	-	50	595	-	51	1	150	4
SPA250/4MA			4	3020	20	65	215	7	51	7	159	6	SPA630/4MA			4	3535	-	65	595	12	89	12	175	4
SPA250/5MA			5	3020	20	80	215	14,5	51	14,5	159	6	SPA630/5MA			5	3535	-	80	595	4,5	89	4,5	175	4
SPA250/6MA		6	3020	20	95	215	22	51	22	155	6	SPA630/6MA		6	4040	-	95	595	3,5	102	3,5	210	4		
SPA280/1MA		1	2012	10	20	245	-	32	12	112	7	SPA800/3MA		3	3535	-	50	765	19,05	89	19,5	175	4		
SPA280/2MA		2	2517	12	35	245	-	45	10	124	7	SPA800/4MA		4	3535	-	65	765	12	89	12	175	4		
SPA280/3MA	280	285,5	3	2517	20	50	245	2,5	45	2,5	124	6	SPA800/5MA	800	805,5	5	4040	-	80	765	11	102	11	210	4
SPA280/4MA			4	3020	25	65	245	7	51	7	159	6	SPA800/6MA			6	4040	-	95	765	3,5	102	3,5	210	4
SPA280/5MA			5	3535	25	80	245	4,5	89	4,5	175	7	SPA1000/3MA				3	3535	-	50	965	19,05	89	19,5	175
SPA280/6MA		6	3535	25	95	245	3	89	3	175	6	SPA1000/4MA		4	4040	-	65	965	18,5	102	18,5	210	4		
SPA315/1MA		1	2012	12	20	280	-	32	12	112	7	SPA1000/5MA		5	4545	-	80	965	17	114	17	242	4		
SPA315/2MA		2	2517	12	35	280	-	45	10	124	7	SPA1000/6MA		6	4545	-	95	965	9,5	114	9,5	242	4		
SPA315/3MA	315	320,5	3	3020	25	50	280	0,5	51	0,5	159	4													
SPA315/4MA			4	3020	25	65	280	7	51	7	159	6													
SPA315/5MA			5	3535	25	80	280	4,5	89	4,5	175	7													
SPA315/6MA		6	3535	25	95	280	3	89	3	175	6														

Z = Anzahl der Rillen



KEILRIEMENSCHLEIBEN FÜR KLEMMBUCHSEN SPB

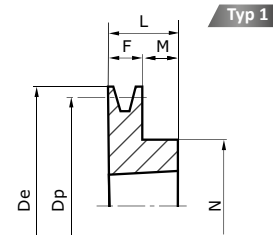

Typ 2

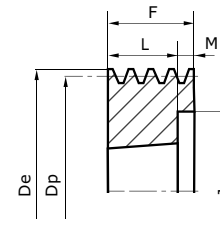

Typ 3

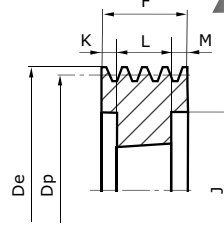

Typ 6

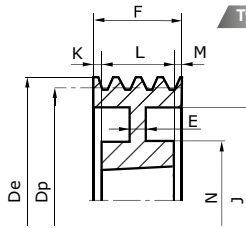

Typ 7

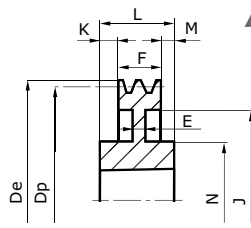

Typ 8

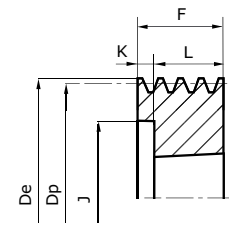

SPB													
Art. Nr.	Dp	De	Z	Buchse	E	F	J	K	L	M	N	Typ	
SPB100/1MA	100	107	1	1610	-	25	-	-	25	-	-	1	
SPB100/2MA			2	1610	-	44	62	19	25	-	-	-	8
SPB100/3MA			3	1610	-	63	62	38	25	-	-	-	8
SPB106/1MA	106	113	1	1610	-	25	-	-	25	-	-	1	
SPB106/2MA			2	1610	-	44	67	19	25	-	-	-	8
SPB106/3MA			3	1610	-	63	67	38	25	-	-	-	8
SPB112/1MA	112	119	1	1610	-	25	-	-	25	-	-	1	
SPB112/2MA			2	1610	-	44	72	19	25	-	-	-	8
SPB112/3MA			3	1610	-	63	72	38	25	-	-	-	8
SPB118/1MA	118	125	1	1610	-	25	-	-	25	-	-	1	
SPB118/2MA			2	1610	-	44	78	-	25	19	-	-	2
SPB118/3MA			3	1610	-	63	78	-	25	38	-	-	2
SPB125/1MA	125	132	1	1610	-	25	-	-	25	-	-	1	
SPB125/2MA			2	2012	-	44	82	-	32	12	-	-	2
SPB125/3MA			3	2012	-	63	82	-	32	31	-	-	2
SPB125/4MA	4	2012	-	82	82	25	32	25	-	-	3		
SPB125/5MA	5	2012	-	101	87	69	32	-	-	-	8		
SPB132/1MA	132	139	1	1610	-	25	-	-	25	-	-	1	
SPB132/2MA			2	2012	-	44	89	-	32	12	-	-	2
SPB132/3MA			3	2012	-	63	89	-	32	31	-	-	2
SPB132/4MA	4	2012	-	82	89	25	32	25	-	-	3		
SPB132/5MA	5	2517	-	101	94	56	45	-	-	-	8		
SPB140/1MA	140	147	1	1610	-	25	-	-	25	-	-	1	
SPB140/2MA			2	2012	-	44	97	-	32	12	-	-	2
SPB140/3MA			3	2012	-	63	97	-	32	31	-	-	2
SPB140/4MA	4	2517	-	82	100	18,5	45	18,5	-	-	3		
SPB140/5MA	5	2517	-	101	97	28	45	28	-	-	3		
SPB140/6MA	6	2517	-	120	100	37,5	45	37,5	-	-	3		
SPB140/8MA	8	2517	-	158	97	56,5	45	56,5	-	-	3		
SPB150/1MA	150	157	1	1610	-	25	-	-	25	-	-	1	
SPB150/2MA			2	2012	-	44	107	-	32	12	-	-	2
SPB150/3MA			3	2517	-	63	107	-	45	18	-	-	2
SPB150/4MA	4	2517	-	82	107	18,5	45	18,5	-	-	3		
SPB150/5MA	5	2517	-	101	107	28	45	28	-	-	3		
SPB150/6MA	6	2517	-	120	107	37,5	45	37,5	-	-	3		
SPB160/1MA	160	167	1	1610	-	25	-	-	25	-	-	1	
SPB160/2MA			2	2012	-	44	117	-	32	12	-	-	2
SPB160/3MA			3	2517	-	63	117	-	45	18	-	-	2
SPB160/4MA	4	2517	-	82	117	18,5	45	18,5	-	-	3		
SPB160/5MA	5	2517	-	101	117	28	45	28	-	-	3		
SPB160/6MA	6	3020	-	120	117	34,5	51	34,5	-	-	3		
SPB160/8MA	8	3020	-	158	117	53,5	51	53,5	-	-	3		
SPB170/1MA	170	177	1	1610	-	25	-	-	25	-	-	1	
SPB170/2MA			2	2012	-	44	127	-	32	12	-	-	2
SPB170/3MA			3	2517	-	63	127	-	45	18	-	-	2
SPB170/4MA	4	2517	-	82	127	18,5	45	18,5	-	-	3		
SPB170/5MA	5	3020	-	101	127	25	51	25	-	-	3		
SPB170/6MA	6	3020	-	120	127	34,5	51	34,5	-	-	3		
SPB170/8MA	8	3030	-	158	127	41	76	41	-	-	3		

Z = Anzahl der Rillen

SPB												
Art. Nr.	Dp	De	Z	Buchse	E	F	J	K	L	M	N	Typ
SPB180/1MA	180	187	1	1610	15	25	132	-	25	-	90	6
SPB180/2MA			2	2517	-	44	-	-	45	1	120	1
SPB180/3MA			3	2517	-	63	137	-	45	18	-	-
SPB180/4MA	4	2517	-	82	137	18,5	45	18,5	-	-	3	
SPB180/5MA	5	3020	-	101	137	25	51	25	-	-	3	
SPB180/6MA	6	3020	-	120	137	34,5	51	34,5	-	-	3	
SPB180/8MA	8	3030	-	158	137	41	76	41	-	-	3	
SPB190/1MA	190	197	1	2012	15	25	147	3,5	32	3,5	104	7
SPB190/2MA			2	2517	-	44	-	-	45	1	120	1
SPB190/3MA			3	2517	-	63	147	-	45	18	-	-
SPB190/4MA	4	2517	-	82	147	18,5	45	18,5	-	-	3	
SPB190/5MA	5	3020	-	101	147	25	51	25	-	-	3	
SPB190/6MA	6	3020	-	120	147	34,5	51	34,5	-	-	3	
SPB190/8MA	8	3030	-	158	147	41	76	41	-	-	3	
SPB200/1MA	200	207	1	2012	15	25	157	3,5	32	3,5	104	7
SPB200/2MA			2	2517	-	44	-	-	45	1	117	1
SPB200/3MA			3	2517	-	63	157	-	45	18	-	-
SPB200/4MA	4	3020	-	82	157	15,5	51	15,5	-	-	3	
SPB200/5MA	5	3020	-	101	157	25	51	25	-	-	3	
SPB200/6MA	6	3020	-	120	157	34,5	51	34,5	-	-	3	
SPB200/8MA	8	3535	-	158	157	34,5	89	34,5	-	-	3	
SPB212/1MA	212	219	1	2012	15	25	169	3,5	32	3,5	104	7
SPB212/2MA			2	2517	20	44	169	-	45	1	117	7
SPB212/3MA			3	2517	15	63	169	-	45	18	117	6
SPB212/4MA	4	3020	-	82	169	15,5	51	15,5	-	-	3	
SPB212/5MA	5	3020	-	101	169	25	51	25	-	-	3	
SPB212/6MA	6	3535	-	120	169	15,5	89	15,5	-	-	3	
SPB212/8MA	8	3535	-	158	169	34,5	89	34,5	-	-	3	
SPB224/1MA	224	231	1	2012	15	25	181	3,5	32	3,5	104	7
SPB224/2MA			2	2517	15	44	181	-	45	1	117	7
SPB224/3MA			3	2517	15	63	181	-	45	18	117	6
SPB224/4MA	4	3020	-	82	181	15,5	51	15,5	-	-	3	
SPB224/5MA	5	3020	-	101	181	25	51	25	-	-	3	
SPB224/6MA	6	3535	-	120	181	15,5	89	15,5	-	-	3	
SPB224/8MA	8	3535	-	158	181	34,5	89	34,5	-	-	3	
SPB224/10MA	10	3535	-	196	181	53,5	89	53,3	-	-	3	
SPB236/1MA	236	243	1	2012	15	25	193	3,5	32	3,5	104	7
SPB236/2MA			2	2517	15	44	193	-	45	1	117	7
SPB236/3MA			3	2517	15	63	193	-	45	18	117	6
SPB236/4MA	4	3020	-	82	193	15,5	51	15,5	-	-	3	
SPB236/5MA	5	3535	-	101	193	6	89	6	-	-	3	
SPB236/6MA	6	3535	-	120	193	15,5	89	15,5	-	-	3	
SPB236/8MA	8	3535	-	158	193	34,5	89	34,5	-	-	3	
SPB236/10MA	10	3535	-	196	193	53,5	89	53,5	-	-	3	
SPB250/1MA	250	257	1	2012	20	25	207	3,5	32	3,5	104	7
SPB250/2MA			2	2517	20	44	207	-	45	1	125	7
SPB250/3MA			3	3020	20	63	207	-	51	12	144	6
SPB250/4MA	4	3020	25	82	207	15,5	51	15,5	144	6		
SPB250/5MA	5	3535	-	101	207	6	89	6	-	-	3	
SPB250/6MA	6	3535	-	120	207	15,5	89	15,5	-	-	3	
SPB250/8MA	8	3535	-	158	207	34,5	89	34,5	-	-	3	
SPB250/10MA	10	3535	-	196	207	53,5	89	53,5	-	-	3	

KEILRIEMENSCHLEIBEN FÜR KLEMMBUCHSEN SPB

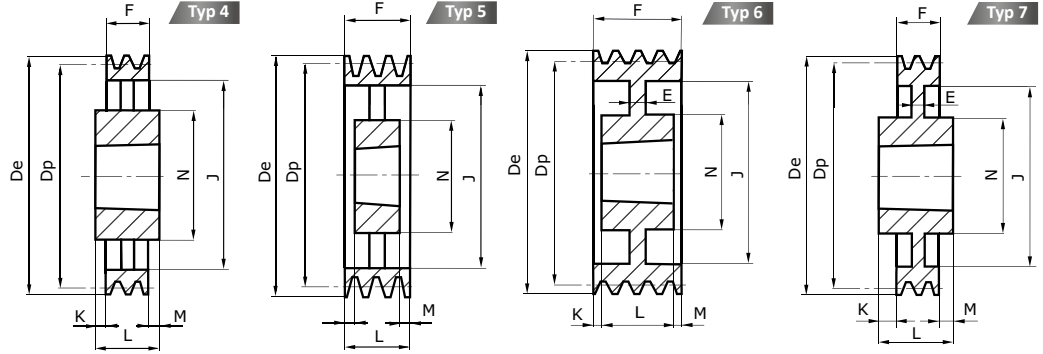

SPB													
Art. Nr.	Dp	De	Z	Buchse	E	F	J	K	L	M	N	Typ	
SPB280/1MA		2012	20	25	237	3,5	32	3,5	104	7			
SPB280/2MA		2517	20	44	237	-	45	1	125	7			
SPB280/3MA		3020	20	63	237	6	51	6	144	6			
SPB280/4MA	280	3020	25	82	237	15,5	51	15,5	144	6			
SPB280/5MA		5	3535	25	101	237	6	89	6	175	6		
SPB280/6MA		6	3535	25	120	237	15,5	89	15,5	175	6		
SPB280/8MA		8	3535	25	158	237	34,5	89	34,5	175	6		
SPB280/10MA		10	3535	30	196	237	53,5	89	53,5	175	6		
SPB300/1MA			2012	20	25	258	3,5	32	3,5	104	7		
SPB300/2MA		2517	20	44	257	-	45	1	125	7			
SPB300/3MA		3020	20	63	257	6	51	6	144	6			
SPB300/4MA	300	3020	25	82	257	-	89	7	175	7			
SPB300/5MA		5	3535	25	101	257	6	89	6	175	6		
SPB300/6MA		6	3535	25	120	257	15,5	89	15,5	175	6		
SPB300/8MA		8	3535	25	158	257	34,5	89	34,5	175	6		
SPB315/1MA			2012	20	25	272	3,5	32	3,5	104	7		
SPB315/2MA			2517	20	44	272	-	45	1	125	7		
SPB315/3MA		3020	20	63	272	6	51	6	144	6			
SPB315/4MA	315	3020	25	82	272	3,5	89	3,5	175	7			
SPB315/5MA		5	3535	25	101	272	6	89	6	175	6		
SPB315/6MA		6	3535	25	120	272	15,5	89	15,5	175	6		
SPB315/8MA		8	3535	25	158	272	34,5	89	34,5	175	6		
SPB315/10MA		10	3535	30	196	272	53,5	89	53,5	175	6		
SPB335/2MA			2517	20	44	292	-	45	1	125	7		
SPB335/3MA		3020	20	63	292	6	51	6	144	6			
SPB335/4MA		3535	25	82	292	3,5	89	3,5	175	7			
SPB335/5MA	335	3535	25	101	292	6	89	6	175	6			
SPB335/6MA		6	3535	25	120	292	15,5	89	15,5	175	6		
SPB335/8MA		8	3535	25	158	292	34,5	89	34,5	175	6		
SPB335/10MA		10	4040	30	196	292	47	102	47	210	6		
SPB355/2MA			3020	15	44	312	3,5	51	3,5	144	7		
SPB355/3MA			3020	15	63	312	6	51	6	144	6		
SPB355/4MA		3535	25	82	312	3,5	89	3,5	175	7			
SPB355/5MA	355	3535	17	101	312	6	89	6	175	6			
SPB355/6MA		6	3535	25	120	312	15,5	89	15,5	175	6		
SPB355/8MA		8	3535	25	158	312	34,5	89	34,5	175	6		
SPB355/10MA		10	4040	30	196	312	47	102	47	210	6		
SPB400/2MA			3020	-	44	357	3,5	51	3,5	150	4		
SPB400/3MA			3535	-	63	357	13	89	13	175	4		
SPB400/4MA		3535	-	82	357	3,5	89	3,5	175	4			
SPB400/5MA	400	5	3535	-	101	357	6	89	6	175	5		
SPB400/6MA		6	3535	-	120	357	15,5	89	15,5	175	5		
SPB400/8MA		8	4040	30	158	357	28	102	28	210	6		
SPB400/10MA		10	4040	30	196	357	47	102	47	210	6		
SPB450/2MA			3020	-	44	407	3,5	51	3,5	150	4		
SPB450/3MA			3535	-	63	407	-	89	26	175	4		
SPB450/4MA		3535	-	82	407	-	89	7	175	4			
SPB450/5MA	450	5	3535	-	101	407	-	89	12	175	5		
SPB450/6MA		6	4040	-	120	407	-	102	18	210	5		
SPB450/8MA		8	4040	-	158	407	28	102	28	210	5		
SPB450/10MA		10	4545	-	196	407	41	114	41	242	5		

SPB													
Art. Nr.	Dp	De	Z	Buchse	E	F	J	K	L	M	N	Typ	
SPB500/2MA		3020	-	44	457	3,5	51	3,5	150	4			
SPB500/3MA		3535	-	63	457	-	89	26	175	4			
SPB500/4MA		3535	-	82	457	-	89	7	175	4			
SPB500/5MA	500	5	3535	-	101	457	-	89	12	175	5		
SPB500/6MA		6	4040	-	120	457	-	102	18	210	5		
SPB500/8MA		8	4040	-	158	457	28	102	28	210	5		
SPB500/10MA		10	4545	-	196	457	41	114	41	242	5		
SPB560/2MA			3030	-	44	517	4	76	28	150	4		
SPB560/3MA			3535	-	63	517	-	89	26	175	4		
SPB560/4MA		3535	-	82	517	-	89	7	175	4			
SPB560/5MA	560	5	4040	-	101	517	-	102	1	210	4		
SPB560/6MA		6	4040	-	120	517	-	102	18	210	5		
SPB560/8MA		8	4545	-	158	517	22	114	22	242	5		
SPB560/10MA		10	4545	-	196	517	41	114	41	242	5		
SPB630/2MA			3030	-	44	587	16	76	16	150	4		
SPB630/3MA			3535	-	63	587	-	89	26	175	4		
SPB630/4MA		3535	-	82	587	-	89	7	175	4			
SPB630/5MA	630	5	4040	-	101	587	-	102	1	210	4		
SPB630/6MA		6	4040	-	120	587	-	102	18	210	5		
SPB630/8MA		8	4545	-	158	587	22	114	22	242	5		
SPB630/10MA		10	4545	-	196	587	41	114	41	242	5		
SPB710/3MA			3535	-	63	664	13	89	13	175	4		
SPB710/4MA			3535	-	82	664	3,5	89	3,5	175	4		
SPB710/5MA	710	5	4040	-	101	664	-	102	1	210	4		
SPB710/6MA		6	4040	-	120	664	9	102	9	210	5		
SPB710/8MA		8	4545	-	158	664	22	114	22	242	5		
SPB710/10MA		10	4545	-	196	664	41	114	41	242	5		
SPB800/3MA			3535	-	63	754	13	89	13	175	4		
SPB800/4MA			4040	-	82	754	10	102	10	210	4		
SPB800/5MA	800	5	4040	-	101	754	-	102	1	210	4		
SPB800/6MA		6	4545	-	120	754	3	114	3	242	5		
SPB800/8MA		8	4545	-	158	754	22	114	22	242	5		
SPB800/10MA		10	4545	-	196	754	41	114	41	242	5		
SPB900/3MA			3535	-	63	854	13	89	13	175	4		
SPB900/4MA			4040	-	82	854	10	102	10	210	4		
SPB900/5MA	900	5	4040	-	101	854	-	102	1	210	4		
SPB900/6MA		6	4545	-	120	854	3	114	3	242	5		
SPB900/8MA		8	4545	-	158	854	22	114	22	242	5		
SPB900/10MA		10	5050	-	196	854	34,5	127	34,5	267	5		
SPB1000/3MA			4040	-	63	954	19,5	102	19,5	210	4		
SPB1000/4MA			4040	-	82	954	10	102	16	210	4		
SPB1000/5MA	1000	5	4545	-	101	954	6,5	114	6,5	242	4		
SPB1000/6MA		6	4545	-	120	954	3	114	3	242	5		
SPB1000/8MA		8	5050	-	158	954	15,5	127	15,5	267	5		
SPB1000/10MA		10	5050	-	196	954	34,5	127	34,5	267	5		
SPB1250/3MA			4040	-	63	1204	19,5	102	19,5	210	4		
SPB1250/4MA			4545	-	82	1204	16	114	16	210	4		
SPB1250/5MA	1250	5	4545	-	101	1204	6,5	114	6,5	242	4		
SPB1250/6MA		6	4545	-	120	1204	3	114	3	242	5		
SPB1250/8MA		8	5050	-	158	1204	15,5	127	15,5	267	5		

Z = Anzahl der Rillen

KEILRIEMENSCHLEIBEN FÜR KLEMMBUCHSEN SPC

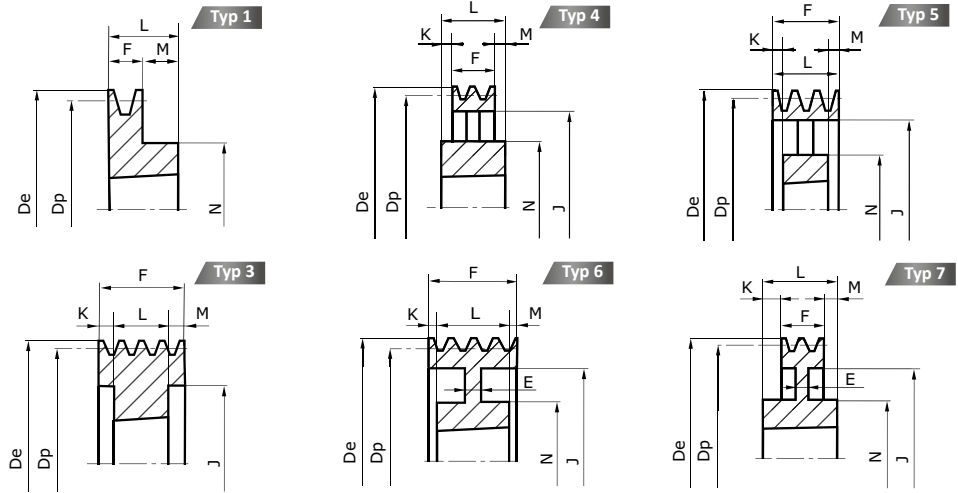

SPC										SPC															
Art. Nr.	Dp	De	Z	Buchse	E	F	J	K	L	M	N	Typ	Art. Nr.	Dp	De	Z	Buchse	E	F	J	K	L	M	N	Typ
SPC200/3MA			3	2517	-	85	144	20	45	20	-	3	SPC335/3MA			3	3535	20	85	279	2	89	2	175	7
SPC200/4MA			4	3020	-	111	144	30	51	30	-	3	SPC335/4MA			4	3535	20	111	279	11	89	11	175	6
SPC200/5MA	200	209,6	5	3535	-	136	144	23,5	89	23,5	-	3	SPC335/5MA	335	344,6	5	3535	20	136	279	23,5	89	23,5	175	6
SPC200/6MA			6	3535	-	162	144	36,5	89	36,5	-	3	SPC335/6MA			6	3535	20	162	279	36,5	89	36,5	175	6
SPC200/8MA			8	3535	-	213	144	62	89	62	-	3	SPC335/8MA			8	4040	50	213	279	55,5	102	55,5	210	6
SPC212/3MA			3	3020	-	85	156	17	51	17	-	3	SPC355/3MA			3	3535	20	85	299	2	89	2	175	7
SPC212/4MA			4	3020	-	111	156	30	51	30	-	3	SPC355/4MA			4	3535	20	111	299	11	89	11	175	6
SPC212/5MA	212	221,6	5	3535	-	136	156	23,5	89	23,5	-	3	SPC355/5MA			5	3535	20	136	299	23,5	89	23,5	175	6
SPC212/6MA			6	3535	-	162	156	36,5	89	36,5	-	3	SPC355/6MA	355	364,6	6	3535	20	162	299	36,5	89	36,5	175	6
SPC212/8MA			8	3535	-	213	156	62	89	62	-	3	SPC355/8MA			8	4040	40	213	299	55,5	102	55,5	210	6
SPC224/3MA			3	3020	-	85	168	17	51	17	-	3	SPC355/10MA			10	4545	-	264	299	75	114	75	-	3
SPC224/4MA			4	3535	-	111	168	11	89	11	-	3	SPC375/3MA			3	3535	25	85	319	2	89	2	175	7
SPC224/5MA	224	233,6	5	3535	-	136	168	23,5	89	23,5	-	3	SPC375/4MA			4	3535	25	111	319	11	89	11	175	6
SPC224/6MA			6	3535	-	162	168	36,5	89	36,5	-	3	SPC375/5MA	375	384,6	5	3535	25	136	319	23,5	89	23,5	175	6
SPC224/8MA			8	3535	-	213	168	62	89	62	-	3	SPC375/6MA			6	4040	30	162	319	30	102	30	210	6
SPC236/3MA			3	3020	-	85	180	17	51	17	-	3	SPC375/8MA			8	4545	30	213	319	49,5	114	49,5	242	6
SPC236/4MA			4	3535	-	111	180	11	89	11	-	3	SPC400/3MA			3	3535	17	85	344	2	89	2	175	7
SPC236/5MA	236	245,6	5	3535	-	136	180	23,5	89	23,5	-	3	SPC400/4MA			4	3535	18	111	344	11	89	11	175	6
SPC236/6MA			6	3535	-	162	180	36,5	89	36,5	-	3	SPC400/5MA			5	3535	15	136	344	23,5	89	23,5	175	6
SPC236/8MA			8	3535	-	213	180	62	89	62	-	3	SPC400/6MA	400	409,6	6	4040	30	162	344	30	102	30	210	6
SPC250/3MA			3	3020	-	85	194	17	51	17	-	3	SPC400/8MA			8	4545	30	213	344	49,5	114	49,5	242	6
SPC250/4MA			4	3535	-	111	194	11	89	11	-	3	SPC400/10MA			10	5050	70	264	344	68,5	127	68,5	267	6
SPC250/5MA	250	259,6	5	3535	-	136	194	23,5	89	23,5	-	3	SPC425/3MA			3	3535	17	85	369	2	89	2	175	7
SPC250/6MA			6	3535	-	162	194	36,5	89	36,5	-	3	SPC425/4MA			4	3535	18	111	369	11	89	11	175	6
SPC250/8MA			8	3535	-	213	194	62	89	62	-	3	SPC425/5M1	425	434,6	5	3535	20	136	369	23,5	89	23,5	175	6
SPC250/10MA			10	4040	-	264	194	81	102	81	-	3	SPC425/6MA			6	4040	30	162	369	30	102	24	210	6
SPC265/3MA			3	3535	-	85	209	-	89	4	175	1	SPC425/8MA			8	4545	30	213	369	49,5	114	49,5	240	6
SPC265/4MA			4	3535	-	111	209	11	89	11	-	3	SPC450/3MA			3	3535	-	85	394	2	89	2	175	4
SPC265/5MA	265	274,6	5	3535	-	136	209	23,5	89	23,5	-	3	SPC450/4MA			4	3535	-	111	394	11	89	11	175	5
SPC265/6MA			6	3535	-	162	209	36,5	89	36,5	-	3	SPC450/5MA			5	4040	-	136	394	17	102	17	210	5
SPC265/8MA			8	3535	-	213	209	62	89	62	-	3	SPC450/6MA	450	459,6	6	4545	30	162	394	24	114	24	242	6
SPC280/3MA			3	3535	-	85	224	-	89	4	175	1	SPC450/8MA			8	5050	30	213	394	43	127	43	267	6
SPC280/4MA			4	3535	18	111	224	11	89	11	175	6	SPC450/10MA			10	5050	40	264	394	68,5	127	68,5	267	6
SPC280/5MA	280	289,6	5	3535	-	136	224	23,5	89	23,5	-	3	SPC475/3MA			3	3535	-	85	419	2	89	2	175	4
SPC280/6MA			6	3535	20	162	224	36,5	89	36,5	175	6	SPC475/4MA			4	3535	-	111	419	11	89	11	175	5
SPC280/8MA			8	3535	-	213	224	62	89	62	-	3	SPC475/5MA	475	484,6	5	4040	-	136	419	17	102	17	210	5
SPC280/10MA			10	4040	-	264	224	81	102	81	-	3	SPC475/6MA			6	4545	30	162	419	24	114	24	242	6
SPC300/3MA			3	3535	20	85	244	2	89	2	175	7	SPC475/8MA			8	5050	30	213	419	43	127	43	267	6
SPC300/4MA			4	3535	20	111	244	11	89	11	175	6	SPC500/3MA			3	3535	-	85	444	2	89	2	175	4
SPC300/5MA	300	309,6	5	3535	20	136	244	23,5	89	23,5	175	6	SPC500/4MA			4	3535	-	111	444	11	89	11	175	5
SPC300/6MA			6	3535	20	162	244	36,5	89	36,5	175	6	SPC500/5MA			5	4040	-	136	444	17	102	17	210	5
SPC300/8MA			8	4040	-	213	244	55,5	102	55,5	-	3	SPC500/6MA	500	509,6	6	4545	-	162	444	24	114	24	242	5
SPC300/10MA			10	4545	-	264	244	75	114	75	-	3	SPC500/8MA			8	5050	30	213	444	43	127	43	267	6
SPC315/3MA			3	3535	20	85	259	2	89	2	175	7	SPC500/10MA			10	5050	40	264	444	68,5	127	68,5	267	6
SPC315/4MA			4	3535	20	111	259	11	89	11	175	6	SPC530/3MA			3	3535	-	85	474	2	89	2	175	4
SPC315/5MA	315	324,6	5	3535	20	136	259	23,5	89	23,5	175	6	SPC530/4MA			4	4040	-	111	474	4,5	102	4,5	210	5
SPC315/6MA			6	3535	20	162	259	36,5	89	36,5	175	6	SPC530/5MA	530	539,6	5	4545	-	136	474	11	114	11	240	5
SPC315/8MA			8	4040	-	213	259	55,5	102	55,5	-	3	SPC530/6MA			6	5050	-	162	474	17,5	114	17,5	265	5
SPC315/10MA			10	4545	-	264	259	75	114	75	-	3	SPC530/8MA			8	5050	30	213	474	43	127	43	267	6

Z = Anzahl der Rillen



KEILRIEMENSCHLEIBEN FÜR KLEMMBUCHSEN SPC

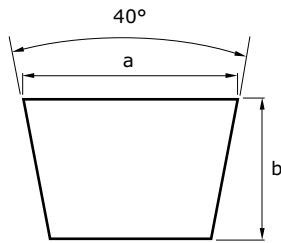
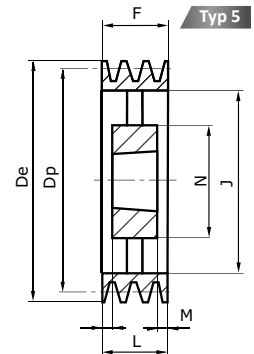
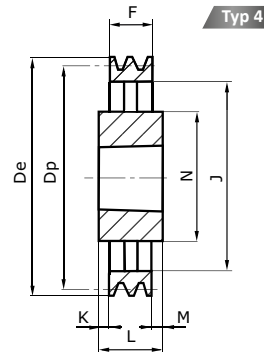

Riemenquerschnitt	a mm	b mm
Z	10	6
SPZ	9,7	8
XPZ	9	8
A	13	8
SPA	12,7	10
XPA	11,5	9
B	17	11
SPB	16,3	13
XPB	15,3	13
C	22	14
SPC	22	18
XPC	22	17

SPC												
Art. Nr.	Dp	De	Z	Buchse	E	F	J	K	L	M	N	Typ
SPC560/3MA			3	3535	-	85	504	2	89	2	175	4
SPC560/4MA			4	4040	-	111	504	4,5	102	4,5	210	5
SPC560/5MA	560	569,6	5	4545	-	136	504	11	114	11	242	5
SPC560/6MA			6	5050	-	162	504	17,5	127	17,5	267	5
SPC560/8MA			8	5050	-	213	504	43	127	43	267	5
SPC560/10MA			10	5050	-	264	504	68,5	127	68,5	267	5
SPC630/3MA			3	3535	-	85	574	8,5	102	8,5	210	4
SPC630/4MA			4	4545	-	111	574	1,5	114	1,5	242	4
SPC630/5MA	630	639,6	5	5050	-	136	574	4,5	127	4,5	267	5
SPC630/6MA			6	5050	-	162	574	17,5	127	17,5	267	5
SPC630/8MA			8	5050	-	213	574	43	127	43	267	5
SPC630/10MA			10	5050	-	264	574	68,5	127	68,5	267	5
SPC710/4MA			4	5050	-	111	654	8	127	8	267	4
SPC710/5MA			5	5050	-	136	654	4,5	127	4,5	267	5
SPC710/6MA	710	719,6	6	5050	-	162	654	17,5	127	17,5	267	5
SPC710/8MA			8	5050	-	213	654	43	127	43	267	5
SPC710/10MA			10	5050	-	264	654	68,5	127	68,5	267	5
SPC800/3MA			3	4545	-	85	737	14,5	114	14,5	242	4
SPC800/4MA			4	5050	-	111	737	8	127	8	267	4
SPC800/5MA	800	809,6	5	5050	-	136	737	4,5	127	4,5	267	5
SPC800/6MA			6	5050	-	162	737	17,5	127	17,5	267	5
SPC800/8MA			8	5050	-	213	737	43	127	43	267	5
SPC800/10MA			10	5050	-	264	737	68,5	127	68,5	267	5
SPC1000/3MA			3	5050	-	85	937	21	127	21	267	4
SPC1000/4MA			4	5050	-	111	937	8	127	8	267	4
SPC1000/5MA	1000	1009,6	5	5050	-	136	937	4,5	127	4,5	267	5
SPC1000/6MA			6	5050	-	162	937	17,5	127	17,5	267	5
SPC1000/8MA			8	5050	-	213	937	43	127	43	267	5
SPC1000/10MA			10	5050	-	264	937	68,5	127	68,5	267	5
SPC1250/3MA			3	5050	-	85	1187	21	127	21	267	4
SPC1250/4MA			4	5050	-	111	1187	8	127	8	267	4
SPC1250/5MA	1250	1259,6	5	5050	-	136	1187	4,5	127	4,5	267	5
SPC1250/6MA			6	5050	-	162	1187	17,5	127	17,5	267	5
SPC1250/8MA			8	5050	-	213	1187	43	127	43	267	5
SPC1250/10MA			10	5050	-	264	1187	68,5	127	68,5	267	5

Z = Anzahl der Rillen

Alle unsere Riemenscheiben mit Vollnaben und für Klemmbuchse werden gemäß den Normen ISO 4183 und DIN 2211 hergestellt.

Material: Guss EN-GJL-250 UNI EN 1561 + Phosphorierung Statisch ausgewuchtete Riemenscheiben, maximale Geschwindigkeit 30 m/Sekunde.



KEILRIEMENSCHLEIBEN FÜR SPANNSÄTZE SPA

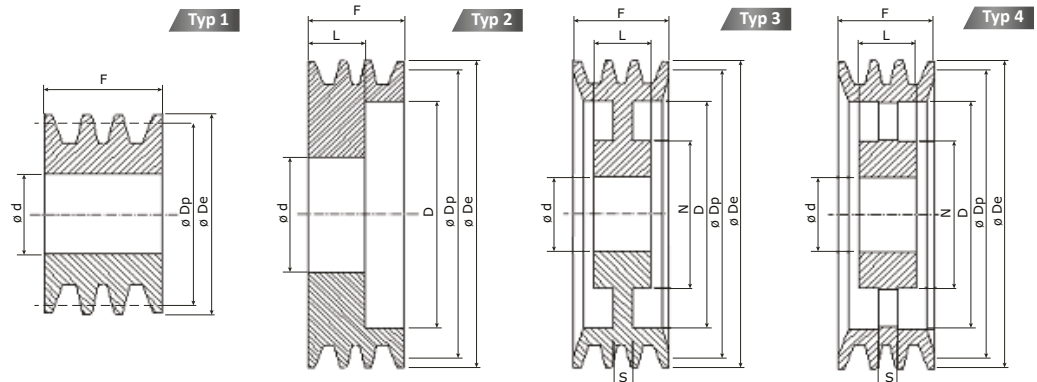

Art. Nr.	Dp	De	SPA							Typ	**ØdH8		
			Z	N	L	D	S	F	Ø55		Ø65	Ø80	
SPAK090/155	90	95,5	1	-	-	-	-	20	1	55	-	-	
SPAK090/255			2	-	-	-	-	35	1	55	-	-	
SPAK090/355			3	-	-	-	-	50	1	55	-	-	
SPAK090/455			4	-	-	-	-	65	1	55	-	-	
SPAK090/555			5	-	-	-	-	80	1	55	-	-	
SPAK095/155	95	100,5	1	-	-	-	-	20	1	55	-	-	
SPAK095/255			2	-	-	-	-	35	1	55	-	-	
SPAK095/355			3	-	-	-	-	50	1	55	-	-	
SPAK095/455			4	-	-	-	-	65	1	55	-	-	
SPAK095/555			5	-	-	-	-	80	1	55	-	-	
SPAK100/1..	100	105,5	1	-	-	-	-	20	1	55	65	-	
SPAK100/2..			2	-	-	-	-	35	1	55	65	-	
SPAK100/3..			3	-	-	-	-	50	1	55	65	-	
SPAK100/4..			4	-	-	-	-	65	1	55	65	-	
SPAK100/5..			5	-	-	-	-	80	1	55	65	-	
SPAK105/1..	105	110,5	1	-	-	-	-	20	1	55	65	-	
SPAK105/2..			2	-	-	-	-	35	1	55	65	-	
SPAK105/3..			3	-	-	-	-	50	1	55	65	-	
SPAK105/4..			4	-	-	-	-	65	1	55	65	-	
SPAK105/5..			5	-	-	-	-	80	1	55	65	-	
SPAK112/1..	112	117,5	1	-	-	-	-	20	1	55	65	-	
SPAK112/2..			2	-	27	79	-	35	2	55	65	-	
SPAK112/3..			3	-	27	79	-	50	2	55	65	-	
SPAK112/4..			4	-	27	79	-	65	2	55	65	-	
SPAK112/5..			5	-	27	79	27	80	3	55	65	-	
SPAK120/1..	120	125,5	1	-	-	-	-	20	1	55	65	80	
SPAK120/2..			2	-	27	88	-	35	2	55	65	80	
SPAK120/3..			3	-	27	88	-	50	2	55	65	80	
SPAK120/4..			4	-	27	88	-	65	2	55	65	80	
SPAK120/5..			5	-	27	88	27	80	3	55	65	80	
SPAK125/1..	125	130,5	1	-	-	-	-	20	1	55	65	80	
SPAK125/2..			2	-	27	92	-	35	2	55	65	80	
SPAK125/3..			3	-	27	92	-	50	2	55	65	80	
SPAK125/4..			4	-	27	92	-	65	2	55	65	80	
SPAK125/5..			5	-	27	92	27	80	3	55	65	80	
SPAK130/1..	130	135,5	1	-	-	-	-	20	1	55	65	80	
SPAK130/2..			2	-	27	97	-	35	2	55	65	80	
SPAK130/3..			3	-	27	97	-	50	2	55	65	80	
SPAK130/4..			4	-	27	97	-	65	2	55	65	80	
SPAK130/5..			5	-	27	97	27	80	3	55	65	80	
SPAK140/1..	140	145,5	1	-	-	-	-	20	1	55	65	80	
SPAK140/2..			2	-	27	107	-	35	2	55	65	08	
SPAK140/3..			3	-	27	107	-	50	2	55	65	80	
SPAK140/4..			4	-	27	107	-	65	2	55	65	80	
SPAK140/5..			5	-	27	107	27	80	3	55	65	80	

Z = Anzahl der Rillen

.. = Durchmesser der Bohrung des Keilriemenscheibe (Gehäuse für Spannsatz)

KEILRIEMENSCHLEIBEN FÜR SPANNSÄTZE SPA

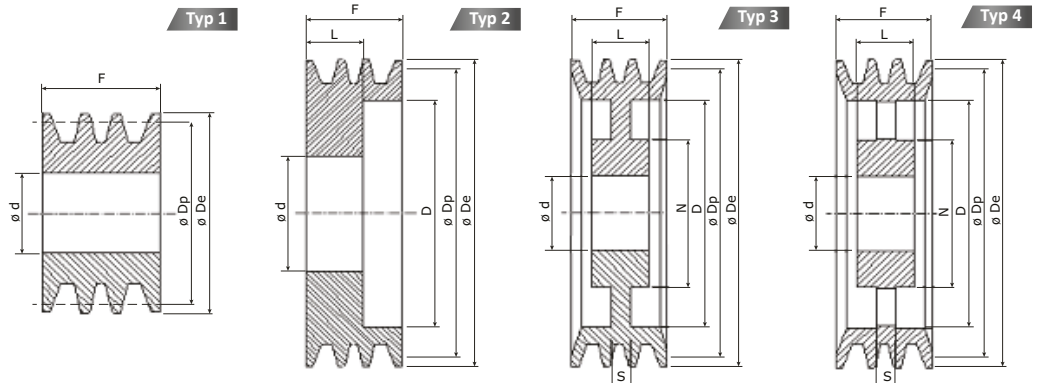

SPA											SPA														
Art. Nr.	Dp	De	Z	N	L	D	S	F	Typ	**ØdH8 Ø55 Ø65 Ø80	Art. Nr.	Dp	De	Z	N	L	D	S	F	Typ	**ØdH8 Ø55 Ø65 Ø80				
SPAK150/1..			1	-	-	-	-	20	1	55	65	80	SPAK300/1..		1	130	20	267	14	20	4	55	65	80	
SPAK150/2..			2	-	27	117	-	35	2	55	65	80	SPAK300/2..		2	130	27	267	14	35	4	55	65	80	
SPAK150/3..	150	155,5	3	-	27	117	-	50	2	55	65	80	SPAK300/3..	300	305,5	3	130	27	267	14	50	4	55	65	80
SPAK150/4..			4	-	27	117	-	65	2	55	65	80	SPAK300/4..			4	130	27	267	14	65	4	-	65	80
SPAK150/5..			5	-	27	117	27	80	3	55	65	80	SPAK300/5..			5	130	27	267	14	80	4	-	65	80
SPAK160/1..			1	-	-	-	-	20	1	55	65	80	SPAK315/1..			1	130	20	282	14	20	4	55	65	80
SPAK160/2..			2	-	27	127	-	35	2	55	65	80	SPAK315/2..			2	130	27	282	14	35	4	55	65	80
SPAK160/3..	160	165,5	3	-	27	127	-	50	2	55	65	80	SPAK315/3..	315	320,5	3	130	27	282	14	50	4	55	65	80
SPAK160/4..			4	-	27	127	-	65	2	55	65	80	SPAK315/4..			4	130	27	282	14	65	4	-	65	80
SPAK160/5..			5	-	27	127	27	80	3	55	65	80	SPAK315/2..			5	130	27	282	16	80	4	-	65	80
SPAK170/1..			1	-	-	-	-	20	1	55	65	80	SPAK355/1..			1	130	20	317	14	20	4	55	65	80
SPAK170/2..			2	-	27	137	27	35	3	55	65	80	SPAK355/2..			2	130	27	317	14	35	4	55	65	80
SPAK170/3..	170	175,5	3	-	27	137	27	50	3	55	65	80	SPAK355/3..	355	360,5	3	130	27	317	14	50	4	55	65	80
SPAK170/4..			4	-	27	137	27	65	3	55	65	80	SPAK355/4..			4	130	27	317	18	65	4	-	65	80
SPAK170/5..			5	-	27	137	27	80	3	55	65	80	SPAK355/5..			5	130	27	317	20	80	4	-	65	80
SPAK180/1..			1	-	-	-	-	20	1	55	65	80	SPAK380/1..			1	130	20	347	14	20	4	-	65	80
SPAK180/2..			2	-	27	147	27	35	3	55	65	80	SPAK380/2..			2	130	27	347	14	35	4	-	65	80
SPAK180/3..	180	185,5	3	-	27	147	27	50	3	55	65	80	SPAK380/3..	380	385,5	3	130	27	347	14	50	4	-	65	80
SPAK180/4..			4	-	27	147	27	65	3	55	65	80	SPAK380/4..			4	130	27	347	18	65	4	-	65	80
SPAK180/5..			5	-	27	147	27	80	3	55	65	80	SPAK380/5..			5	130	27	347	20	80	4	-	65	80
SPAK190/1..			1	-	-	-	-	20	1	55	65	80	SPAK400/1..			1	130	20	367	14	20	4	-	65	80
SPAK190/2..			2	120	27	157	12	35	3	55	65	80	SPAK400/2..			2	130	27	367	14	35	4	-	65	80
SPAK190/3..	190	195,5	3	120	27	157	12	50	3	55	65	80	SPAK400/3..	400	405,5	3	130	27	367	16	50	4	-	65	80
SPAK190/4..			4	120	27	157	12	65	3	55	65	80	SPAK400/4..			4	130	27	367	20	65	4	-	65	80
SPAK190/5..			5	120	27	157	12	80	3	55	65	80	SPAK400/5..			5	130	27	367	24	80	4	-	65	80
SPAK200/1..			1	-	-	-	-	20	1	55	65	80	SPAK425/1..			1	130	20	392	14	20	4	-	65	80
SPAK200/2..			2	120	27	167	12	35	3	55	65	80	SPAK425/2..			2	130	27	392	14	35	4	-	65	80
SPAK200/3..	200	205,5	3	120	27	167	14	50	3	55	65	80	SPAK425/3..	425	430,5	3	130	27	392	16	50	4	-	65	80
SPAK200/4..			4	120	27	167	14	65	3	55	65	80	SPAK425/4..			4	130	27	392	20	65	4	-	65	80
SPAK200/5..			5	120	27	167	14	80	3	55	65	80	SPAK425/5..			5	130	27	392	24	80	4	-	65	80
SPAK225/1..			1	120	20	192	12	20	3	55	65	80	SPAK450/1..			1	130	20	417	14	20	4	-	65	80
SPAK225/2..			2	120	27	192	12	35	3	55	65	80	SPAK450/2..			2	130	27	417	14	35	4	-	65	80
SPAK225/3..	225	230,5	3	120	27	192	14	50	3	55	65	80	SPAK450/3..	450	455,5	3	130	27	417	16	50	4	-	65	80
SPAK225/4..			4	120	27	192	14	65	3	-	65	80	SPAK450/4..			4	130	27	417	20	65	4	-	65	80
SPAK225/5..			5	120	27	192	14	80	3	-	65	80	SPAK450/5..			5	130	27	417	24	80	4	-	65	80
SPAK250/1..			1	130	20	217	14	20	4	55	65	80	SPAK500/1..			1	130	20	467	14	20	4	-	65	80
SPAK250/2..			2	130	27	217	14	35	4	55	65	80	SPAK500/2..			2	130	27	467	16	35	4	-	65	80
SPAK250/3..	250	255,5	3	130	27	217	14	50	4	55	65	80	SPAK500/3..	500	505,5	3	130	27	467	20	50	4	-	65	80
SPAK250/4..			4	130	27	217	14	65	4	-	65	80	SPAK500/4..			4	130	27	467	25	65	4	-	65	80
SPAK250/5..			5	130	27	217	14	80	4	-	65	80	SPAK500/5..			5	130	27	467	25	80	4	-	65	80
SPAK280/1..			1	130	20	247	14	20	4	55	65	80	SPAK630/1..			1	130	20	597	16	20	4	-	65	80
SPAK280/2..			2	130	27	247	14	35	4	55	65	80	SPAK630/2..			2	130	27	597	20	35	4	-	65	80
SPAK280/3..	280	285,5	3	130	27	247	14	50	4	55	65	80	SPAK630/3..	630	635,5	3	130	27	597	22	50	4	-	65	80
SPAK280/4..			4	130	27	247	14	65	4	-	65	80	SPAK630/4..			4	130	27	597	25	65	4	-	65	80
SPAK280/5..			5	120	27	247	14	80	4	-	65	80	SPAK630/5..			5	130	27	597	25	80	4	-	65	80

Z = Anzahl der Rillen

* Ausführung in Stahl

.. = Durchmesser der Bohrung der Riemenscheibe (Gehäuse für Spannsatz)



KEILRIEMENSCHLEIBEN FÜR SPANNSÄTZE SPB

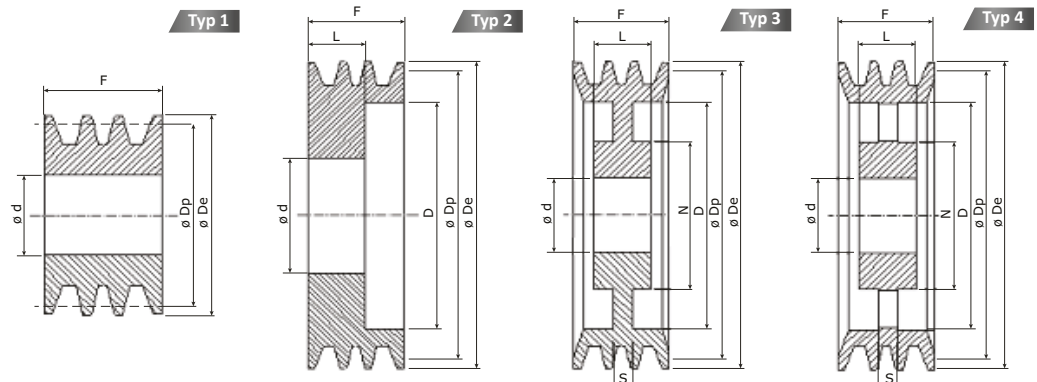

Art. Nr.	Dp	De	SPB							Typ	**ØdH8		
			Z	N	L	D	S	F	Ø55		Ø65	Ø80	
SPBK90/155			1	-	-	-	-	25	1	55	-	-	
SPBK90/255			2	-	27	-	-	44	1	55	-	-	
SPBK90/355	90	97	3	-	27	-	-	63	1	55	-	-	
SPBK90/455			4	-	27	-	-	82	1	55	-	-	
SPBK90/555			5	-	27	-	-	101	1	55	-	-	
SPBK105/155			1	-	-	-	-	25	1	55	-	-	
SPBK105/255			2	-	27	65	-	44	2	55	-	-	
SPBK105/355	105	112	3	-	27	65	-	63	2	55	-	-	
SPBK105/455			4	-	27	65	-	82	2	55	-	-	
SPBK105/555			5	-	27	65	-	101	2	55	-	-	
SPBK112/155			1	-	-	-	-	25	1	55	-	-	
SPBK112/255			2	-	27	70	-	44	2	55	-	-	
SPBK112/355	112	119	3	-	27	70	-	63	2	55	-	-	
SPBK112/455			4	-	27	70	-	82	2	55	-	-	
SPBK112/555			5	-	27	70	-	101	2	55	-	-	
SPBK120/1..			1	-	-	-	-	25	1	55	65	-	
SPBK120/2..			2	-	27	78	-	44	2	55	65	-	
SPBK120/3..	120	127	3	-	27	78	-	63	2	55	65	-	
SPBK120/4..			4	-	27	78	-	82	2	55	65	-	
SPBK120/5..			5	-	27	78	-	101	2	55	65	-	
SPBK125/1..			1	-	-	-	-	25	1	55	65	-	
SPBK125/2..			2	-	27	83	-	44	2	55	65	-	
SPBK125/3..	125	132	3	-	27	83	-	63	2	55	65	-	
SPBK125/4..			4	-	27	83	-	82	2	55	65	-	
SPBK125/5..			5	-	27	83	-	101	2	55	65	-	
SPBK130/1..			1	-	-	-	-	25	1	55	65	80	
SPBK130/2..			2	-	27	90	-	44	2	55	65	80	
SPBK130/3..	130	137	3	-	27	90	-	63	2	55	65	80	
SPBK130/4..			4	-	27	90	-	82	2	55	65	80	
SPBK130/5..			5	-	27	90	-	101	2	55	65	80	
SPBK140/1..			1	-	-	-	-	25	1	55	65	80	
SPBK140/2..			2	-	27	98	-	44	2	55	65	80	
SPBK140/3..	140	147	3	-	27	98	-	63	2	55	65	80	
SPBK140/4..			4	-	27	98	-	82	2	55	65	80	
SPBK140/5..			5	-	27	98	-	101	2	55	65	80	
SPBK150/1..			1	-	-	-	-	25	1	55	65	80	
SPBK150/2..			2	-	27	108	-	44	2	55	65	80	
SPBK150/3..	150	157	3	-	27	108	-	63	2	55	65	80	
SPBK150/4..			4	-	27	108	-	82	2	55	65	80	
SPBK150/5..			5	-	27	108	-	101	2	55	65	80	
SPBK160/1..			1	-	-	-	-	25	1	55	65	80	
SPBK160/2..			2	-	27	118	-	44	2	55	65	80	
SPBK160/3..	160	167	3	-	27	118	-	63	2	55	65	80	
SPBK160/4..			4	-	27	118	-	82	2	55	65	80	
SPBK160/5..			5	-	27	118	-	101	2	55	65	80	

Z = Anzahl der Rillen

.. = Durchmesser der Bohrung des Keilriemenscheibe (Gehäuse für Spannsatz)

KEILRIEMENSCHLEIBEN FÜR SPANNSÄTZE SPB

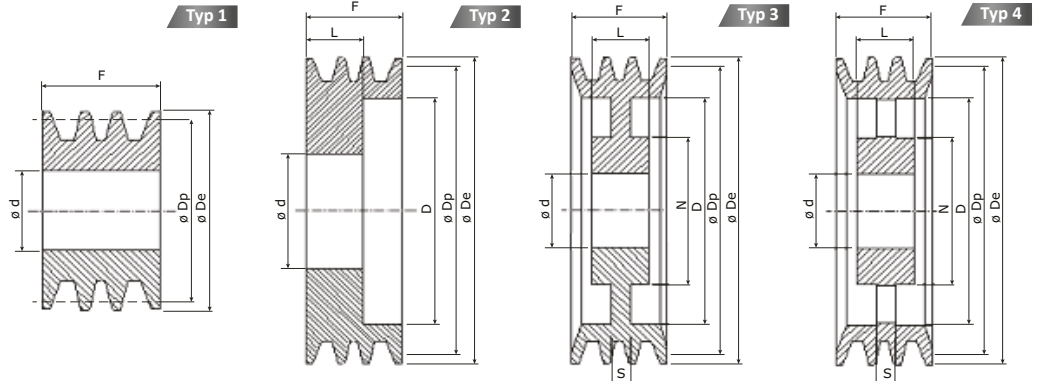

SPB											SPB														
Art. Nr.	Dp	De	Z	N	L	D	S	F	Typ	**ØdH8 Ø55 Ø65 Ø80	Art. Nr.	Dp	De	Z	N	L	D	S	F	Typ	**ØdH8 Ø55 Ø65 Ø80				
SPBK170/1..			1	-	-	-	-	25	1	55	65	80	SPBK280/1..	1	120	25	238	16	25	3	55	65	80		
SPBK170/2..			2	-	27	128	27	44	3	55	65	80	SPBK280/2..	2	120	27	238	16	44	3	55	65	80		
SPBK170/3..	170	177	3	-	27	128	27	63	3	55	65	80	SPBK280/3..	280	287	3	120	27	238	16	63	3	-	65	80
SPBK170/4..			4	-	27	128	27	82	3	55	65	80	SPBK280/4..			4	120	27	238	16	82	3	-	65	80
SPBK170/5..			5	-	27	128	27	101	3	55	65	80	SPBK280/5..			5	130	27	238	16	101	3	-	65	80
SPBK180/1..			1	-	-	-	-	25	1	55	65	80	SPBK300/1..			1	130	25	258	15	25	4	55	65	80
SPBK180/2..			2	-	27	138	27	44	3	55	65	80	SPBK300/2..			2	130	27	258	15	44	4	55	65	80
SPBK180/3..	180	187	3	-	27	138	27	63	3	55	65	80	SPBK300/3..	300	307	3	130	27	258	18	63	4	-	65	80
SPBK180/4..			4	-	27	138	27	82	3	55	65	80	SPBK300/4..			4	130	27	258	20	82	4	-	65	80
SPBK180/5..			5	-	27	138	27	101	3	55	65	80	SPBK300/5..			5	130	27	258	22	101	4	-	65	80
SPBK190/1..			1	-	-	-	-	25	1	55	65	80	SPBK315/1..			1	130	25	273	15	25	4	55	65	80
SPBK190/2..			2	-	27	148	27	44	3	55	65	80	SPBK315/2..			2	130	27	273	15	44	4	55	65	80
SPBK190/3..	190	197	3	-	27	148	27	63	3	55	65	80	SPBK315/3..	315	322	3	130	27	273	18	63	4	-	65	80
SPBK190/4..			4	-	27	148	27	82	3	55	65	80	SPBK315/4..			4	130	27	273	20	82	4	-	65	80
SPBK190/5..			5	-	27	148	27	101	3	55	65	80	SPBK315/5..			5	130	27	273	22	101	4	-	65	80
SPBK200/1..			1	-	-	-	-	25	1	55	65	80	SPBK355/1..			1	130	25	308	16	25	4	55	65	80
SPBK200/2..			2	120	27	158	15	44	3	55	65	80	SPBK355/2..			2	130	27	308	18	44	4	-	65	80
SPBK200/3..	200	207	3	120	27	158	15	63	3	55	65	80	SPBK355/3..	355	362	3	130	27	308	22	63	4	-	65	80
SPBK200/4..			4	120	27	158	15	82	3	55	65	80	SPBK355/4..			4	130	27	308	22	82	4	-	65	80
SPBK200/5..			5	120	27	158	15	101	3	55	65	80	SPBK355/5..			5	130	27	308	24	101	4	-	65	80
SPBK200/6..			6	120	27	158	18	120	3	55	65	80	SPBK380/1..			1	130	25	338	20	25	4	-	65	80
SPBK212/1..			1	120	25	170	15	25	3	55	65	80	SPBK380/2..			2	130	27	338	20	44	4	-	65	80
SPBK212/2..			2	120	27	170	15	44	3	55	65	80	SPBK380/3..	380	387	3	130	27	338	22	63	4	-	65	80
SPBK212/3..	212	219	3	120	27	170	15	63	3	55	65	80	SPBK380/4..			4	130	27	338	24	82	4	-	65	80
SPBK212/4..			4	120	27	170	15	82	3	-	65	80	SPBK380/5..			5	130	27	338	24	101	4	-	65	80
SPBK212/5..			5	120	27	170	15	101	3	-	65	80	SPBK400/1..			1	130	25	358	20	25	4	-	65	80
SPBK225/1..			1	120	25	183	15	25	3	55	65	80	SPBK400/2..			2	130	27	358	20	44	4	-	65	80
SPBK225/2..			2	120	27	183	15	44	3	55	65	80	SPBK400/3..	400	407	3	130	27	358	22	63	4	-	65	80
SPBK225/3..	225	232	3	120	27	183	15	63	3	55	65	80	SPBK400/4..			4	130	27	358	24	82	4	-	65	80
SPBK225/4..			4	120	27	183	15	82	3	-	65	80	SPBK400/5..			5	130	27	358	24	101	4	-	65	80
SPBK225/5..			5	120	27	183	15	101	3	-	65	80	SPBK425/1..			1	130	25	383	22	25	4	-	65	80
SPBK225/6..			6	120	27	183	18	120	3	-	65	80	SPBK425/2..			2	130	27	383	22	44	4	-	65	80
SPBK240/1..			1	120	25	198	16	25	3	55	65	80	SPBK425/3..	425	432	3	130	27	383	24	63	4	-	65	80
SPBK240/2..			2	120	27	198	16	44	3	55	65	80	SPBK425/4..			4	130	27	383	24	82	4	-	65	80
SPBK240/3..	240	247	3	120	27	198	16	63	3	55	65	80	SPBK425/5..			5	130	27	383	24	101	4	-	65	80
SPBK240/4..			4	120	27	198	16	82	3	-	65	80	SPBK450/1..			1	130	25	408	20	25	4	-	65	80
SPBK240/5..			5	130	27	198	16	101	3	-	65	80	SPBK450/2..			2	130	27	408	20	44	4	-	65	80
SPBK250/1..			1	120	25	208	16	25	3	55	65	80	SPBK450/3..	450	457	3	130	27	408	24	63	4	-	65	80
SPBK250/2..			2	120	27	208	16	44	3	55	65	80	SPBK450/4..			4	130	27	408	24	82	4	-	65	80
SPBK250/3..	250	257	3	120	27	208	16	63	3	55	65	80	SPBK450/5..			5	130	27	408	24	101	4	-	65	80
SPBK250/4..			4	120	27	208	16	82	3	-	65	80	SPBK500/1..			1	130	25	458	20	25	4	-	65	80
SPBK250/5..			5	130	27	208	16	101	3	-	65	80	SPBK500/2..			2	130	27	458	20	44	4	-	65	80
SPBK250/6..			6	130	27	208	18	120	3	-	65	80	SPBK500/3..	500	507	3	130	27	458	24	63	4	-	65	80
													SPBK500/4..			4	130	27	458	24	82	4	-	65	80
													SPBK500/5..			5	130	27	458	24	101	4	-	65	80

Z = Anzahl der Rillen
 * Ausführung in Stahl
 .. = Durchmesser der Bohrung der Riemenscheibe (Gehäuse für Spannsatz)



KEILRIEMENSCHLEIBEN FÜR SPANNSÄTZE SPC

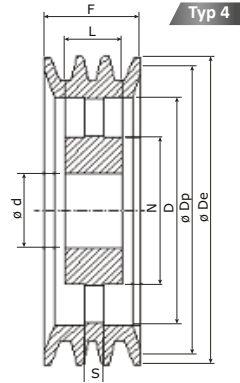
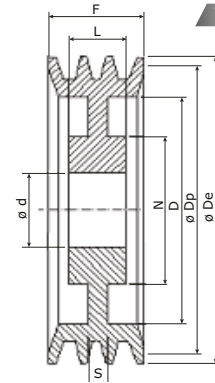
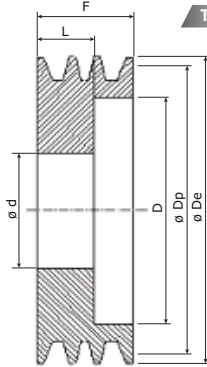
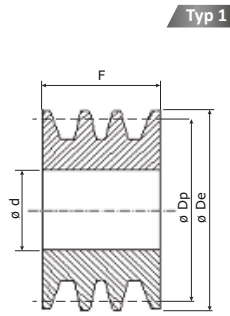

SPC										**ØdH8		
Art. Nr.	Dp	De	Z	N	L	D	S	F	Typ	Ø55	Ø65	Ø80
SPCK130/1..			1	-	25	75	-	34	2	55	65	-
SPCK130/2..			2	-	27	75	-	59,5	2	55	65	-
SPCK130/3..	130	139,6	3	-	27	75	-	85	2	55	65	-
SPCK130/4..			4	-	27	75	-	111	2	55	65	-
SPCK130/5..			5	-	27	75	-	136	2	55	65	-
SPCK140/1..			1	-	25	83	-	34	2	55	65	-
SPCK140/2..			2	-	27	83	-	59,5	2	55	65	-
SPCK140/3..	140	149,6	3	-	27	83	-	85	2	55	65	-
SPCK140/4..			4	-	27	83	-	111	2	55	65	-
SPCK140/5..			5	-	27	83	-	136	2	55	65	-
SPCK150/1..			1	-	25	93	-	34	2	55	65	80
SPCK150/2..			2	-	27	93	-	59,5	2	55	65	80
SPCK150/3..	150	159,6	3	-	27	93	-	85	2	55	65	80
SPCK150/4..			4	-	27	93	-	111	2	55	65	80
SPCK150/5..			5	-	27	93	-	136	2	55	65	80
SPCK160/1..			1	-	25	103	-	34	2	55	65	80
SPCK160/2..			2	-	27	103	-	59,5	2	55	65	80
SPCK160/3..	160	169,6	3	-	27	103	-	85	2	55	65	80
SPCK160/4..			4	-	27	103	-	111	3	55	65	80
SPCK160/5..			5	-	27	103	-	136	3	55	65	80
SPCK170/1..			1	-	25	113	-	34	2	55	65	80
SPCK170/2..			2	-	27	113	-	59,5	2	55	65	80
SPCK170/3..	170	179,6	3	-	27	113	-	85	2	55	65	80
SPCK170/4..			4	-	27	113	-	111	3	55	65	80
SPCK170/5..			5	-	27	113	-	136	3	55	65	80
SPCK180/1..			1	-	25	123	-	34	2	55	65	80
SPCK180/2..			2	-	27	123	-	59,5	2	55	65	80
SPCK180/3..	180	189,6	3	-	27	123	-	85	2	55	65	80
SPCK180/4..			4	-	27	123	-	111	3	55	65	80
SPCK180/5..			5	-	27	123	-	136	3	55	65	80
SPCK190/1..			1	-	25	133	-	34	2	55	65	80
SPCK190/2..			2	-	27	133	-	59,5	2	55	65	80
SPCK190/3..	190	199,6	3	-	27	133	-	85	2	55	65	80
SPCK190/4..			4	-	27	133	-	111	3	55	65	80
SPCK190/5..			5	-	27	133	-	136	3	55	65	80
SPCK200/1..			1	-	25	143	-	34	2	55	65	80
SPCK200/2..			2	-	27	143	-	59,5	2	55	65	80
SPCK200/3..	200	209,6	3	-	27	143	-	85	2	55	65	80
SPCK200/4..			4	-	27	143	-	111	3	55	65	80
SPCK200/5..			5	-	27	143	-	136	3	55	65	80
SPCK225/1..			1	120	25	168	18	34	3	-	65	80
SPCK225/2..			2	120	27	168	18	59,5	3	-	65	80
SPCK225/3..	225	234,6	3	120	27	168	25	85	3	-	65	80
SPCK225/4..			4	120	27	168	25	111	3	-	65	80
SPCK225/5..			5	120	27	168	25	136	3	-	65	80

SPC										**ØdH8		
Art. Nr.	Dp	De	Z	N	L	D	S	F	Typ	Ø55	Ø65	Ø80
SPCK250/1..			1	120	25	193	18	34	3	-	65	80
SPCK250/2..			2	120	27	193	18	59,5	3	-	65	80
SPCK250/3..	250	259,6	3	120	27	193	25	85	3	-	65	80
SPCK250/4..			4	130	27	193	25	111	3	-	65	80
SPCK250/5..			5	130	27	193	25	136	3	-	65	80
SPCK280/1..			1	120	27	223	18	34	3	-	65	80
SPCK280/2..			2	120	27	223	18	59,5	3	-	65	80
SPCK280/3..	280	289,6	3	120	27	223	25	85	3	-	65	80
SPCK280/4..			4	130	27	223	25	111	3	-	65	80
SPCK280/5..			5	130	27	223	25	136	3	-	65	80
SPCK300/1..			1	120	27	243	20	34	3	-	65	80
SPCK300/2..			2	120	27	243	20	59,5	3	-	65	80
SPCK300/3..	300	309,6	3	120	27	243	25	85	3	-	65	80
SPCK300/4..			4	130	27	243	25	111	3	-	65	80
SPCK300/5..			5	130	27	243	25	136	3	-	65	80
SPCK315/1..			1	130	27	258	20	34	4	-	65	80
SPCK315/2..			2	130	27	258	20	59,5	4	-	65	80
SPCK315/3..	315	324,6	3	130	27	258	25	85	4	-	65	80
SPCK315/4..			4	130	27	258	25	111	4	-	65	80
SPCK315/5..			5	130	27	258	25	136	4	-	65	80
SPCK355/1..			1	130	27	298	25	34	4	-	65	80
SPCK355/2..			2	130	27	298	25	59,5	4	-	65	80
SPCK355/3..	355	364,6	3	130	27	298	25	85	4	-	65	80
SPCK355/4..			4	130	27	298	25	111	4	-	65	80
SPCK355/5..			5	130	27	298	25	136	4	-	65	80
SPCK380/1..			1	130	27	323	25	34	4	-	65	80
SPCK380/2..			2	130	27	323	25	59,5	4	-	65	80
SPCK380/3..	380	389,6	3	130	27	323	25	85	4	-	65	80
SPCK380/4..			4	130	27	323	25	111	4	-	65	80
SPCK380/5..			5	130	27	323	25	136	4	-	65	80
SPCK400/1..			1	130	27	343	25	34	4	-	65	80
SPCK400/2..			2	130	27	343	25	59,5	4	-	65	80
SPCK400/3..	400	409,6	3	130	27	343	25	85	4	-	65	80
SPCK400/4..			4	130	27	343	25	111	4	-	65	80
SPCK400/5..			5	130	27	343	25	136	4	-	65	80
SPCK425/1..			1	130	27	368	25	34	4	-	65	80
SPCK425/2..			2	130	27	368	25	59,5	4	-	65	80
SPCK425/3..	425	434,6	3	130	27	368	25	85	4	-	65	80
SPCK425/4..			4	130	27	368	25	111	4	-	65	80
SPCK425/5..			5	130	27	368	25	136	4	-	65	80
SPCK450/1..			1	130	27	393	25	34	4	-	65	80
SPCK450/2..			2	130	27	393	25	59,5	4	-	65	80
SPCK450/3..	450	459,6	3	130	27	393	25	85	4	-	65	80
SPCK450/4..			4	130	27	393	25	111	4	-	65	80
SPCK450/5..			5	130	27	393	25	136	4	-	65	80
SPCK500/1..			1	130	27	443	25	34	4	-	65	80
SPCK500/2..			2	130	27	443	25	59,5	4	-	65	80
SPCK500/3..	500	509,6	3	130	27	443	25	85	4	-	65	80
SPCK500/4..			4	130	27	443	25	111	4	-	65	80
SPCK500/5..			5	130	27	443	25	136	4	-	65	80

Z = Anzahl der Rillen
 * Ausführung in Stahl
 .. = Durchmesser der Bohrung des Keilriemenscheibe (Gehäuse für Spannsatz)

sedis 

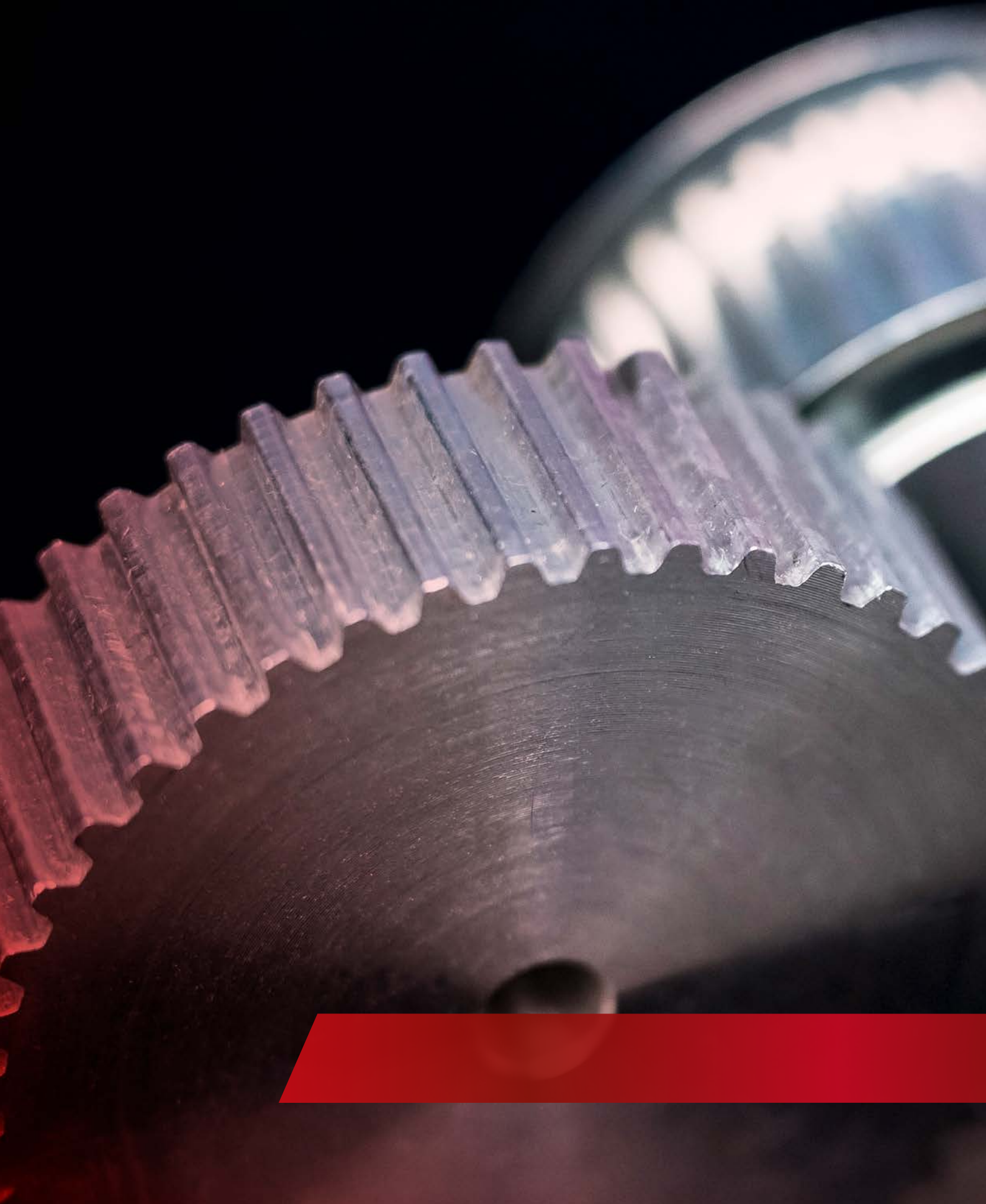



ZAHNRIEMENSCHLEIBEN

ZAHNRIEMENSCHEBEN VOLLNABEN T2,5 / T5

T2,5 - TEILUNG: 2,5 mm
T5 - Teilung: 5 mm
MATERIAL: Aluminium
6082T6 UNI 9006/4



Zahnriemenscheiben für
Riemen mit metrischer Teilung

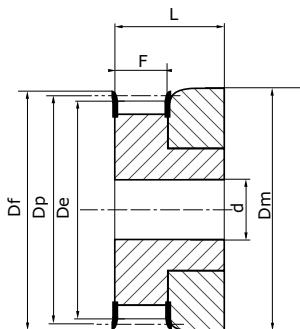

Typ 1

Vollscheibe mit Bordscheiben

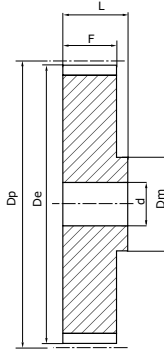

Typ 2

Vollscheibe

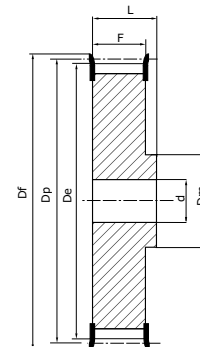

Typ 2F

Vollscheibe mit Bordscheiben

							T2,5 für 6 mm-Riemen				
Art. Nr.	Z	Dp	De	Df	Flansch	Dm	L	F	d	Typ	Kg
16 T2,5 12 F MP	12	9,60	9,00	13	F01	13	16	9	4	1F	0,004
16 T2,5 14 F MP	14	11,20	10,60	15	F02	15	16	9	4	1F	0,006
16 T2,5 15 F MP	15	12,00	11,40	15	F02	15	16	9	4	1F	0,006
16 T2,5 16 F MP	16	12,80	12,20	16	F03	16	16	9	4	1F	0,006
16 T2,5 18 F MP	18	14,40	13,80	17,5	F04	10	16	10	4	1F	0,006
16 T2,5 19 F MP	19	15,20	14,60	18	F05	10	16	10	4	2F	0,007
16 T2,5 20 F MP	20	16,00	15,40	20	F06	11	16	10	4	2F	0,008
16 T2,5 22 F MP	22	17,60	17,00	23	F07	11	16	10	4	2F	0,010
16 T2,5 24 F MP	24	19,15	18,55	23	F07	12	16	10	4	2F	0,012
16 T2,5 25 F MP	25	19,95	19,35	23	F07	13	16	10	4	2F	0,013
16 T2,5 26 F MP	26	20,75	20,15	25	F09	14	16	10	4	2F	0,015
16 T2,5 28 F MP	28	22,35	21,75	25	F09	14	16	10	4	2F	0,016
16 T2,5 30 F MP	30	23,95	23,35	28	F09	16	16	10	6	2F	0,018
16 T2,5 32 F MP	32	25,95	24,95	32	F10	16	16	10	6	2F	0,020
16 T2,5 36 F MP	36	28,75	28,10	36	F12	20	16	10	6	2F	0,026
16 T2,5 40 F MP	40	31,90	31,30	38	F14	22	16	10	6	2F	0,032
16 T2,5 44 MP	44	35,10	34,50	-	-	24	16	10	6	2	0,038
16 T2,5 48 MP	48	38,30	37,70	-	-	26	16	10	6	2	0,048
16 T2,5 60 MP	60	47,85	47,25	-	-	34	16	10	8	2	0,073

							1 T5 für 10 mm-Riemen (F=15)				27 T5 für 16 mm-Riemen (F=21)				36 T5 für 25 mm-Riemen (F=30)			
Art. Nr.	Z	Dp	De	Df	Flansch	Dm	L	d	Typ	Kg	L	d	Typ	Kg	L	d	Typ	Kg
.. T5 10 FMP	10	16,05	15,05	20	F06	8	21	4	2F	0,012	27	4	2F	0,016	36	4	2F	0,023
.. T5 12 FMP	12	19,25	18,25	23	F07	11	21	4	2F	0,016	27	4	2F	0,022	36	4	2F	0,031
.. T5 14 FMP	14	22,45	21,45	25	F08	13	21	4	2F	0,019	27	4	2F	0,026	36	4	2F	0,037
.. T5 15 FMP	15	24,05	23,05	28	F09	16	21	6	2F	0,021	27	6	2F	0,029	36	6	2F	0,041
.. T5 16 FMP	16	25,06	24,60	32	F10	18	21	6	2F	0,025	27	6	2F	0,035	36	6	2F	0,050
.. T5 18 FMP	18	28,80	27,80	32	F10	20	21	6	2F	0,031	27	6	2F	0,043	36	6	2F	0,061
.. T5 19 FMP	19	30,40	29,40	36	F12	22	21	6	2F	0,036	27	6	2F	0,049	36	6	2F	0,070
.. T5 20 FMP	20	32,00	31,00	36	F12	23	21	6	2F	0,038	27	6	2F	0,053	36	6	2F	0,076
.. T5 22 FMP	22	35,15	34,15	38	F14	24	21	6	2F	0,054	27	6	2F	0,062	36	6	2F	0,092
.. T5 24 FMP	24	38,40	37,40	42	F15	26	21	6	2F	0,056	27	6	2F	0,076	36	6	2F	0,109
.. T5 25 FMP	25	39,95	38,95	44	F17	26	21	6	2F	0,058	27	6	2F	0,081	36	6	2F	0,116
.. T5 26 FMP	26	41,60	40,60	44	F17	26	21	6	2F	0,064	27	6	2F	0,085	36	6	2F	0,121
.. T5 27 FMP	27	43,20	42,20	48	F18	30	21	8	2F	0,070	27	8	2F	0,090	36	8	2F	0,128
.. T5 28 FMP	28	44,75	43,75	48	F18	32	21	8	2F	0,075	27	8	2F	0,095	36	8	2F	0,142
.. T5 30 FMP	30	47,95	46,95	51	F19	34	21	8	2F	0,081	27	8	2F	0,105	36	8	2F	0,150
.. T5 32 FMP	32	51,10	50,10	54	F20	38	21	8	2F	0,088	27	8	2F	0,123	36	8	2F	0,176
.. T5 36 FMP	36	57,45	56,45	64	F24	38	21	8	2F	0,114	27	8	2F	0,160	36	8	2F	0,230
.. T5 40 FMP	40	63,85	62,85	66	F25	40	21	8	2F	0,138	27	8	2F	0,193	36	8	2F	0,276
.. T5 42 FMP	42	67,00	66,00	70	F26	40	21	8	2F	0,165	27	8	2F	0,245	36	8	2F	0,352
.. T5 44 MP	44	70,20	69,20	-	-	45	21	8	2	2,000	27	8	2	0,280	36	8	2	0,400
.. T5 48 MP	48	76,55	75,55	-	-	50	21	8	2	0,307	27	8	2	0,430	36	8	2	0,614
.. T5 60 MP	60	95,65	94,65	-	-	65	21	8	2	0,480	27	8	2	0,676	36	8	2	0,966

.. Typ Riemenscheibe



ZAHNRIEMENSCHLEIBEN VOLLNABEN T10

TEILUNG: 10 mm
MATERIAL: Aluminium
6082T6 UNI 9006/4



Zahnriemenscheiben f#r
Riemen mit metrischer Teilung

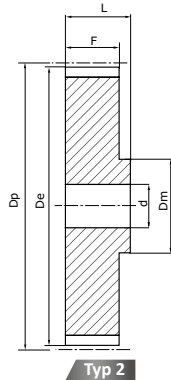

Typ 2
Vollscheibe

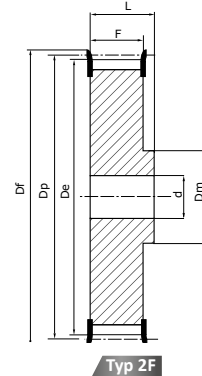

Typ 2F
Vollscheibe mit Bordscheiben

Art. Nr.	Z	Dp	De	Df	Flansch	Dm	31 T10 f#r 16 mm-Riemen (F=21)				40 T10 f#r 25 mm-Riemen (F=30)			
							L	d	Typ	Kg	L	d	Typ	Kg
.. T10 12 FMP	12	38,35	36,35	42	F15	28	31	6	2F	0,076	40	6	2F	0,099
.. T10 14 FMP	14	44,70	42,70	48	F18	32	31	8	2F	0,104	40	8	2F	0,134
.. T10 15 FMP	15	47,90	45,90	51	F19	32	31	8	2F	0,116	40	8	2F	0,152
.. T10 16 FMP	16	51,10	49,10	54	F20	35	31	8	2F	0,134	40	8	2F	0,176
.. T10 18 FMP	18	57,45	55,45	60	F22	40	31	8	2F	0,167	40	8	2F	0,224
.. T10 19 FMP	19	60,65	58,65	66	F25	44	31	8	2F	0,184	40	8	2F	0,247
.. T10 20 FMP	20	63,80	61,80	66	F25	46	31	8	2F	0,208	40	8	2F	0,276
.. T10 22 FMP	22	70,20	68,20	75	F27	52	31	8	2F	0,240	40	8	2F	0,310
.. T10 24 FMP	24	76,55	74,55	83	F29	58	31	8	2F	0,288	40	8	2F	0,392
.. T10 25 FMP	25	79,75	77,70	83	F29	60	31	8	2F	0,295	40	8	2F	0,422
.. T10 26 FMP	26	82,90	80,90	87	F30	60	31	8	2F	0,310	40	8	2F	0,480
.. T10 27 FMP	27	86,10	84,10	91	F31	60	31	8	2F	0,364	40	8	2F	0,536
.. T10 28 FMP	28	89,25	87,25	93	F32	60	31	8	2F	0,441	40	8	2F	0,590
.. T10 30 FMP	30	95,65	93,65	97	F33	60	31	8	2F	0,493	40	8	2F	0,640
.. T10 32 FMP	32	102,00	100,00	106	F35	65	31	10	2F	0,623	40	10	2F	0,693
.. T10 36 FMP	36	114,75	112,75	120	F38	70	31	10	2F	0,767	40	10	2F	0,873
.. T10 40 FMP	40	127,45	125,45	131	F41	80	31	10	2F	0,950	40	10	2F	1,067
.. T10 44 MP	44	140,20	138,20	-	-	88	31	10	2	1,090	40	10	2	1,310
.. T10 48 MP	48	152,95	150,95	-	-	95	31	16	2	1,704	40	16	2	1,516
.. T10 60 MP	60	191,10	189,10	-	-	110	31	16	2	1,704	40	16	2	2,339

.. Typ Riemenscheibe

Art. Nr.	Z	Dp	De	Df	Flansch	Dm	47 T10 f#r 32 mm-Riemen (F=37)				66 T10 f#r 50 mm-Riemen (F=56)			
							L	d	Typ	Kg	L	d	Typ	Kg
.. T10 18 FMP	18	57,45	55,45	60	F22	40	47	10	2F	0,253	66	10	2F	0,422
.. T10 19 FMP	19	60,65	58,65	66	F25	44	47	10	2F	0,286	66	10	2F	0,466
.. T10 20 FMP	20	63,80	61,80	66	F25	46	47	12	2F	0,322	66	12	2F	0,520
.. T10 22 FMP	22	70,20	68,20	75	F27	52	47	12	2F	0,393	66	12	2F	0,640
.. T10 24 FMP	24	76,55	74,55	83	F29	58	47	12	2F	0,475	66	12	2F	0,736
.. T10 25 FMP	25	79,75	77,70	83	F29	60	47	12	2F	0,527	66	12	2F	0,766
.. T10 26 FMP	26	82,90	80,90	87	F30	60	47	12	2F	0,564	66	12	2F	0,845
.. T10 27 FMP	27	86,10	84,10	91	F31	60	47	12	2F	0,602	66	12	2F	0,946
.. T10 28 FMP	28	89,25	87,25	93	F32	60	47	12	2F	0,642	66	12	2F	0,110
.. T10 30 FMP	30	95,65	93,65	97	F33	60	47	12	2F	0,740	66	12	2F	1,169
.. T10 32 FMP	32	102,00	100,00	106	F35	65	47	12	2F	0,844	66	12	2F	1,300
.. T10 36 FMP	36	114,75	112,75	120	F38	70	47	16	2F	1,063	66	16	2F	1,637
.. T10 40 FMP	40	127,45	125,45	131	F41	80	47	16	2F	1,371	66	16	2F	1,999
.. T10 44 MP	44	140,20	138,20	-	-	88	47	16	2	1,611	66	16	2	2,420
.. T10 48 MP	48	152,95	150,95	-	-	95	47	16	2	1,913	66	16	2	2,830
.. T10 60 MP	60	191,10	189,10	-	-	110	47	16	2	3,004	66	16	2	4,366

.. Typ Riemenscheibe



ZAHNRIEMENSCHLEIBE VOLLNABEN ST5 RIEMEN „AT“

TEILUNG: 5 mm
MATERIAL: Aluminium
6082T6 UNI 9006/4



Zahnriemenscheiben für
Riemen mit metrischer Teilung

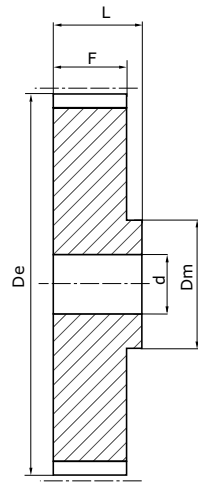

Typ 2
Vollscheibe

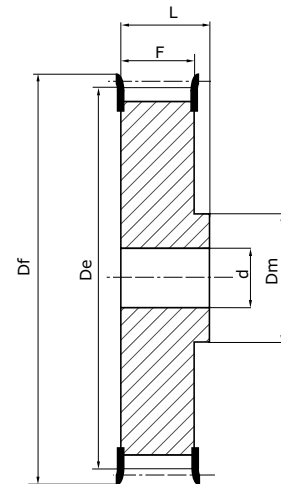

Typ 2F
Vollscheibe mit Bordscheiben

Art. Nr.	Z	De	Df	Flansch	Dm	21 ST5 für 10 mm-Riemen (F=15)				27 ST5 für 16 mm-Riemen (F=21)				36 ST5 für 25 mm-Riemen (F=30)			
						L	d	Typ	Kg	L	d	Typ	Kg	L	d	Typ	Kg
.. ST5 12 FMP	12	17,85	23	F07	11	21	4	2F	0,018	27	4	2F	0,022	36	4	2F	0,031
.. ST5 14 FMP	14	21,05	25	F08	14	21	4	2F	0,019	27	4	2F	0,026	36	4	2F	0,037
.. ST5 15 FMP	15	22,65	28	F09	16	21	6	2F	0,021	27	6	2F	0,029	36	6	2F	0,041
.. ST5 16 FMP	16	24,20	32	F10	18	21	6	2F	0,025	27	6	2F	0,035	36	6	2F	0,050
.. ST5 18 FMP	18	27,40	32	F10	20	21	6	2F	0,031	27	6	2F	0,043	36	6	2F	0,060
.. ST5 19 FMP	19	29,00	36	F12	22	21	6	2F	0,036	27	6	2F	0,049	36	6	2F	0,070
.. ST5 20 FMP	20	30,60	36	F12	23	21	6	2F	0,038	27	6	2F	0,053	36	6	2F	0,076
.. ST5 22 FMP	22	33,85	38	F14	24	21	6	2F	0,048	27	6	2F	0,054	36	6	2F	0,080
.. ST5 24 FMP	24	37,00	42	F15	26	21	6	2F	0,054	27	6	2F	0,076	36	8	2F	0,109
.. ST5 25 FMP	25	38,60	44	F17	26	21	6	2F	0,058	27	6	2F	0,081	36	8	2F	0,118
.. ST5 26 FMP	26	40,20	44	F17	26	21	6	2F	0,062	27	6	2F	0,085	36	8	2F	0,120
.. ST5 27 FMP	27	41,80	48	F18	30	21	8	2F	0,064	27	8	2F	0,090	36	8	2F	0,128
.. ST5 28 FMP	28	43,35	48	F18	32	21	8	2F	0,071	27	8	2F	0,092	36	8	2F	0,135
.. ST5 30 FMP	30	46,55	51	F19	34	21	8	2F	0,076	27	8	2F	0,105	36	8	2F	0,150
.. ST5 32 FMP	32	49,70	54	F20	36	21	8	2F	0,088	27	8	2F	0,123	36	8	2F	0,178
.. ST5 36 FMP	36	56,05	64	F24	38	21	8	2F	0,114	27	8	2F	0,160	36	8	2F	0,230
.. ST5 40 FMP	40	62,45	66	F25	40	21	8	2F	0,138	27	8	2F	0,193	36	8	2F	0,278
.. ST5 42 FMP	42	65,60	70	F26	40	21	8	2F	0,180	27	8	2F	0,205	36	8	2F	0,284
.. ST5 44 MP	44	68,80	-	-	45	21	8	2	0,185	27	8	2	0,228	36	8	2	0,315
.. ST5 48 MP	48	75,15	-	-	50	21	8	2	0,200	27	8	2	0,280	36	8	2	0,400
.. ST5 60 MP	60	94,25	-	-	65	21	8	2	0,307	27	8	2	0,430	36	8	2	0,614

.. Typ Riemenscheibe



ZAHNRIEMENSCHLEIBE VOLLNABEN ST10 RIEMEN „AT“

TEILUNG: 10 mm
MATERIAL: Aluminium
6082T6 UNI 9006/4



Zahnriemenscheiben f#r Riemen
„AT“ mit metrischer Teilung

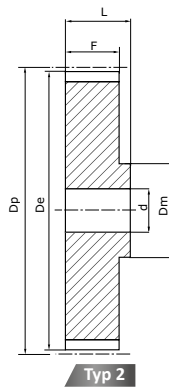

Typ 2
Vollscheibe

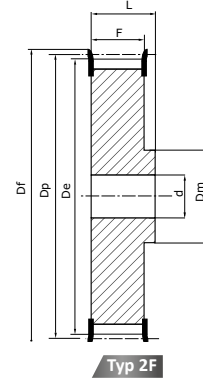

Typ 2F
Vollscheibe mit Bordscheiben

Art. Nr.	Z	De	Df	Flansch	Dm	31 ST10 f#r 16 mm-Riemen (F=21)				40 ST10 f#r 25 mm-Riemen (F=30)			
						L	d	Typ	Kg	L	d	Typ	Kg
.. ST10 15 FMP	15	45,90	51	F19	31	31	8	2F	0,118	40	8	2F	0,152
.. ST10 16 FMP	16	49,05	54	F20	35	31	8	2F	0,134	40	8	2F	0,176
.. ST10 18 FMP	18	55,45	60	F22	40	31	8	2F	0,167	40	8	2F	0,253
.. ST10 19 FMP	19	58,65	66	F25	44	31	8	2F	0,184	40	8	2F	0,286
.. ST10 20 FMP	20	61,80	66	F25	46	31	8	2F	0,208	40	8	2F	0,322
.. ST10 22 FMP	22	68,15	75	F27	52	31	8	2F	0,253	40	8	2F	0,393
.. ST10 24 FMP	24	74,55	83	F29	58	31	8	2F	0,288	40	8	2F	0,475
.. ST10 25 FMP	25	77,75	83	F29	60	31	8	2F	0,310	40	8	2F	0,527
.. ST10 26 FMP	26	80,90	87	F30	60	31	8	2F	0,357	40	8	2F	0,564
.. ST10 27 FMP	27	84,10	91	F31	60	31	8	2F	0,364	40	8	2F	0,602
.. ST10 28 FMP	28	87,25	93	F32	60	31	8	2F	0,401	40	8	2F	0,642
.. ST10 30 FMP	30	93,65	97	F33	60	31	8	2F	0,441	40	8	2F	0,74
.. ST10 32 FMP	32	100,00	106	F35	65	31	10	2F	0,493	40	10	2F	0,844
.. ST10 36 FMP	36	112,75	120	F38	70	31	10	2F	0,623	40	10	2F	1,063
.. ST10 40 FMP	40	125,45	135	F42	80	31	10	2F	0,787	40	10	2F	1,371
.. ST10 44 MP	44	138,20	-	-	88	31	10	2	0,993	40	10	2	1,611
.. ST10 48 MP	48	150,95	-	-	95	31	16	2	1,090	40	16	2	1,611
.. ST10 60 MP	60	189,10	-	-	110	31	16	2	1,701	40	16	2	3,004

.. Typ Riemenscheibe

Art. Nr.	Z	De	Df	Flansch	Dm	47 ST10 f#r 32 mm-Riemen (F=37)				66 ST10 f#r 50 mm-Riemen (F=56)			
						L	d	Typ	Kg	L	d	Typ	Kg
.. ST10 18 FMP	18	55,45	60	F22	40	47	10	2F	0,253	66	10	2F	0,422
.. ST10 19 FMP	19	58,65	66	F25	44	47	10	2F	0,286	66	10	2F	0,466
.. ST10 20 FMP	20	61,80	66	F25	46	47	12	2F	0,322	66	12	2F	0,520
.. ST10 22 FMP	22	68,15	75	F27	52	47	12	2F	0,393	66	12	2F	0,640
.. ST10 24 FMP	24	74,55	83	F29	58	47	12	2F	0,475	66	12	2F	0,736
.. ST10 25 FMP	25	77,75	83	F29	60	47	12	2F	0,527	66	12	2F	0,766
.. ST10 26 FMP	26	80,90	87	F30	60	47	12	2F	0,564	66	12	2F	0,845
.. ST10 27 FMP	27	84,10	91	F31	60	47	12	2F	0,602	66	12	2F	0,946
.. ST10 28 FMP	28	87,25	93	F32	60	47	12	2F	0,642	66	12	2F	0,110
.. ST10 30 FMP	30	93,65	97	F33	60	47	12	2F	0,740	66	12	2F	1,169
.. ST10 32 FMP	32	100,00	106	F35	65	47	12	2F	0,844	66	12	2F	1,300
.. ST10 36 FMP	36	112,75	120	F38	70	47	12	2F	1,063	66	16	2F	1,637
.. ST10 40 FMP	40	125,45	135	F42	80	47	16	2F	1,371	66	16	2F	1,999
.. ST10 44 MP	44	138,20	-	-	88	47	16	2	1,611	66	16	2	2,420
.. ST10 48 MP	48	150,95	-	-	95	47	16	2	1,913	66	16	2	2,830
.. ST10 60 MP	60	189,10	-	-	110	47	16	2	3,004	66	16	2	4,366

.. Typ Riemenscheibe

ZAHNRIEMENSCHLEIBEN VOLLNABEN XL 037

TEILUNG: 5,08 X 7,75 mm

MATERIAL:

Stahl C40 UNI 7845

Aluminium 6082T6 UNI

9006/4



Zahnriemenscheiben, Teilung
in Inch

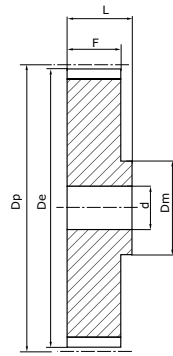

Typ 2
Vollscheibe

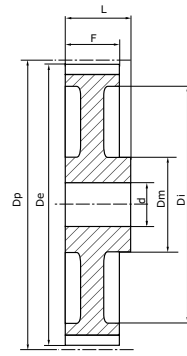

Type 2A
leichtere Riemenscheibe

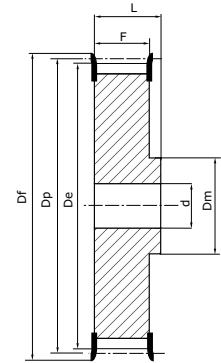

Typ 2F
Vollscheibe mit Bordscheiben

XL 037 für 9,525-Riemem

Art. Nr.	Z	Dp	De	Df	Flansch	Dm	Di	F	L	d	Typ	Kg
10 XL037.. F	10	16,17	15,66	23	F07	9,5	-	14,3	20	4	2F	0,02
11 XL037 .. F	11	17,79	17,28	23	F07	9,5	-	14,3	20	4	2F	0,02
12 XL037 .. F	12	19,40	18,90	25	F08	10	-	14,3	20	4	2F	0,03
13 XL037 .. F	13	21,02	20,51	28	F09	10	-	14,3	20	4	2F	0,04
14 XL037 .. F	14	22,64	22,13	28	F09	15	-	14,3	20	4	2F	0,05
15 XL037 .. F	15	24,26	23,75	28	F09	15	-	14,3	20	6	2F	0,05
16 XL037 .. F	16	25,87	25,36	32	F10	16	-	14,3	20	6	2F	0,06
17 XL037 .. F	17	27,49	26,98	35	F11	20	-	14,3	20	6	2F	0,07
18 XL037 .. F	18	29,11	28,60	35	F11	20	-	14,3	20	6	2F	0,08
19 XL037 .. F	19	30,72	30,22	38	F13	20	-	14,3	22	6	2F	0,09
20 XL037 .. F	20	33,34	31,83	38	F13	23,5	-	14,3	22	6	2F	0,11
21 XL037 .. F	21	33,96	33,45	38	F13	23,5	-	14,3	22	6	2F	0,12
22 XL037 .. F	22	35,57	35,07	41	F14	25	-	14,3	22	6	2F	0,13
24 XL037 .. F	24	38,81	38,30	44	F16	30	-	14,3	22	6	2F	0,15
26 XL037 .. F	26	42,04	41,53	48	F17	30	-	14,3	22	8	2F	0,19
27 XL037 .. F	27	43,66	43,15	48	F17	34	-	14,3	22	8	2F	0,20
28 XL037 .. F	28	45,28	44,77	51	F19	34	-	14,3	22	8	2F	0,22
29 XL037 .. F	29	46,89	46,39	51	F19	34	-	14,3	22	8	2F	0,22
30 XL037 .. F	30	48,51	48,00	54	F20	38	-	14,3	22	8	2F	0,11
32 XL037 .. F	32	51,74	51,24	57	F22	38	-	14,3	25	8	2F	0,12
34 XL037 ..	34	54,98	54,47	-	-	45	-	14,3	25	8	2	0,12
35 XL037 ..	35	56,60	56,09	-	-	45	-	14,3	25	8	2	0,13
36 XL037 ..	36	58,21	57,70	-	-	45	-	14,3	25	8	2	0,14
38 XL037 ..	38	61,45	60,94	-	-	45	-	14,3	25	8	2	0,16
39 XL037 ..	39	63,06	62,56	-	-	45	-	14,3	25	8	2	0,17
40 XL037 ..	40	64,68	64,17	-	-	45	-	14,3	25	8	2	0,17
41 XL037 ..	41	66,30	65,79	-	-	45	-	14,3	25	8	2	0,18
42 XL037 ..	42	67,91	67,41	-	-	45	-	14,3	25	8	2	0,18
43 XL037 ..	43	69,53	69,02	-	-	45	-	14,3	25	8	2	0,19
44 XL037 ..	44	71,15	70,64	-	-	45	-	14,3	25	8	2	0,19
45 XL037 ..	45	72,77	72,26	-	-	45	61	14,3	25	10	2A	0,19
47 XL037 ..	47	76,00	75,49	-	-	45	61	14,3	25	10	2A	0,19
48 XL037 ..	48	77,62	77,11	-	-	45	61	14,3	25	10	2A	0,19
49 XL037 ..	49	79,23	78,73	-	-	45	61	14,3	25	10	2A	0,22
52 XL037 ..	52	84,08	83,58	-	-	45	67	14,3	25	10	2A	0,22
56 XL037 ..	56	90,55	90,04	-	-	45	80	14,3	25	10	2A	0,25
57 XL037 ..	57	92,17	91,66	-	-	45	80	14,3	25	10	2A	0,25
58 XL037 ..	58	93,79	93,28	-	-	45	80	14,3	25	10	2A	0,25
60 XL037 ..	60	97,02	96,51	-	-	45	80	14,3	25	10	2A	0,25
70 XL037 ..	70	113,19	112,68	-	-	45	100	14,3	25	10	2A	0,30
72 XL037 ..	72	116,42	115,92	-	-	45	100	14,3	25	10	2A	0,30

.. Hinzufügung von AL für eine Alu-Riemenscheibe



ZAHNRIEMENSCHLEIBEN VOLLNABEN L050 / L075 / L100

TEILUNG: 3/8" (9,525 mm)
 MATERIAL:
 Stahl C40 UNI 7845
 Guss EN-GJL-250 UNI EN 1561

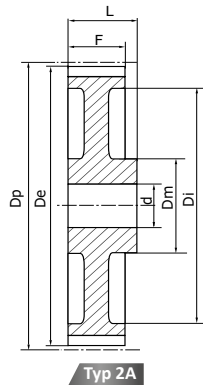
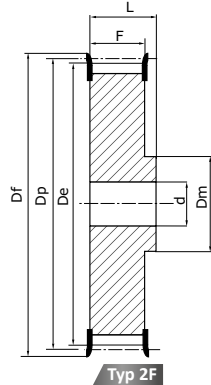
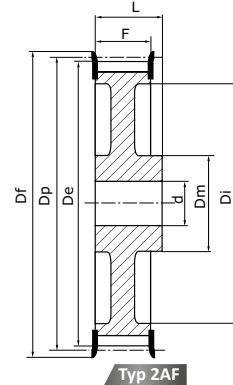
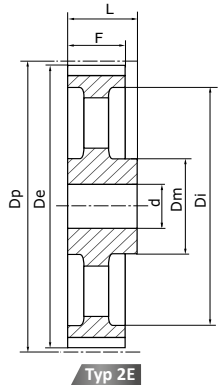
 Typ 2A
 leichtere Riemenscheibe

 Typ 2F
 Vollscheibe mit Bordscheiben

 Typ 2AF
 leichtere Riemenscheibe

 Typ 2E
 Hohl-Riemenscheibe

Stahl = Z10 bis Z48
 Guss = Z49 bis Z120

Art. Nr.	Z	Dp	De	Df	Flansch	Dm	Di	L050 für 12,7-Riemen					L075 für 19,05-Riemen					L100 für 25,4-Riemen				
								F	L	d	Typ	Kg	F	L	d	Typ	Kg	F	L	d	Typ	Kg
10 L .. FMP	10	30,32	29,56	37	F13	20	-	19	28	8	2F	0,11	25,4	38	8	2F	0,15	31,8	45	8	2F	0,15
11 L .. FMP	11	33,35	32,59	37	F13	22	-	19	30	8	2F	0,14	25,4	38	8	2F	0,17	31,8	45	8	2F	0,20
12 L .. FMP	12	36,38	35,62	43	F16	24	-	19	30	8	2F	0,17	25,4	38	8	2F	0,22	31,8	45	8	2F	0,26
13 L .. FMP	13	39,41	38,65	44	F17	28	-	19	30	8	2F	0,18	25,4	38	8	2F	0,25	31,8	45	8	2F	0,30
14 L .. FMP	14	42,45	41,68	48	F18	28	-	19	30	8	2F	0,22	25,4	38	11	2F	0,28	31,8	45	11	2F	0,34
15 L .. FMP	15	45,48	44,72	51	F19	34	-	19	30	8	2F	0,28	25,4	38	11	2F	0,38	31,8	45	11	2F	0,45
16 L .. FMP	16	48,51	47,75	54	F20	36	-	19	32	8	2F	0,35	25,4	38	11	2F	0,43	31,8	45	11	2F	0,52
17 L .. FMP	17	51,54	50,78	57	F21	36	-	19	32	10	2F	0,36	25,4	38	11	2F	0,44	31,8	45	11	2F	0,53
18 L .. FMP	18	54,57	53,81	60	F22	40	-	19	32	10	2F	0,42	25,4	38	11	2F	0,52	31,8	45	11	2F	0,62
19 L .. FMP	19	57,61	56,84	64	F24	40	-	19	32	10	2F	0,45	25,4	38	11	2F	0,56	31,8	45	11	2F	0,66
20 L .. FMP	20	60,64	59,88	66	F25	40	-	19	32	10	2F	0,48	25,4	38	11	2F	0,59	31,8	45	11	2F	0,72
21 L .. FMP	21	63,67	62,91	70	F26	45	-	19	32	10	2F	0,57	25,4	38	11	2F	0,64	31,8	45	11	2F	0,77
22 L .. FMP	22	66,70	65,94	75	F27	45	-	19	32	10	2F	0,59	25,4	38	11	2F	0,69	31,8	45	11	2F	0,88
23 L .. FMP	23	69,73	68,97	79	F28	55	-	19	32	10	2F	0,61	25,4	38	11	2F	0,76	31,8	45	11	2F	1,12
24 L .. FMP	24	72,77	72,00	79	F28	55	-	19	32	10	2F	0,80	25,4	38	11	2F	0,87	31,8	45	11	2F	1,13
25 L .. FMP	25	75,80	75,04	83	F29	58	-	19	32	10	2F	0,85	25,4	38	11	2F	0,95	31,8	45	11	2F	1,18
26 L .. FMP	26	78,83	78,07	87	F30	58	-	19	32	11	2F	0,90	25,4	38	11	2F	1,06	31,8	45	11	2F	1,24
27 L .. FMP	27	81,86	81,10	87	F30	58	-	19	32	11	2F	0,91	25,4	38	11	2F	1,18	31,8	45	11	2F	1,35
28 L .. FMP	28	84,89	84,13	91	F31	58	-	19	32	11	2F	0,96	25,4	38	11	2F	1,19	31,8	45	11	2F	1,42
29 L .. FMP	29	87,93	87,16	93	F32	58	-	19	32	11	2F	1,00	25,4	38	11	2F	1,25	31,8	45	11	2F	1,50
30 L .. FMP	30	90,96	90,20	97	F33	70	-	19	32	11	2F	1,07	25,4	38	11	2F	1,33	31,8	45	11	2F	1,61
32 L .. FMP	32	97,02	96,26	102	F34	70	-	19	32	11	2F	1,23	25,4	38	11	2F	1,54	31,8	45	11	2F	1,84
33 L .. FMP	33	100,05	99,29	106	F35	70	-	19	32	11	2F	1,30	25,4	38	11	2F	1,63	31,8	45	11	2F	1,95
34 L .. FMP	34	103,08	102,32	112	F35	70	-	19	32	11	2F	1,37	25,4	38	11	2F	1,67	31,8	45	11	2F	2,10
35 L .. FMP	35	106,12	105,35	112	F36	70	-	19	32	11	2F	1,44	25,4	38	11	2F	1,80	31,8	45	11	2F	2,23
36 L .. FMP	36	109,15	108,39	115	F37	70	-	19	32	11	2F	1,50	25,4	38	11	2F	1,89	31,8	45	11	2F	2,32
40 L .. FMP	40	121,28	120,51	128	F40	70	100	19	32	11	2AF	1,77	25,4	38	11	2A	2,35	31,8	45	11	2AF	2,80
41 L .. FMP	41	124,31	123,55	131	F41	70	103	19	32	11	2AF	1,84	25,4	38	11	2AF	2,40	31,8	45	11	2AF	2,95
42 L .. FMP	42	127,34	126,58	135	F42	70	106	19	32	11	2AF	1,97	25,4	38	11	2AF	2,53	31,8	45	11	2AF	3,10
44 L .. FMP	44	133,40	132,64	142	F45	70	112	19	32	11	2AF	2,20	25,4	38	11	2AF	2,75	31,8	45	11	2AF	3,36
45 L .. FMP	45	136,44	135,67	142	F45	70	115	19	32	11	2AF	2,27	25,4	38	11	2AF	2,86	31,8	45	11	2AF	3,45
47 L .. FMP	47	142,50	141,74	150	F48	70	121	19	32	11	2AF	2,45	25,4	38	11	2AF	3,02	31,8	45	11	2AF	3,65
48 L .. FMP	48	145,53	144,77	150	F48	70	124	19	32	11	2AF	2,67	25,4	38	11	2AF	3,19	31,8	45	11	2AF	3,86
49 L .. MP	49	148,56	147,80	-	-	70	127	19	32	14	2A	1,80	19	38	14	2A	2,10	31,8	45	14	2A	2,40
50 L .. MP	50	151,60	150,83	-	-	70	130	19	32	14	2A	1,90	19	38	14	2A	2,20	31,8	45	14	2A	2,50
52 L .. MP	52	157,66	156,90	-	-	70	136	19	32	14	2A	2,10	19	38	14	2A	2,38	31,8	45	14	2A	2,70
56 L .. MP	56	169,79	169,02	-	-	70	149	19	32	14	2A	2,18	19	38	14	2A	2,49	31,8	45	14	2A	2,91
57 L .. MP	57	172,82	172,06	-	-	70	152	19	32	14	2A	2,47	19	38	14	2A	2,73	31,8	45	14	2A	3,10
60 L .. MP	60	181,91	181,15	-	-	75	160	19	42	14	2A	3,10	19	45	14	2A	3,44	31,8	50	14	2A	3,55
65 L .. MP	65	197,07	196,31	-	-	75	176	19	42	14	2E	3,20	25,4	45	14	2E	3,50	31,8	50	14	2E	4,00
66 L .. MP	66	200,11	199,34	-	-	75	179	19	42	14	2E	3,23	25,4	45	14	2E	3,60	31,8	50	14	2E	4,15
72 L .. MP	72	218,30	217,53	-	-	75	197	19	42	14	2E	4,86	25,4	45	14	2E	4,58	31,8	50	14	2E	5,00
84 L .. MP	84	254,68	253,92	-	-	75	233	19	42	14	2E	5,00	25,4	45	14	2E	5,60	31,8	50	14	2E	6,30
90 L .. MP	90	272,87	272,11	-	-	75	252	19	42	14	2E	5,50	25,4	45	14	2E	6,50	31,8	50	14	2E	7,50
96 L .. MP	96	291,06	290,30	-	-	75	269	19	42	14	2E	6,00	25,4	45	14	2E	7,00	31,8	50	14	2E	8,20
120 L .. MP	120	363,83	363,07	-	-	75	342	19	42	14	2E	8,50	25,4	45	14	2E	10,00	31,8	50	14	2E	11,50

.. Riemenbreite in 1/100 Inch d.h. 050, 075 oder 100

ZAHNRIEMENSCHLEIBEN VOLLNABEN H075 / H100 / H150

TEILUNG: 1/2" (12,7 mm)

MATERIAL:

Stahl C40 UNI 7845

Guss EN-GJL-250 UNI EN 1561

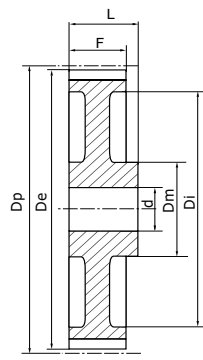
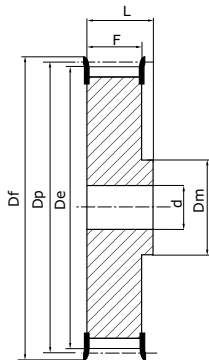
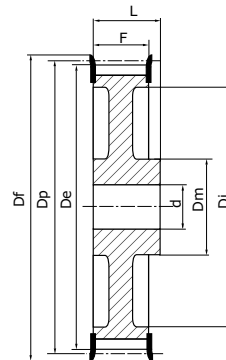
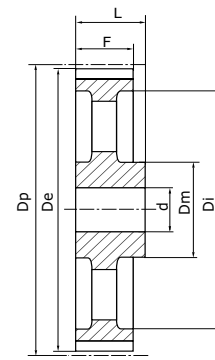
Typ 2A
 leichtere Riemenscheibe

Typ 2F
 Vollscheibe mit Bordscheiben

Typ 2AF
 leichtere Riemenscheibe

Typ 2E
 Hohl-Riemenscheibe

 Stahl = Z14 bis Z42
 Stahl = Z44 bis Z156

Art. Nr.	Z	Dp	De	Df	Flansch	H075 für 19,05-Riemen (F=26,4)					H100 für 25,4-Riemen (F=31,8)					H150 für 38,10-Riemen (F=46)							
						Dm	Di	L	d	Typ	Kg	Dm	Di	L	d	Typ	Kg	Dm	Di	L	d	Typ	Kg
14H .. FMP	14	56,60	55,22	64	F24	40	-	40	8	2F	0,59	45	-	45	11	2F	0,67	42	-	58	11	2F	0,91
15H .. FMP	15	60,64	59,27	66	F25	45	-	40	8	2F	0,65	45	-	45	11	2F	0,77	45	-	58	11	2F	0,99
16H .. FMP	16	64,68	63,31	70	F26	45	-	40	8	2F	0,70	45	-	45	11	2F	0,88	45	-	58	11	2F	1,08
17H .. FMP	17	68,72	67,35	75	F27	45	-	40	8	2F	0,73	45	-	45	11	2F	0,88	45	-	58	11	2F	1,15
18H .. FMP	18	72,77	71,39	79	F28	55	-	40	11	2F	0,91	55	-	45	14	2F	1,06	55	-	58	14	2F	1,45
19H .. FMP	19	76,81	75,44	83	F29	60	-	40	11	2F	1,08	60	-	45	14	2F	1,23	60	-	58	14	2F	1,55
20H .. FMP	20	80,85	79,48	87	F30	62	-	40	11	2F	1,18	62	-	45	14	2F	1,33	62	-	58	14	2F	1,66
21H .. FMP	21	84,89	83,52	91	F31	65	-	40	11	2F	1,30	65	-	45	14	2F	1,43	65	-	58	14	2F	1,87
22H .. FMP	22	88,94	87,56	93	F32	68	-	40	11	2F	1,42	68	-	45	14	2F	1,63	68	-	58	14	2F	2,07
23H .. FMP	23	92,98	91,61	97	F33	72	-	40	11	2F	1,67	72	-	45	14	2F	1,85	72	-	58	14	2F	2,28
24H .. FMP	24	97,02	95,65	102	F34	72	-	40	11	2F	1,71	72	-	45	14	2F	1,93	72	-	58	14	2F	2,50
25H .. FMP	25	101,06	99,69	106	F35	72	-	40	11	2F	1,87	72	-	45	14	2F	2,07	72	-	58	14	2F	2,71
26H .. FMP	26	105,11	103,73	112	F36	80	-	40	11	2F	2,00	80	-	45	14	2F	2,30	80	-	58	14	2F	2,99
27H .. FMP	27	109,15	107,78	115	F37	80	-	40	11	2F	2,10	80	-	45	14	2F	2,40	80	-	58	14	2F	3,15
28H .. FMP	28	113,19	111,82	120	F38	80	-	40	11	2F	2,26	80	-	45	14	2F	2,53	80	-	58	14	2F	3,39
29H .. FMP	29	117,23	115,86	123	F39	80	-	40	11	2F	2,49	80	-	45	14	2F	2,70	80	-	58	14	2F	3,57
30H .. FMP	30	121,28	119,90	128	F40	80	-	40	11	2F	2,70	80	-	45	14	2F	2,93	80	-	58	14	2F	3,86
32H .. FMP	32	129,36	127,99	135	F42	80	-	40	11	2F	2,85	80	-	45	14	2F	3,06	80	-	58	14	2F	4,37
33H .. FMP	33	133,40	132,03	140	F44	80	-	40	11	2F	3,10	80	-	45	14	2F	3,40	80	-	58	14	2F	4,66
34H .. FMP	34	137,45	136,07	142	F45	80	-	40	11	2F	3,30	80	-	45	14	2F	3,57	80	-	58	14	2F	4,98
35H .. FMP	35	141,49	140,12	150	F48	80	-	40	11	2F	3,50	80	-	45	14	2F	3,80	80	-	58	14	2F	5,30
36H .. FMP	36	145,53	144,16	150	F48	80	118	40	11	2AF	3,65	80	118	45	14	2AF	3,92	80	118	58	14	2AF	5,50
38H .. FMP	38	153,62	152,24	158	F50	80	126	40	11	2AF	3,90	80	126	45	14	2AF	4,40	80	126	58	14	2AF	6,10
40H .. FMP	40	161,70	160,33	168	F52	80	134	40	14	2AF	4,23	80	134	45	14	2AF	4,95	80	134	58	14	2AF	6,80
44H .. FMP	44	177,87	176,50	184	F55	80	150	40	14	2AF	5,20	80	150	50	14	2AF	6,20	80	150	58	19	2AF	8,50
45H .. FMP	45	181,91	180,54	192	F57	80	154	40	14	2AF	5,45	80	154	50	14	2AF	6,45	80	154	58	19	2AF	9,00
48H .. FMP	48	194,04	192,67	200	F59	90	166	45	14	2AF	4,30	90	166	50	14	2AF	5,30	90	166	65	19	2AF	6,70
49H .. MP	49	198,08	196,71	-	-	90	170	45	14	2A	4,50	90	170	50	19	2A	5,40	90	170	65	19	2A	7,00
50H .. MP	50	202,13	200,75	-	-	90	174	45	14	2A	4,66	90	174	50	19	2A	5,50	90	174	65	19	2A	7,10
52H .. MP	52	210,21	208,84	-	-	-	-	-	-	-	-	90	182	50	19	2A	5,80	90	182	65	19	2A	7,30
58H .. MP	58	234,47	233,09	-	-	-	-	-	-	-	-	90	207	50	19	2E	6,20	90	207	65	19	2E	8,10
60H .. MP	60	242,55	241,18	-	-	-	-	-	-	-	-	90	215	50	19	2E	7,50	90	215	65	19	2E	9,00
70H .. MP	70	282,98	281,61	-	-	-	-	-	-	-	-	100	255	55	19	2E	8,20	100	255	65	24	2E	10,50
72H .. MP	72	291,06	289,69	-	-	-	-	-	-	-	-	100	263	55	19	2E	9,00	100	263	65	24	2E	11,00
82H .. MP	82	331,49	330,12	-	-	-	-	-	-	-	-	100	304	55	19	2E	9,20	100	304	65	24	2E	12,00
84H .. MP	84	339,57	338,20	-	-	-	-	-	-	-	-	100	312	55	19	2E	10,00	100	312	65	24	2E	13,00
94H .. MP	94	380,00	378,63	-	-	-	-	-	-	-	-	120	352	60	19	2E	13,00	120	352	65	24	2E	16,00
96H .. MP	96	388,08	386,71	-	-	-	-	-	-	-	-	120	360	60	19	2E	13,80	120	360	65	24	2E	17,00
106H .. MP	106	428,51	427,14	-	-	-	-	-	-	-	-	120	401	60	19	2E	15,50	120	401	65	24	2E	19,50
116H .. MP	116	468,93	467,56	-	-	-	-	-	-	-	-	120	441	60	19	2E	18,00	120	441	65	24	2E	22,00
118H .. MP	118	477,02	475,65	-	-	-	-	-	-	-	-	120	449	60	19	2E	20,00	120	449	65	24	2E	23,50
120H .. MP	120	485,10	483,73	-	-	-	-	-	-	-	-	120	458	60	19	2E	22,00	120	458	65	24	2E	25,00
150H .. MP	150	606,38	605,01	-	-	-	-	-	-	-	-	120	579	60	19	2E	25,00	120	579	65	24	2E	31,50
152H .. MP	152	614,47	613,09	-	-	-	-	-	-	-	-	120	587	60	19	2E	26,00	120	587	65	24	2E	33,00

.. Riemenbreite in 1/100 Inch d.h. 050, 075 oder 100



ZAHNRIEMENSCHLEIBEN VOLLNABEN H200 / H300

TEILUNG: 1/2" (12,7 mm)
 MATERIAL:
 Stahl C40 UNI 7845
 Guss EN-GJL-250 UNI EN 1561

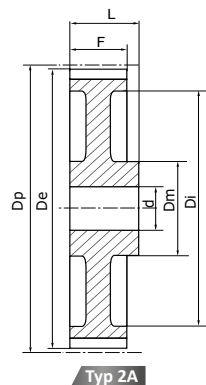
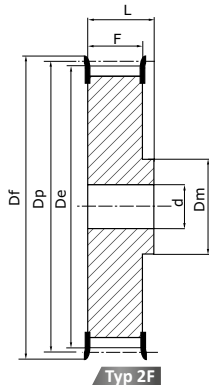
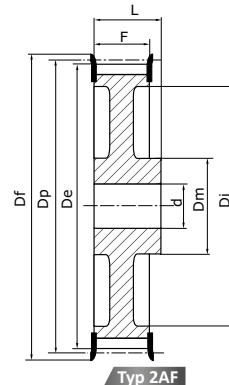
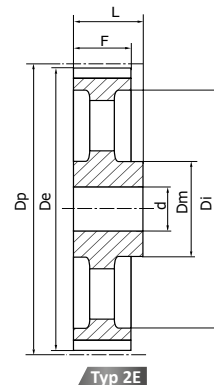
 Typ 2A
 leichtere Riemen-scheibe

 Typ 2F
 Vollscheibe mit Bordscheiben

 Typ 2AF
 leichtere Riemen-scheibe

 Typ 2E
 Hohl-Riemen-scheibe

Stahl = Z14 bis Z42
 Stahl = Z44 bis Z156

							H200 für 50,8-Riemen (F=58,7)				H300 für 76,2-Riemen (F=85,7)				
Art. Nr.	Z	Dp	De	Df	Flansch	Dm	Di	L	d	Typ	Kg	L	d	Typ	Kg
14 H .. FMP	14	56,60	55,22	64	F24	40	-	70	11	2F	1,13	100	11	2F	1,35
15 H .. FMP	15	60,64	59,27	66	F25	45	-	70	11	2F	1,21	100	11	2F	1,55
16 H .. FMP	16	64,68	63,31	70	F26	45	-	70	11	2F	1,30	100	11	2F	1,80
17 H .. FMP	17	68,72	67,35	75	F27	45	-	70	11	2F	1,45	100	11	2F	2,10
18 H .. FMP	18	72,77	71,39	79	F28	55	-	70	14	2F	1,65	100	19	2F	2,38
19 H .. FMP	19	76,81	75,44	83	F29	60	-	70	14	2F	1,90	100	19	2F	2,64
20 H .. FMP	20	80,85	79,48	87	F30	62	-	70	14	2F	2,11	100	19	2F	3,10
21 H .. FMP	21	84,89	83,52	91	F31	65	-	70	14	2F	2,23	100	19	2F	3,32
22 H .. FMP	22	88,94	87,56	93	F32	68	-	70	14	2F	2,45	100	19	2F	3,67
23 H .. FMP	23	92,98	91,61	97	F33	72	-	70	14	2F	2,71	100	19	2F	4,00
24 H .. FMP	24	97,02	95,65	102	F34	72	-	70	14	2F	2,97	100	19	2F	4,40
25 H .. FMP	25	101,06	99,69	106	F35	72	-	70	14	2F	3,32	100	19	2F	4,79
26 H .. FMP	26	105,11	103,73	112	F36	80	-	70	14	2F	3,61	100	19	2F	5,20
27 H .. FMP	27	109,15	107,78	115	F37	80	-	70	14	2F	3,90	100	19	2F	5,60
28 H .. FMP	28	113,19	111,82	120	F38	80	-	70	14	2F	4,10	100	19	2F	5,60
29 H .. FMP	29	117,23	115,86	123	F39	80	-	70	14	2F	4,42	100	19	2F	6,00
30 H .. FMP	30	121,28	119,90	128	F40	80	-	70	14	2F	4,74	100	19	2F	7,00
32 H .. FMP	32	129,36	127,99	135	F42	80	-	70	14	2F	5,60	100	19	2F	7,80
33 H .. FMP	33	133,40	132,03	140	F44	80	-	70	14	2F	5,90	100	19	2F	8,70
34 H .. FMP	34	137,45	136,07	142	F45	80	-	70	14	2F	6,20	100	19	2F	9,70
35 H .. FMP	35	141,49	140,12	150	F48	80	-	70	14	2F	6,60	100	19	2F	9,80
36 H .. FMP	36	145,53	144,16	150	F48	80	118	70	14	2AF	7,10	100	19	2AF	9,90
38 H .. FMP	38	153,62	152,24	158	F50	80	126	70	14	2AF	7,80	100	19	2AF	11,00
40 H .. FMP	40	161,70	160,33	168	F52	80	134	70	14	2AF	8,40	100	19	2AF	12,20
44 H .. FMP	44	177,87	176,50	184	F55	80	150	70	19	2AF	10,50	100	24	2AF	15,00
45 H .. FMP	45	181,91	180,54	192	F57	80	154	70	19	2AF	11,30	100	24	2AF	15,20
48 H .. FMP	48	194,04	192,67	200	F59	90	166	75	24	2AF	8,60	100	24	2AF	11,40
49 H .. MP	49	198,08	196,71	-	-	90	170	75	24	2A	7,60	100	24	2A	9,40
50 H .. MP	50	202,13	200,75	-	-	90	174	75	24	2A	8,30	100	24	2A	10,60
52 H .. MP	52	210,21	208,84	-	-	90	182	75	24	2A	8,50	100	24	2A	11,80
58 H .. MP	58	234,47	233,09	-	-	90	207	75	24	2E	10,00	100	24	2E	12,20
60 H .. MP	60	242,55	241,18	-	-	90	215	75	24	2E	11,00	100	24	2E	13,00
70 H .. MP	70	282,98	281,61	-	-	100	255	75	28	2E	12,50	100	28	2E	16,50
72 H .. MP	72	291,06	289,69	-	-	100	263	75	28	2E	14,00	100	28	2E	19,00
82 H .. MP	82	331,49	330,12	-	-	100	304	75	28	2E	13,50	100	28	2E	18,00
84 H .. MP	84	339,57	338,20	-	-	100	312	75	28	2E	15,00	100	28	2E	20,00
94 H .. MP	94	380,00	378,63	-	-	120	352	75	28	2E	18,90	100	28	2E	25,50
96 H .. MP	96	388,08	386,71	-	-	120	360	75	28	2E	20,30	100	28	2E	27,00
106 H .. MP	106	428,51	427,14	-	-	120	401	75	28	2E	22,50	100	28	2E	27,90
116 H .. MP	116	468,93	467,56	-	-	120	441	75	28	2E	24,70	100	28	2E	28,50
118 H .. MP	118	477,02	475,65	-	-	120	449	75	28	2E	26,00	100	28	2E	31,00
120 H .. MP	120	485,10	483,73	-	-	120	458	75	28	2E	28,00	100	28	2E	33,00
150 H .. MP	150	606,38	605,01	-	-	120	579	75	28	2E	32,50	100	28	2E	38,00
152 H .. MP	152	614,47	613,09	-	-	120	587	75	28	2E	35,00	100	28	2E	40,00
154 H .. MP	154	622,55	621,18	-	-	120	595	75	28	2E	38,00	100	28	2E	42,00
156 H .. MP	156	630,64	629,26	-	-	120	603	75	28	2E	41,00	100	28	2E	44,20

.. Riemenbreite in 1/100 Inch d.h. 200 oder 300

ZAHNRIEMENSCHLEIBEN VOLLNABEN XH200 / XH300 / XH400

TEILUNG: 7/8" (22,225mm)

MATERIAL:

Stahl C40 UNI 7845

Guss EN-GJL-250 UNI EN 1561

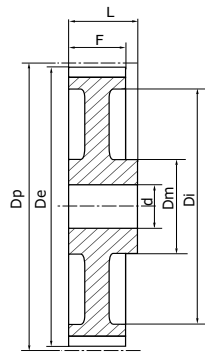

Typ 2A

leichtere Riemenscheibe

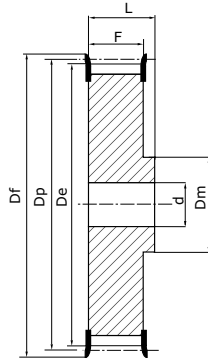

Typ 2F

Vollscheibe mit Bordscheiben

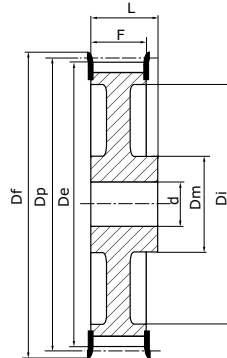

Typ 2AF

leichtere Riemenscheibe

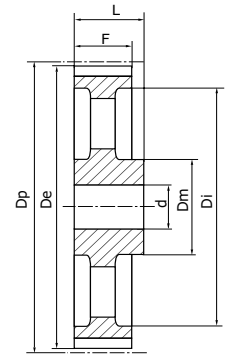

Typ 2E

Hohl-Riemenscheibe

Stahl = Z18 bis Z34

Stahl = Z38 bis Z120

Art. Nr.	Z	Dp	De	Df	Flansch	XH200 für 50,8-Riemen (F=65)					XH300 für 76,2-Riemen					XH400 für 101,6-Riemen (F=118)							
						Dm	Di	L	d	Typ	Kg	Dm	Di	L	d	Typ	Kg	Dm	Di	L	d	Typ	Kg
18 XH.. FMP	18	127,34	124,55	140	F44	100	-	80	24	2F	5,90	100	-	110	28	2F	8,90	100	-	132	32	2F	9,50
19 XH.. FMP	19	134,41	131,62	146	F46	100	-	80	24	2F	6,50	100	-	110	28	2F	9,20	100	-	132	32	2F	10,65
20 XH.. FMP	20	141,49	138,69	155	F50	100	-	80	24	2F	7,20	100	-	110	28	2F	9,50	100	-	132	32	2F	11,80
21 XH.. FMP	21	148,56	145,77	160	F51	110	-	80	24	2F	7,90	110	-	110	28	2F	10,80	110	-	132	32	2F	13,20
22 XH.. FMP	22	155,64	152,84	168	F52	110	-	80	24	2F	8,70	110	-	110	28	2F	12,10	110	-	132	32	2F	14,73
24 XH.. FMP	24	169,79	166,99	188	F81	120	-	80	24	2F	10,60	120	-	110	28	2F	14,10	120	-	132	32	2F	17,80
25 XH.. FMP	25	176,86	174,07	192	F56	120	-	80	24	2F	11,40	120	-	110	28	2F	15,40	120	-	132	32	2F	19,40
26 XH.. FMP	26	183,94	181,14	200	F59	120	-	80	24	2F	12,20	120	-	110	28	2F	16,70	120	-	132	32	2F	21,10
27 XH.. FMP	27	191,01	188,22	200	F59	120	-	80	24	2F	13,50	120	-	110	28	2F	18,40	120	-	132	32	2F	22,80
28 XH.. FMP	28	198,08	195,29	212	F61	150	-	80	24	2F	14,80	150	-	110	28	2F	20,20	150	-	132	32	2F	22,60
30 XH.. FMP	30	212,23	209,44	226	F62	150	-	80	24	2F	16,60	150	-	110	28	2F	23,80	150	-	132	32	2F	28,70
32 XH.. FMP	32	226,38	223,59	240	F64	150	184	80	24	2AF	17,90	150	-	110	28	2AF	26,60	150	-	132	32	2F	32,50
34 XH.. FMP	34	240,53	237,74	256	F66	150	198	80	24	2AF	18,20	150	198	110	28	2AF	29,40	150	-	132	32	2F	36,50
38 XH.. FMP	38	268,83	266,03	286	F69	150	227	100	28	2AF	19,00	175	227	120	32	2AF	32,00	150	227	132	32	2AF	40,00
40 XH.. FMP	40	282,98	280,18	296	F70	150	241	100	28	2AF	22,10	175	241	120	32	2AF	37,50	150	241	132	32	2AF	32,90
46 XH.. MP	46	325,42	322,63	-	-	150	283	100	28	2A	26,00	175	283	120	32	2A	32,50	175	283	132	32	2A	38,00
48 XH.. MP	48	339,57	336,78	-	-	150	297	100	28	2A	27,60	175	297	120	32	2A	34,00	175	297	132	32	2A	41,00
50 XH.. MP	50	410,32	407,52	-	-	150	368	100	28	2A	27,60	175	368	120	32	2A	37,00	175	368	132	32	2A	46,00
60 XH.. MP	60	424,47	421,67	-	-	150	382	100	28	2A	22,10	175	382	120	32	2A	39,00	175	382	132	32	2A	47,00
70 XH.. MP	70	495,21	492,42	-	-	190	453	100	28	2E	39,00	175	453	120	32	2E	53,00	175	453	132	32	2E	66,00
72 XH.. MP	72	509,36	506,56	-	-	190	467	100	28	2E	42,00	175	467	120	32	2E	55,00	175	467	132	32	2E	68,00
78 XH.. MP	78	551,81	549,01	-	-	190	510	100	28	2E	48,00	175	510	120	32	2E	62,00	175	510	132	32	2E	71,00
80 XH.. MP	80	565,95	563,16	-	-	190	524	100	28	2E	51,00	175	524	120	32	2E	64,00	175	524	132	32	2E	73,00
82 XH.. MP	82	580,1	577,31	-	-	190	538	100	28	2E	54,00	175	538	120	32	2E	66,00	175	538	132	32	2E	74,50
84 XH.. MP	84	594,25	591,46	-	-	190	552	100	28	2E	57,00	175	552	120	32	2E	69,00	175	552	132	32	2E	78,00
94 XH.. MP	94	665	662,2	-	-	190	623	100	28	2E	64,00	175	623	120	32	2E	81,00	175	623	132	32	2E	86,00
96 XH.. MP	96	679,15	676,35	-	-	190	637	100	28	2E	67,00	175	637	120	32	2E	85,00	175	637	132	32	2E	98,00
118 XH.. MP	118	834,78	831,99	-	-	190	792	100	28	2E	88,00	175	792	120	32	2E	116,00	175	792	132	32	2E	142,00
120 XH.. MP	120	848,93	846,14	-	-	190	806	100	28	2E	90,00	175	806	120	32	2E	121,00	175	806	132	32	2E	156,00

.. Riemenbreite in 1/100 Inch d.h. 200, 300 oder 400



ZAHNRIEMENSCHLEIBEN VOLLNABEN XXH200 / XXH300 / XXH400 / XXH500

TEILUNG: 1" x 1/4" (31,75 mm)

MATERIAL:

Stahl C40 UNI 7845

Guss EN-GJL-250 UNI EN 1561

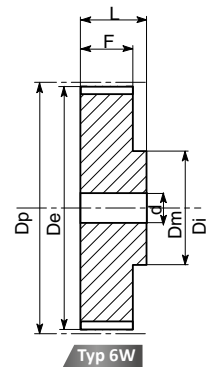
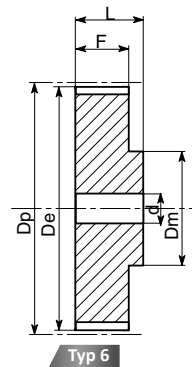
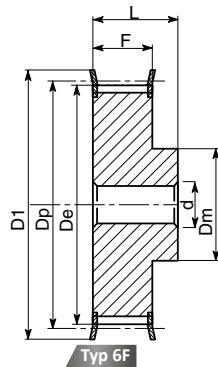

Stahl = Z18 bis Z26
Guss = Z27 bis Z340

Art. Nr.	Z	Dp	De	Df	Flansch	XXH200 für 50,8-Riemen (F=64,2)						XXH300 für 76,2-Riemen (F=91,4)					
						Dm	Di	L	d	Typ	Kg	Dm	Di	L	d	Typ	Kg
18 XXH.. FMP	18	181,91	178,87	198	F58	140	-	100	28	6F	14,2	140	-	110	28	6F	16,0
19 XXH.. FMP	19	192,02	188,97	205	F60	140	-	100	28	6F	15,8	140	-	110	28	6F	18,4
20 XXH.. FMP	20	202,13	199,08	212	F61	150	-	100	28	6F	17,3	150	-	110	28	6F	20,4
21 XXH.. FMP	21	212,23	202,19	226	F62	150	-	100	28	6F	18,5	150	-	110	28	6F	22,0
22 XXH.. FMP	22	222,34	219,29	240	F64	150	-	100	28	6F	20,0	150	-	110	28	6F	25,0
24 XXH.. FMP	24	242,55	239,50	-	-	150	-	100	28	6	23,6	150	-	110	28	6	29,2
25 XXH.. FMP	25	252,66	249,61	-	-	150	196	100	28	6W	18,0	150	196	110	28	6W	24,6
26 XXH.. FMP	26	262,76	259,76	-	-	150	207	100	28	6W	20,0	150	207	110	28	6W	27,0
27 XXH.. FMP	27	272,87	269,82	-	-	150	216	100	28	6W	24,0	150	216	110	28	6W	29,0
30 XXH.. FMP	30	303,19	300,14	-	-	150	247	100	28	6W	26,0	150	247	110	28	6W	31,0
34 XXH.. FMP	34	343,62	340,57	-	-	150	287	100	28	6W	31,8	150	287	110	28	6W	39,0

Stahl = Z18 bis Z26
Guss = Z27 bis Z340

Art. Nr.	Z	Dp	De	Df	Nr. Flan.	XXH400 für 101,6 Riemen (F=120,7)						XXH500 für 127 mm-Riemen (F=145,3)					
						Dm	Di	L	d	Typ	Kg	Dm	Di	L	d	Typ	Kg
18 XXH.. FMP	18	181,91	178,87	198	F58	140	-	140	32	6F	20,8	140	-	168	32	6F	24,0
19 XXH.. FMP	19	192,02	188,97	205	F60	140	-	140	32	6F	24,0	140	-	168	32	6F	28,0
20 XXH.. FMP	20	202,13	199,08	212	F61	150	-	140	32	6F	26,0	150	-	168	32	6F	31,4
21 XXH.. FMP	21	212,23	202,19	226	F62	150	-	140	32	6F	28,5	150	-	168	32	6F	34,0
22 XXH.. FMP	22	222,34	219,29	240	F64	150	-	140	32	6F	31,6	150	-	168	32	6F	38,3
24 XXH.. FMP	24	242,55	239,50	-	-	150	-	140	32	6	35,0	150	-	168	32	6	45,0
25 XXH.. FMP	25	252,66	249,61	-	-	150	196	140	32	6W	28,0	150	196	168	32	6W	36,0
26 XXH.. FMP	26	262,76	259,76	-	-	150	207	140	32	6W	32,4	150	207	168	32	6W	37,5
27 XXH.. FMP	27	272,87	269,82	-	-	150	216	140	32	6W	34,0	150	216	168	32	6W	42,0
30 XXH.. FMP	30	303,19	300,14	-	-	185	247	140	32	6W	36,0	215	247	168	32	6W	46,8
34 XXH.. FMP	34	343,62	340,57	-	-	185	287	140	32	6W	47,6	215	287	168	32	6W	57,0

.. Riemenbreite in 1/100 Inch d.h. 200, 300, 400 oder 500

ZAHNRIEMENSCHLEIBEN VOLLNABEN „HTD“ 3M / 5M

3M - TEILUNG: 3 MM

5M - TEILUNG: 5 MM

MATERIAL:

Stahl C40 UNI 7845

Aluminium 6082T6 UNI

9006/4

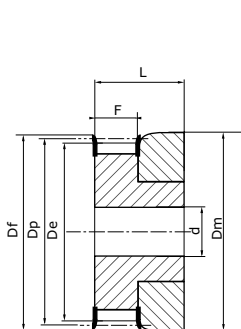

Typ 1F

Vollscheibe mit Bordscheiben

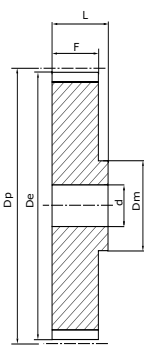

Typ 2

Vollscheibe

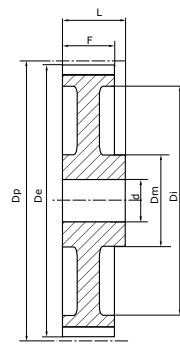

Typ 2A

leichtere Riemenscheibe

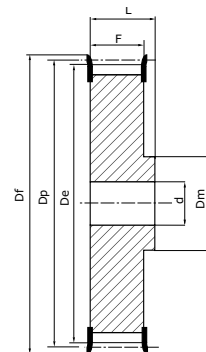

Typ 2F

Vollscheibe mit Bordscheiben

Aluminium = Z10 bis Z72

Art. Nr.	Z	Dp	De	Df	Flansch	Dm	3M-09 für 9 mm-Riemen					3M-15 für 15 mm-Riemen				
							F	L	d	Typ	Kg	F	L	d	Typ	Kg
10 03M .. FMP	10	9,55	8,79	13	F01	13	10,2	17,5	4	1F	0,004	17	22	4	1F	0,002
12 03M .. FMP	12	11,46	10,70	15	F02	15	10,2	17,5	4	1F	0,002	17	22	4	1F	0,008
14 03M .. FMP	14	13,37	12,61	16	F03	16	10,2	17,5	4	1F	0,007	17	22	4	1F	0,010
15 03M .. FMP	15	14,32	13,56	17,5	F04	17,5	10,2	17,5	4	1F	0,008	17	22	4	1F	0,012
16 03M .. FMP	16	15,28	14,52	18	F05	18	12,8	20,6	4	2F	0,007	19,05	22	4	2F	0,010
18 03M .. FMP	18	17,19	16,43	20	F06	11	12,8	20,6	6	2F	0,008	19,05	22	6	2F	0,012
20 03M .. FMP	20	19,10	18,34	23	F07	13	12,8	20,6	6	2F	0,010	19,05	22	6	2F	0,014
21 03M .. FMP	21	20,05	19,29	25	F08	13	12,8	20,6	6	2F	0,013	19,05	22	6	2F	0,012
22 03M .. FMP	22	21,01	20,25	25	F08	13	12,8	20,6	6	2F	0,014	19,05	22	6	2F	0,018
24 03M .. FMP	24	22,92	22,16	25	F08	13	12,8	20,6	6	2F	0,012	19,05	22	6	2F	0,020
26 03M .. FMP	26	24,83	24,07	28	F09	16	12,8	20,6	6	2F	0,018	19,05	22	6	2F	0,027
28 03M .. FMP	28	26,74	25,98	32	F10	18	12,8	20,6	6	2F	0,024	19,05	22	6	2F	0,030
30 03M .. FMP	30	28,65	27,89	32	F10	20	12,8	20,6	6	2F	0,028	19,05	22	6	2F	0,035
32 03M .. FMP	32	30,56	29,80	36	F12	22	12,8	20,6	6	2F	0,032	19,05	22	6	2F	0,042
36 03M .. FMP	36	34,38	33,62	38	F14	26	13,4	22,2	6	2F	0,045	20	30	6	2F	0,020
40 3M .. FMP	40	38,20	37,44	42	F15	28	13,4	22,2	6	2F	0,055	20	30	6	2F	0,075
44 03M .. FMP	44	42,02	41,26	48	F18	33	13,4	22,2	6	2F	0,074	20	30	6	2F	0,095
48 03M .. MP	48	45,84	45,08	-	-	33	13,4	22,2	8	2	0,074	20	30	8	2	0,103
60 03M .. MP	60	57,30	56,54	-	-	33	13,4	22,2	8	2	0,102	20	30	8	2	0,150
72 03M .. MP	72	68,75	67,99	-	-	33	13,4	22,2	8	2	0,145	20	30	8	2	0,212

.. Riemenbreite in mm d.h. 09 oder 15

Stahl = Z12 bis Z40

Aluminium = Z44 bis Z72

Art. Nr.	Z	Dp	De	Df	Flansch	Dm	Di	5M-09 für 9 mm-Riemen					5M-15 für 15 mm-Riemen					5M-25 für 25 mm-Riemen				
								F	L	d	Typ	Kg	F	L	d	Typ	Kg	F	L	d	Typ	Kg
12 05M .. FMP	12	19,10	17,96	23	F07	12	-	14,5	20	4	2F	0,028	20,5	26	4	2F	0,034	30,5	36	4	2F	0,050
14 05M .. FMP	14	22,28	21,14	25	F08	13	-	14,5	20	6	2F	0,034	20,5	26	6	2F	0,046	30,5	36	6	2F	0,070
15 05M .. FMP	15	23,87	22,73	28	F09	16	-	14,5	20	6	2F	0,042	20,5	26	6	2F	0,056	30,5	36	6	2F	0,080
16 05M .. FMP	16	25,46	24,32	28	F09	16,5	-	14,5	20	6	2F	0,050	20,5	26	6	2F	0,064	30,5	36	6	2F	0,100
18 05M .. FMP	18	28,65	27,51	32	F10	20	-	14,5	20	6	2F	0,070	20,5	26	6	2F	0,086	30,5	36	6	2F	0,120
20 05M .. FMP	20	31,83	30,69	36	F12	23	-	14,5	22,5	6	2F	0,094	20,5	26	6	2F	0,112	30,5	36,5	6	2F	0,160
21 05M .. FMP	21	33,42	32,28	38	F14	24	-	14,5	22,5	6	2F	0,110	20,5	26	6	2F	0,130	30,5	38,5	6	2F	0,190
22 05M .. FMP	22	35,01	33,87	38	F14	25,5	-	14,5	22,5	6	2F	0,118	20,5	26	6	2F	0,140	30,5	38,5	6	2F	0,210
24 05M .. FMP	24	38,20	37,06	42	F15	27	-	14,5	22,5	6	2F	0,145	20,5	28	6	2F	0,180	30,5	38,5	6	2F	0,250
26 05M .. FMP	26	41,38	40,24	44	F17	30	-	14,5	22,5	6	2F	0,170	20,5	28	6	2F	0,220	30,5	38,5	6	2F	0,300
28 05M .. FMP	28	44,56	43,42	48	F18	30,5	-	14,5	22,5	6	2F	0,200	20,5	28	6	2F	0,250	30,5	38,5	6	2F	0,350
30 05M .. FMP	30	47,75	46,60	51	F19	35	-	14,5	22,5	6	2F	0,236	20,5	28	6	2F	0,300	30,5	38,5	6	2F	0,420
32 05M .. FMP	32	50,93	49,79	54	F20	38	-	14,5	22,5	8	2F	0,210	20,5	28	8	2F	0,350	30,5	38,5	8	2F	0,480
36 05M .. FMP	36	57,30	56,16	60	F22	38	-	14,5	22,5	8	2F	0,324	20,5	28	8	2F	0,426	30,5	38,5	8	2F	0,590
40 05M .. FMP	40	63,66	62,52	70	F26	38	-	14,5	22,5	8	2F	0,400	20,5	28	8	2F	0,520	30,5	38,5	8	2F	0,740
44 05M .. MP	44	70,03	68,89	-	-	38	54	14,5	25,5	8	2A	0,170	20,5	30	8	2A	0,225	30,5	40,5	8	2A	0,320
48 05M .. MP	48	76,39	75,25	-	-	45	61	14,5	25,5	8	2A	0,182	20,5	30	8	2A	0,187	30,5	40,5	8	2A	0,275
60 05M .. MP	60	95,46	94,35	-	-	45	80	14,5	25,5	8	2A	0,230	20,5	30	8	2A	0,305	30,5	40,5	8	2A	0,435
72 05M .. MP	72	114,59	113,45	-	-	45	100	14,5	25,5	8	2A	0,270	20,5	30	8	2A	0,305	30,5	40,5	8	2A	0,525

.. Riemenbreiten in mm d.h. 09, 15 oder 25



ZAHNRIEMENSCHLEIBEN VOLLNABEN „HTD“ 8M

TEILUNG: 8 mm
MATERIAL:
 Stahl C40 UNI 7845
 Guss EN-GJL-250 UNI EN 1561

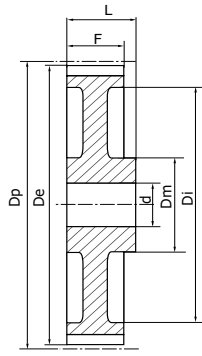

Typ 2A
 leichtere Riemenscheibe

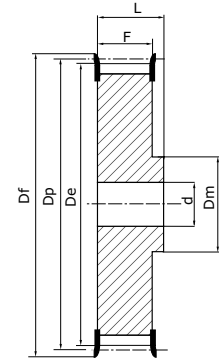

Typ 2F
 Vollscheibe mit Bordscheiben

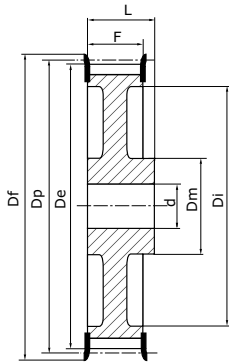

Typ 2AF
 leichtere Riemenscheibe

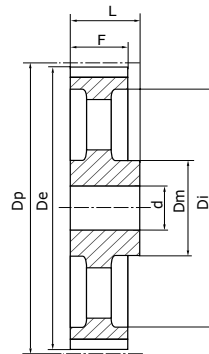

Typ 2E
 Hohl-Riemenscheibe

Stahl = Z22 bis Z72
Guss = Z80 bis Z192

Art. Nr.	Z	Dp	De	Df	Nr. Flan.	Dm	8M-20 für 20 mm-Riemen (F=28)					8M-30 für 30 mm-Riemen (F=38)				
							Di	L	d	Typ	Kg	Di	L	d	Typ	Kg
22 08M .. FMP	22	56,02	54,65	60	F23	43	-	38	12	2F	0,54	-	48	12	2F	0,69
24 08M .. FMP	24	61,12	59,75	66	F26	45	-	38	12	2F	0,65	-	48	12	2F	0,84
26 08M .. FMP	26	66,21	64,84	70	F27	48	-	38	12	2F	0,80	-	48	12	2F	1,00
28 08M .. FMP	28	71,30	70,08	75	F28	50	-	38	15	2F	0,87	-	48	15	2F	1,12
30 08M .. FMP	30	76,39	75,13	83	F30	55	-	38	15	2F	1,02	-	48	15	2F	1,32
32 08M .. FMP	32	81,49	80,16	87	F31	60	-	38	15	2F	1,20	-	48	15	2F	1,53
34 08M .. FMP	34	86,58	85,22	91	F32	70	-	38	15	2F	1,40	-	48	15	2F	1,80
36 08M .. FMP	36	91,67	90,30	97	F34	75	-	38	15	2F	1,55	-	48	15	2F	1,99
38 08M .. FMP	38	96,77	95,39	102	F35	75	-	38	15	2F	1,65	-	48	15	2F	2,27
40 08M .. FMP	40	101,86	100,49	106	F37	75	-	38	15	2F	1,74	-	48	15	2F	2,40
44 08M .. FMP	44	112,05	110,67	120	F39	75	-	38	15	2F	2,10	-	48	15	2F	2,80
48 08M .. FMP	48	122,23	120,86	128	F40	75	-	38	15	2F	2,44	-	48	15	2F	3,20
56 08M .. FMP	56	142,60	141,23	150	F43	80	116	38	15	2AF	2,60	116	48	15	2AF	3,60
64 08M .. FMP	64	162,97	161,60	168	F45	80	137	38	15	2AF	2,90	137	48	15	2AF	4,30
72 08M .. FMP	72	183,35	181,97	192	F48	80	158	38	15	2AF	3,10	158	48	15	2AF	4,80
80 08M .. MP	80	203,72	202,35	-	-	90	180	38	15	2A	3,80	180	48	15	2A	5,10
90 08M .. MP	90	229,18	227,81	-	-	90	204	38	15	2E	4,20	204	48	15	2E	5,70
112 08M .. MP	112	285,21	283,83	-	-	90	254	38	18	2E	5,20	254	48	18	2E	6,80
144 08M .. MP	144	366,69	365,32	-	-	90	336	38	20	2E	7,50	336	48	20	2E	9,30
168 08M .. MP	168	427,81	426,44	-	-	100	400	38	20	2E	10,00	400	48	20	2E	11,40
192 08M .. MP	192	488,92	487,55	-	-	100	460	38	20	2E	14,40	460	48	20	2E	16,00

.. Riemenbreite in mm d.h. 20 oder 30



ZAHNRIEMENSCHLEIBEN VOLLNABEN „HTD“ 8M

TEILUNG: 8 mm
MATERIAL:
 Stahl C40 UNI 7845
 Guss EN-GJL-250 UNI EN 1561

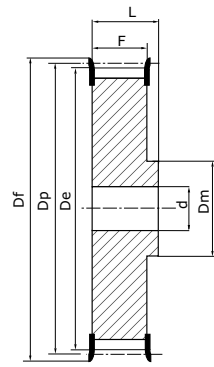
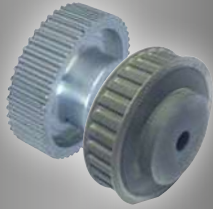

Typ 2F
Vollscheibe mit Bordscheiben

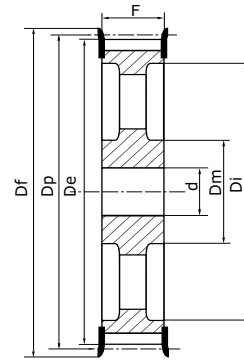

Typ 3EF
Hohl-Riemenscheibe

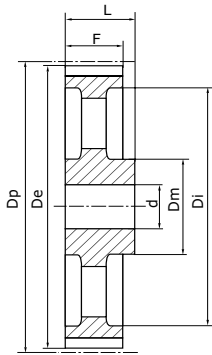

Typ 2E
Hohl-Riemenscheibe

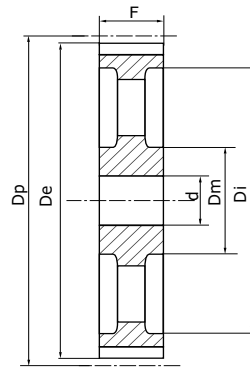

Typ 3E
Hohl-Riemenscheibe

Stahl = Z22 bis Z72
Guss = Z80 bis Z192

Art. Nr.	Z	Dp	De	Df	Flansch	Dm	8M-50 für 50 mm-Riemen (F=60)					8M-85 für 85 mm-Riemen (F=95)				
							Di	L	d	Typ	Kg	Di	L	d	Typ	Kg
22 08M .. FMP	22	56,02	54,65	60	F23	43	-	70	12	2F	1,00	-	105	12	2F	1,55
24 08M .. FMP	24	61,12	59,75	66	F26	45	-	70	12	2F	1,23	-	105	12	2F	1,90
26 08M .. FMP	26	66,21	64,84	70	F27	48	-	70	12	2F	1,50	-	105	12	2F	2,25
28 08M .. FMP	28	71,30	70,08	75	F28	50	-	70	15	2F	1,67	-	105	15	2F	2,55
30 08M .. FMP	30	76,39	75,13	83	F30	55	-	70	15	2F	1,97	-	105	15	2F	3,00
32 08M .. FMP	32	81,49	80,16	87	F31	60	-	70	15	2F	2,27	-	105	15	2F	3,57
34 08M .. FMP	34	86,58	85,22	91	F32	66	-	70	15	2F	2,69	-	105	15	2F	4,00
36 08M .. FMP	36	91,67	90,30	97	F34	70	-	70	15	2F	2,97	-	105	15	2F	4,50
38 08M .. FMP	38	96,77	95,39	102	F35	75	-	70	15	2F	3,23	-	105	15	2F	5,00
40 08M .. FMP	40	101,86	100,49	106	F37	75	-	70	18	2F	3,50	-	105	18	2F	5,20
44 08M .. FMP	44	112,05	110,67	120	F39	75	-	70	18	2F	3,90	-	105	18	2F	6,60
48 08M .. FMP	48	122,23	120,86	128	F40	80	-	70	18	2F	4,30	-	105	18	2F	7,00
56 08M .. FMP	56	142,60	141,23	150	F43	90	116	60	18	3EF	5,00	-	95	18	2F	10,00
64 08M .. FMP	64	162,97	161,60	168	F45	100	137	60	18	3EF	5,60	137	95	20	3EF	10,40
72 08M .. FMP	72	183,35	181,97	192	F48	100	158	60	18	3EF	6,80	158	95	20	3EF	11,40
80 08M .. MP	80	203,72	202,35	-	-	110	180	60	18	3E	6,90	180	95	20	3E	11,10
90 08M .. MP	90	229,18	227,81	-	-	110	204	60	18	3E	8,60	204	95	20	3E	12,20
112 08M .. MP	112	285,21	283,83	-	-	110	254	60	18	3E	9,60	254	95	24	3E	15,00
144 08M .. MP	144	366,69	365,32	-	-	110	336	60	20	3E	13,80	336	95	24	3E	21,50
168 08M .. MP	168	427,81	426,44	-	-	120	400	60	20	3E	16,00	400	95	24	3E	24,10
192 08M .. MP	192	488,92	487,55	-	-	130	460	60	20	3E	22,40	460	95	24	3E	30,60

.. Riemenbreite in mm d.h. 50 oder 85



ZAHNRIEMENSCHLEIBEN VOLLNABEN „HTD“ 14M

TEILUNG: 14 mm
 MATERIAL:
 Stahl C40 UNI 7845
 Guss EN-GJL-250 UNI EN 1561

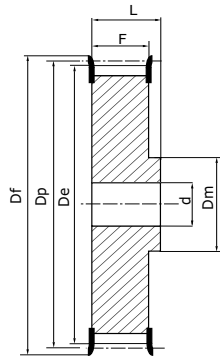
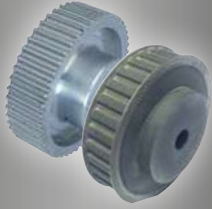

Typ 2F
 Vollscheibe mit Bordscheiben

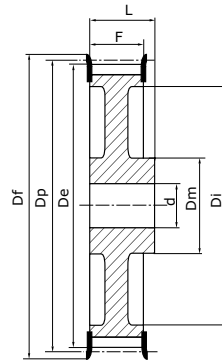

Typ 2AF
 leichtere Riemenscheibe

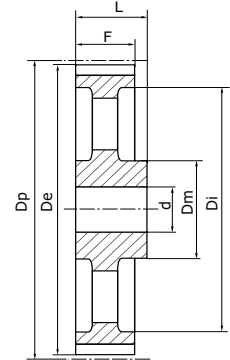

Typ 2E
 Hohl-Riemenscheibe

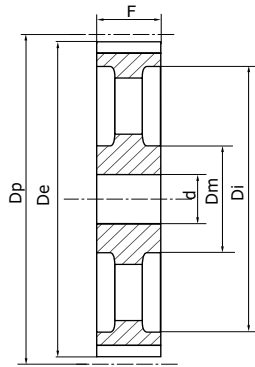

Typ 3E
 Hohl-Riemenscheibe

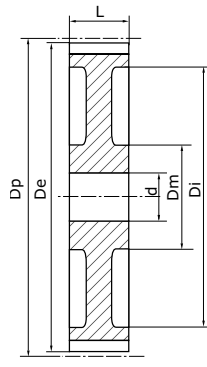

Typ 3A
 Riemenscheibe

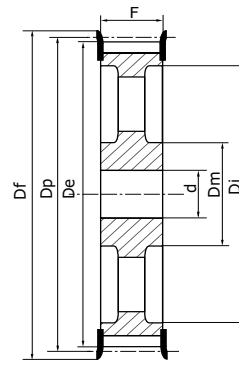

Typ 3EF
 Hohl-Riemenscheibe

Stahl = Z28 bis Z44
 Guss = Z48 bis Z216

Art. Nr.	Z	Dp	De	Df	Flansch	14M-40 für 40 mm-Riemen (F=54)						14M-55 für 55 mm-Riemen (F=70)						14M-85 für 85 mm-Riemen (F=102)					
						Dm	Di	L	d	Typ	Kg	Dm	Di	L	d	Typ	Kg	Dm	Di	L	d	Typ	Kg
28 14M .. FMP	28	124,78	122,12	128	F40	100	-	69	24	2F	4,73	100	-	85	24	2F	5,60	100	-	117	24	2F	7,70
29 14M .. FMP	29	129,23	126,57	138	F43	100	-	69	24	2F	5,09	100	-	85	24	2F	6,10	100	-	117	24	2F	8,40
30 14M .. FMP	30	133,69	130,99	138	F43	100	-	69	24	2F	5,45	100	-	85	24	2F	6,60	100	-	117	24	2F	9,10
32 14M .. FMP	32	142,60	139,88	154	F49	100	-	69	24	2F	6,17	100	-	85	24	2F	7,60	100	-	117	24	2F	10,50
34 14M .. FMP	34	151,52	148,79	160	F51	100	-	69	24	2F	6,88	100	-	85	24	2F	8,60	100	-	117	24	2F	11,90
36 14M .. FMP	36	160,43	157,68	168	F52	100	-	69	24	2F	7,60	100	-	85	24	2F	9,60	100	-	117	32	2F	13,20
38 14M .. FMP	38	169,34	166,60	184	F81	120	-	69	24	2F	8,28	120	-	85	24	2F	10,80	120	-	117	32	2F	15,15
40 14M .. FMP	40	178,25	175,49	188	F56	120	-	69	24	2F	9,26	120	-	85	24	2F	11,20	135	-	117	32	2F	17,10
44 14M .. FMP	44	196,08	193,28	212	F61	120	-	69	24	2F	10,32	120	-	85	24	2F	12,50	135	-	117	32	2F	23,30
48 14M .. FMP	48	213,90	211,11	226	F62	135	170	69	24	2AF	11,50	135	170	85	24	2F	13,70	150	-	117	32	2F	25,00
56 14M .. FMP	56	249,55	246,76	256	F66	135	207	69	28	2AF	13,05	135	207	85	28	3EF	14,50	150	207	117	32	3EF	25,00
64 14M .. FMP	64	285,21	282,41	296	F70	135	240	69	28	2AF	14,40	135	240	85	28	3EF	15,60	150	240	102	32	3EF	30,50
72 14M .. MP	72	320,86	318,06	-	-	135	278	69	28	2E	16,90	135	278	85	28	3E	16,90	150	278	102	32	3E	28,80
80 14M .. MP	80	356,51	353,71	-	-	135	314	69	28	2E	18,50	135	314	85	28	3E	20,00	150	314	102	32	3E	30,10
90 14M .. MP	90	401,07	398,28	-	-	135	358	69	28	2E	20,00	135	358	85	28	3E	22,60	150	358	102	32	3E	33,00
112 14M .. MP	112	499,11	496,32	-	-	135	456	69	28	2E	26,70	135	456	85	28	3E	29,50	150	456	102	32	3E	41,80
144 14M .. MP	144	641,71	638,92	-	-	135	600	69	28	2E	35,00	135	600	85	28	3E	39,00	150	600	102	32	3E	52,40
168 14M .. MP	168	748,66	745,87	-	-	135	706	69	28	2E	44,20	135	706	85	28	3E	48,50	150	706	102	32	3E	60,30
192 14M .. MP	192	855,62	852,82	-	-	135	813	69	28	2E	52,20	135	813	85	28	3E	57,80	165	813	102	32	3E	70,20
216 14M .. MP	216	962,57	959,76	-	-	150	920	69	28	2E	62,50	150	920	85	28	3E	67,00	160	920	102	32	3E	81,00

.. Riemenbreite in mm d.h. 40, 55 oder 85

ZAHNRIEMENSCHLEIBEN VOLLNABEN „HTD“ 14M

TEILUNG: 14 mm
MATERIAL:
 Stahl C40 UNI 7845
 Guss EN-GJL-250 UNI EN 1561

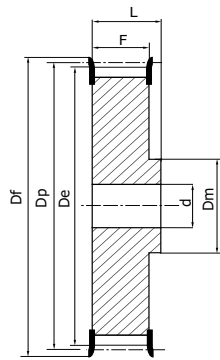

Typ 2F
 Vollscheibe mit Bordscheiben

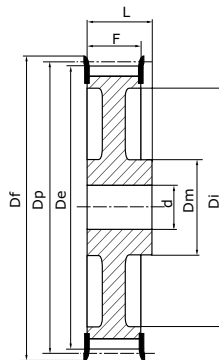

Typ 2AF
 leichtere Riemscheibe

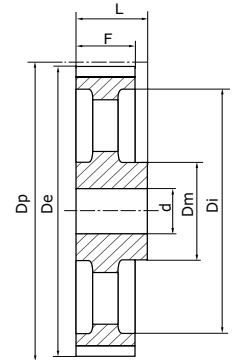

Typ 2E
 Hohl-Riemscheibe

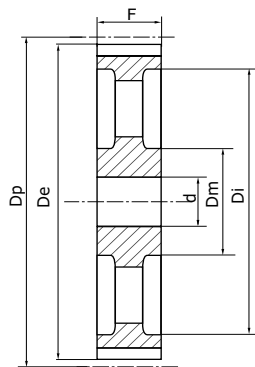

Typ 3E
 Hohl-Riemscheibe

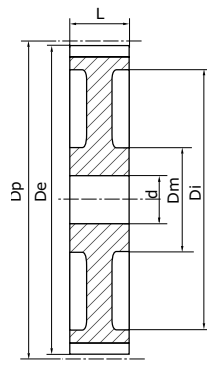

Typ 3A
 Riemscheibe

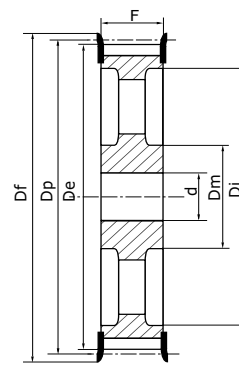

Typ 3EF
 Hohl-Riemscheibe

Stahl = Z28 bis Z64
Guss = Z72 bis Z216

für 115 mm-Riemen (F=145,3)

14M-170
 für 170 mm-Riemen (F=187)

Art. Nr.	Z	Dp	De	Df	Flansch	für 115 mm-Riemen (F=145,3)						14M-170 für 170 mm-Riemen (F=187)					
						Dm	Di	L	d	Typ	Kg	Dm	Di	L	d	Typ	Kg
28 14M .. FMP	28	124,78	122,12	128	F40	100	-	148	32	2F	9,20	100	-	202	32	2F	13,80
29 14M .. FMP	29	129,23	126,57	138	F43	100	-	148	32	2F	10,20	100	-	202	32	2F	14,20
30 14M .. FMP	30	133,69	130,99	138	F43	100	-	148	32	2F	11,20	100	-	202	32	2F	15,60
32 14M .. FMP	32	142,60	139,88	154	F49	100	-	148	32	2F	13,20	100	-	202	32	2F	18,10
34 14M .. FMP	34	151,52	148,79	160	F51	100	-	148	32	2F	14,80	100	-	202	32	2F	20,40
36 14M .. FMP	36	160,43	157,68	168	F52	100	-	148	32	2F	16,60	120	-	202	32	2F	23,50
38 14M .. FMP	38	169,34	166,60	184	F81	120	-	148	32	2F	19,20	135	-	202	32	2F	26,50
40 14M .. FMP	40	178,25	175,49	188	F56	135	-	148	32	2F	20,56	135	-	202	32	2F	30,10
44 14M .. FMP	44	196,08	193,28	212	F61	135	-	148	32	2F	21,93	140	-	202	32	2F	37,80
48 14M .. FMP	48	213,90	211,11	226	F62	150	-	148	32	2F	25,00	150	-	202	32	2F	44,50
56 14M .. FMP	56	249,55	246,76	256	F66	150	-	148	32	2F	27,50	150	-	202	32	2F	61,00
64 14M .. FMP	64	285,21	282,41	296	F70	150	240	133	32	3EF	30,10	150	240	202	32	2F	81,00
72 14M .. MP	72	320,86	318,06	-	-	150	278	133	32	3E	32,83	150	278	187	32	3A	61,40
80 14M .. MP	80	356,51	353,71	-	-	150	314	133	32	3E	35,55	150	314	187	32	3A	65,00
90 14M .. MP	90	401,07	398,28	-	-	150	358	133	32	3E	41,00	150	358	187	32	3E	68,00
112 14M .. MP	112	499,11	496,32	-	-	150	456	133	32	3E	54,40	150	456	187	32	3E	87,50
144 14M .. MP	144	641,71	638,92	-	-	150	600	133	32	3E	67,80	165	600	187	32	3E	114,00
168 14M .. MP	168	748,66	745,87	-	-	150	706	133	32	3E	75,80	165	706	187	32	3E	125,00
192 14M .. MP	192	855,62	852,82	-	-	165	813	133	32	3E	88,30	165	813	187	32	3E	136,40
216 14M .. MP	216	962,57	959,76	-	-	160	920	133	32	3E	98,00	165	920	187	32	3E	147,00

.. Riemenbreite in mm d.h. 117 oder 170



ZAHNRIEMENSCHLEIBEN FÜR KLEMMBUCHSEN L050 / L075 / L100

TEILUNG: 3/8" (9,525 mm)

MATERIAL:

Stahl C40 UNI 7845

Guss EN-GJL-250 UNI EN 1561

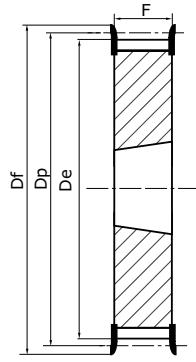
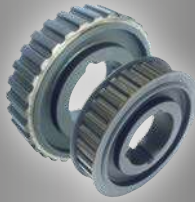

Typ 4F

Vollscheibe mit Bordscheiben

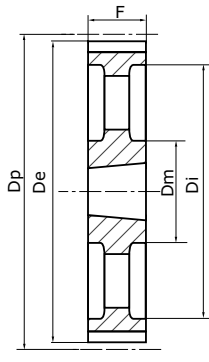

Typ 4E

Hohl-Riemenscheibe

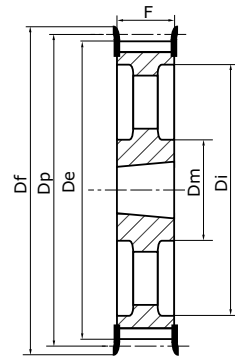

Typ 4EF

Hohl-Riemenscheibe

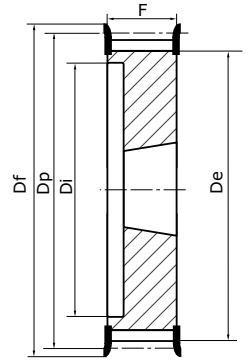

Typ 6F

Vollscheibe mit Bordscheiben

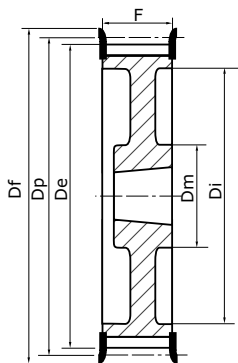

Typ 6AF

leichtere Riemenscheibe

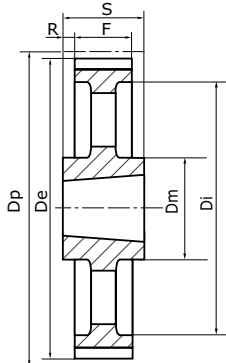

Typ 7E

Hohl-Riemenscheibe

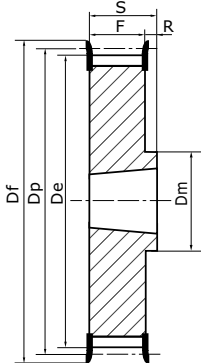

Typ 8F

Vollscheibe mit Bordscheiben

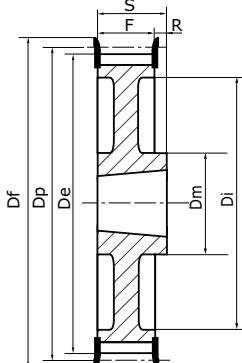

Typ 8AF

leichtere Riemenscheibe

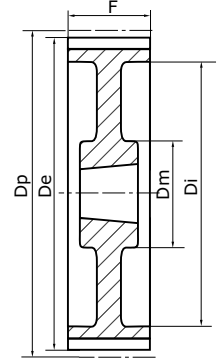

Typ 9A

leichtere Riemenscheibe

Stahl = Z18 bis Z60
Guss = Z72 bis Z120

Art. Nr.	Z	Nr. Flan.	Dp	De	Df	L050 für 12,7-Riem				L075 für 19,05-Riem				L100 für 25,4-Riem															
						Dm	Di	F	S	R	Buchse	Typ	Kg	Dm	Di	F	S	R	Buchse	Typ	Kg	Dm	Di	F	S	R	Buchse	Typ	Kg
18 L..FMA	18	F22	54,57	53,81	60	45	-	19	22	3	1108	8F	0,20	-	-	25	22	-	1108	4F	0,20	-	38	31	22	9	1108	6F	0,20
19 L..FMA	19	F24	57,61	56,84	64	45	-	19	22	3	1108	8F	0,20	-	-	25	22	-	1108	4F	0,30	-	38	31	22	9	1108	6F	0,30
20 L..FMA	20	F25	60,64	59,88	66	48	-	19	22	3	1108	8F	0,20	-	-	25	22	-	1108	4F	0,30	-	45	31	22	9	1108	6F	0,40
21 L..FMA	21	F26	63,67	62,91	70	48	-	19	22	3	1108	8F	0,30	-	-	25	22	-	1108	4F	0,40	-	45	31	22	9	1108	6F	0,40
22 L..FMA	22	F27	66,70	65,94	75	51	-	19	22	3	1108	8F	0,30	-	-	25	22	-	1108	4F	0,40	-	48	31	22	9	1108	6F	0,40
23 L..FMA	23	F28	69,73	68,97	79	54	-	19	22	3	1108	8F	0,40	-	-	25	22	-	1108	4F	0,40	-	52	32	22	10	1108	6F	0,50
24 L..FMA	24	F28	72,77	72,00	79	54	-	19	22	3	1108	8F	0,40	-	-	25	22	-	1108	4F	0,50	-	52	32	22	10	1108	6F	0,60
25 L..FMA	25	F29	75,80	75,04	83	56	-	19	22	3	1108	8F	0,50	-	-	25	22	-	1108	4F	0,60	-	54	32	22	10	1108	6F	0,60
26 L..FMA	26	F30	78,83	78,07	87	60	-	19	22	3	1108	8F	0,50	-	-	25	22	-	1108	4F	0,60	-	60	32	22	10	1108	6F	0,70
27 L..FMA	27	F30	81,86	81,10	87	62	-	19	22	3	1108	8F	0,60	-	-	25	22	-	1108	4F	0,70	-	60	32	22	10	1108	6F	0,80
28 L..FMA	28	F31	84,89	84,13	91	65	-	19	22	3	1108	8F	0,60	-	-	25	22	-	1108	4F	0,70	-	65	32	22	10	1108	6F	0,80
30 L..FMA	30	F33	90,96	90,20	97	70	-	19	22	3	1108	8F	0,80	-	-	25	22	-	1108	4F	0,90	-	71	32	25	10	1210	6F	0,90
32 L..FMA	32	F34	97,02	96,26	102	74	-	19	22	3	1108	8F	0,90	-	-	25	22	-	1108	4F	1,00	-	75	32	25	7	1210	6F	1,00
36 L..FMA	36	F37	109,15	108,39	115	85	-	19	22	3	1108	8F	1,20	-	-	25	22	-	1610	4F	1,20	-	86	32	25	7	1610	6F	1,40
40 L..FMA	40	F40	121,28	120,51	128	88	-	19	25	3	1610	8F	1,50	-	-	25	22	-	1610	4F	1,70	-	96	32	25	7	1610	6F	1,70
44 L..FMA	44	F48	145,53	144,77	150	88	120	19	25	6	1610	8AF	2,30	92	120	25	25	-	1610	4EF	2,50	92	120	32	25	7	1610	6AF	2,70
48 L..FMA	48	F45	133,40	132,64	-	88	110	19	25	6	1610	8F	1,80	90	110	25	25	-	1610	4EF	2,50	90	110	32	25	-	1610	6AF	2,30
60 L..MA	60	-	181,91	181,15	-	92	166	19	25	6	1610	7E	2,00	92	166	25	25	-	1610	4EF	3,00	92	166	32	25	3,5	1610	9A	2,40
72 L..MA	72	-	218,30	217,53	-	92	202	19	25	6	1610	7E	3,00	92	202	25	25	-	1610	4E	4,00	92	202	32	32	-	2012	4E	4,40
84 L..MA	84	-	254,68	253,90	-	92	236	19	25	13	1610	7E	4,00	92	236	25	32	3,5	2012	7E	5,20	92	236	32	32	-	2012	4E	6,00
96 L..MA	96	-	291,06	290,30	-	106	270	19	32	13	2012	7E	5,50	106	270	25	32	3,5	2012	7E	6,50	106	270	32	32	-	2012	4E	7,10
120 L..MA	120	-	363,83	363,07	-	106	343	19	32	13	2012	7E	6,80	106	343	25	32	3,5	2012	7E	7,60	106	343	32	32	-	2012	4E	8,50

.. Riemensbreite in 1/100 Inch d.h. 050, 075 oder 100



ZAHNRIEMENSCHLEIBEN FÜR KLEMMBUCHSEN H100 - H150

TEILUNG: 12,7 X 7,75 MM
MATERIAL:
 Stahl C40 UNI 7845
 Guss EN-GJL-250 UNI EN 1561

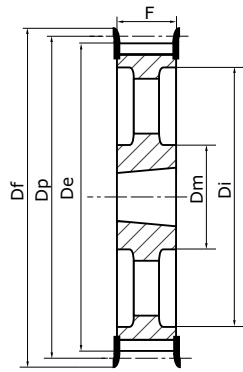

Typ 4EF
Hohl-Riemenscheibe

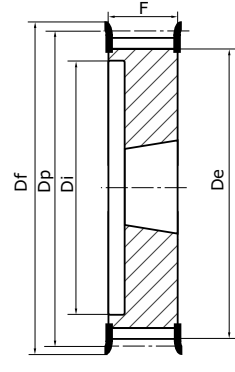

Typ 6F
Vollscheibe mit Bordscheiben

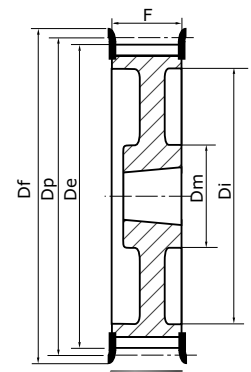

Typ 6AF
leichtere Riemenscheibe

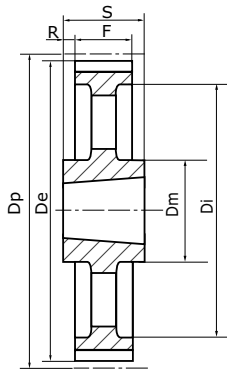

Typ 7E
Hohl-Riemenscheibe

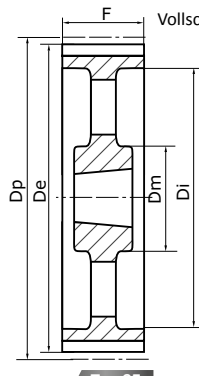

Typ 9E
Hohl-Riemenscheibe

Stahl = Z16 bis Z48
Guss = Z60 bis Z120

H100 für 25,4-Riem										
Di	F	S	R	Buchse	Typ	Kg				

H150 für 38,10-Riem						
Di	F	S	R	Buchse	Typ	Kg

Art. Nr.	Z	Flansch	Dp	De	Df	Dm	Di	F	S	R	Buchse	Typ	Kg	Di	F	S	R	Buchse	Typ	Kg
16 H .. FMA	16	F26	64,68	63,31	70	-	45	31	22	9	1108	6F	0,40	-	-	-	-	-	-	-
18 H .. FMA	18	F28	72,77	71,39	79	-	52	31	25	6	1210	6F	0,50	52	45	25	20	1210	6F	0,60
19 H .. FMA	19	F29	76,81	75,44	83	-	56	31	25	6	1210	6F	0,60	56	45	25	20	1210	6F	0,70
20 H .. FMA	20	F30	80,85	79,48	87	-	60	31	25	6	1210	6F	0,70	60	45	25	20	1210	6F	0,80
21 H .. FMA	21	F31	84,89	83,52	91	-	64	32	25	7	1210	6F	0,80	64	45	25	20	1210	6F	1,00
22 H .. FMA	22	F32	88,94	87,56	93	-	67	32	25	7	1210	6F	0,90	67	45	25	20	1210	6F	1,20
23 H .. FMA	23	F33	92,98	91,61	97	-	70	32	25	7	1610	6F	0,90	70	45	25	20	1610	6F	1,30
24 H .. FMA	24	F34	97,02	95,65	102	-	74	32	25	7	1610	6F	1,00	74	45	25	20	1610	6F	1,00
25 H .. FMA	25	F35	101,06	99,69	106	-	77	32	25	7	1610	6F	1,00	77	45	25	20	1610	6F	1,20
26 H .. FMA	26	F36	105,11	103,73	112	-	82	32	25	7	1610	6F	1,20	82	45	25	20	1610	6F	1,40
27 H .. FMA	27	F37	109,15	107,78	115	-	85	32	25	7	1610	6F	1,30	85	45	25	20	1610	6F	1,60
28 H .. FMA	28	F38	113,19	111,82	120	-	90	32	25	7	1610	6F	1,50	90	45	25	20	1610	6F	1,80
30 H .. FMA	30	F40	121,28	119,90	128	-	98	32	25	7	1610	6F	1,70	98	45	25	20	1610	6F	2,30
32 H .. FMA	32	F42	129,36	127,99	135	80	106	32	25	7	1610	6AF	2,00	106	45	25	20	1610	6AF	2,30
36 H .. FMA	36	F48	145,53	144,16	150	92	121	32	25	7	1610	6AF	2,70	121	45	25	20	1610	6AF	3,10
40 H .. FMA	40	F52	161,70	160,33	168	92	138	32	25	7	1610	6AF	3,60	138	45	25	20	1610	6AF	4,00
44 H .. FMA	44	F55	177,87	176,50	184	106	152	32	32	-	2012	4EF	3,80	152	45	32	13	2012	6AF	4,40
48 H .. FMA	48	F59	194,04	192,67	200	106	169	32	32	-	2012	4EF	3,20	169	45	32	13	2012	6AF	4,80
60 H .. MA	60	-	242,55	241,18	-	92	223	34	32	1	2012	9E	4,80	223	46	32	7,5	2012	9E	5,40
72 H .. MA	72	-	291,06	289,69	-	92	270	34	32	1	2012	9E	5,70	270	46	32	7,5	2012	9E	6,50
84 H .. MA	84	-	339,57	338,20	-	92	318	34	32	1	2012	9E	6,80	318	46	32	7,5	2012	9E	8,40
96 H .. MA	96	-	388,08	386,71	-	106	366	34	45	5,5	2517	7E	8,20	366	46	45	0,5	2517	9E	11,00
120 H .. MA	120	-	485,10	483,73	-	106	462	34	45	5,5	2517	7E	12,10	462	46	45	0,5	2517	9E	14,80

.. Riemenbreite in 1/100 Inch d.h. 100 oder 150



ZAHNRIEMENSCHLEIBEN FÜR KLEMMBUCHSEN H200 - H300

TEILUNG: 1/2" (12,7 mm)
 MATERIAL:
 Stahl C40 UNI 7845
 Guss EN-GJL-250 UNI EN 1561

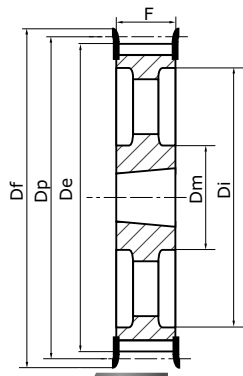
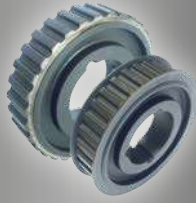

Typ 4EF
Hohl-Riemenschleibe

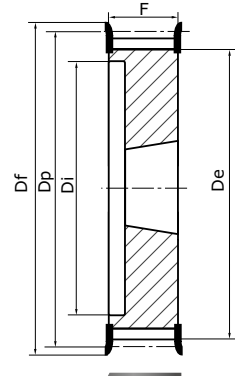

Typ 6F
Vollschleibe mit Bordschleiben

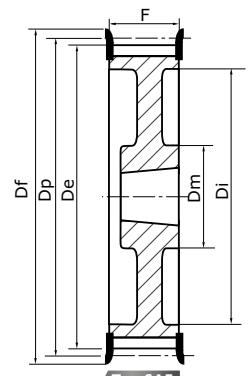

Typ 6AF
leichtere Riemenschleibe

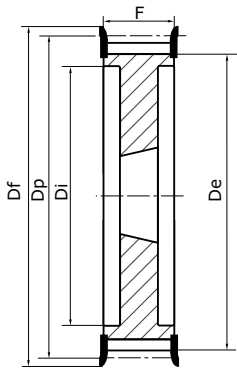

Typ 5F
Vollschleibe mit Bordschleiben

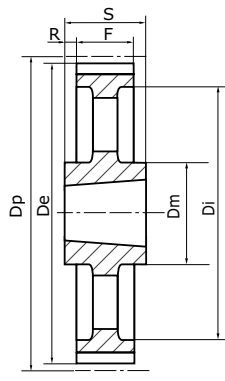

Typ 7E
Hohl-Riemenschleibe

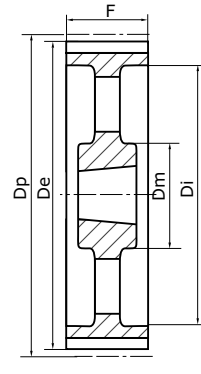

Typ 9E
Hohl-Riemenschleibe

Stahl = Z18 bis Z48
 Guss = Z60 bis Z120

Art. Nr.	Z	Flansch	Dp	De	Df	H200 für 50,8-Riemen						H300 für 76,2-Riemen													
						Dm	Di	F	S	R	Buchse	Typ	Kg	Dm	Di	F	S	R	Buchse	Typ	Kg				
18 H .. FMA	18	F28	72,77	71,39	79	-	52	58	25	33	1210	6F	0,80	-	-	-	-	-	-	-	-	-	-	-	-
19 H .. FMA	19	F29	76,81	75,44	83	-	56	58	25	33	1210	6F	0,90	-	-	-	-	-	-	-	-	-	-	-	-
20 H .. FMA	20	F30	80,85	79,48	87	-	60	58	25	33	1610	6F	1,00	-	65	84	38	23	1615	5F	1,50	-	-	-	-
21 H .. FMA	21	F31	84,89	83,52	91	-	64	58	25	33	1610	6F	1,70	-	65	84	38	23	1615	5F	1,20	-	-	-	-
22 H .. FMA	22	F32	88,94	87,56	93	-	67	58	25	33	1610	6F	1,50	-	67	84	38	23	1615	5F	1,60	-	-	-	-
23 H .. FMA	23	F33	92,98	91,61	97	-	70	58	25	33	1610	6F	1,80	-	70	84	38	23	1615	5F	1,80	-	-	-	-
24 H .. FMA	24	F34	97,02	95,65	102	-	74	58	25	33	1610	6F	1,50	-	74	84	38	23	1615	5F	2,00	-	-	-	-
25 H .. FMA	25	F35	101,06	99,69	106	-	77	58	25	33	1610	6F	1,50	-	77	84	38	23	1615	5F	2,00	-	-	-	-
26 H .. FMA	26	F36	105,11	103,73	112	-	82	58	25	33	1610	6F	1,80	-	82	84	38	23	1615	5F	2,70	-	-	-	-
27 H .. FMA	27	F37	109,15	107,78	115	-	85	58	25	33	1610	6F	1,90	-	85	84	32	26	2012	5F	3,00	-	-	-	-
28 H .. FMA	28	F38	113,19	111,82	120	-	90	58	25	33	1610	6F	1,90	-	90	84	32	26	2012	5F	2,40	-	-	-	-
30 H .. FMA	30	F40	121,28	119,90	128	-	98	58	25	33	1610	6F	2,30	-	98	84	32	26	2012	5F	2,90	-	-	-	-
32 H .. FMA	32	F42	129,36	127,99	135	-	106	58	32	26	2012	6F	3,00	-	106	84	45	19,05	2517	5F	3,30	-	-	-	-
36 H .. FMA	36	F48	145,53	144,16	150	102	121	58	32	26	2012	6AF	3,00	-	121	84	45	19,05	2517	5AF	4,50	-	-	-	-
40 H .. FMA	40	F52	161,70	160,33	168	106	140	58	32	26	2012	6AF	3,60	-	138	84	45	19,05	2517	5AF	6,00	-	-	-	-
44 H .. FMA	44	F55	177,87	176,50	184	106	150	58	32	26	2012	6AF	4,00	119	150	86	45	20,5	2517	5AF	6,60	-	-	-	-
48 H .. FMA	48	F59	194,04	192,67	200	119	168	58	45	13	2517	6AF	4,60	119	168	86	45	20,5	2517	5AF	7,60	-	-	-	-
60 H .. MA	60	-	242,55	241,18	-	119	223	60	45	7,5	2517	9E	7,00	119	223	86	45	20,5	2517	9E	8,40	-	-	-	-
72 H .. MA	72	-	291,06	289,69	-	119	270	60	45	7,5	2517	9E	8,00	119	270	86	45	20,5	2517	9E	10,40	-	-	-	-
84 H .. MA	84	-	339,57	338,20	-	119	318	60	45	7,5	2517	9E	9,00	119	318	86	45	20,5	2517	9E	12,50	-	-	-	-
96 H .. MA	96	-	388,08	386,71	-	119	366	60	45	7,5	2517	9E	10,00	150	366	86	76	5	3030	9E	14,20	-	-	-	-
120 H .. MA	120	-	485,10	483,73	-	119	462	60	45	7,5	2517	9E	13,40	150	462	86	76	5	3030	9E	18,80	-	-	-	-

.. Riemenbreite in 1/100 Inch d.h. 200 oder 300



ZAHNRIEMENSCHLEIBE FÜR KLEMMBUCHSEN „HTD“ 5M

TEILUNG: 5 mm
MATERIAL:
Stahl C40 UNI 7845

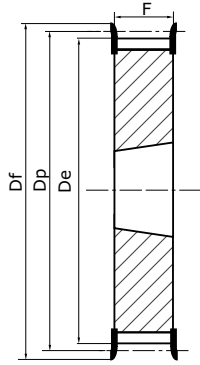
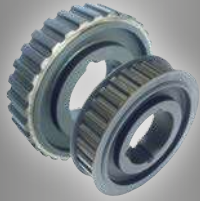

Typ 4F
Vollscheibe mit Bordscheiben

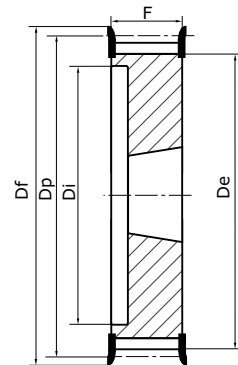

Typ 6F
Vollscheibe mit Bordscheiben

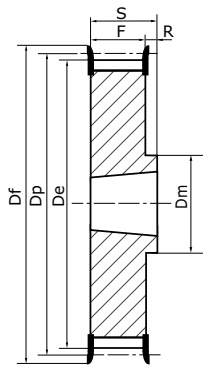

Typ 8F
Vollscheibe mit Bordscheiben

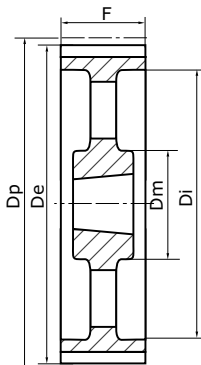

Typ 9E
Hohl-Riemenscheibe

5M-15
für 15 mm-Riemen

Art. Nr.	Z	Flansch	Dp	De	Df	Dm	Di	F	S	R	Buchse	Typ	Kg
34 5M 15 FMA	34	F21	54,11	52,97	57	-	-	22	22	-	1008	4F	0,40
36 5M 15 FMA	36	F22	57,30	56,15	60	-	-	22	22	-	1108	4F	0,43
38 5M 15 FMA	38	F25	60,48	59,34	66	-	-	22	22	-	1108	4F	0,45
40 5M 15 FMA	40	F26	63,66	62,52	70	-	-	22	22	-	1108	4F	0,52
44 5M 15 FMA	44	F27	70,03	68,89	75	-	-	22	22	-	1108	4F	0,62
48 5M 15 FMA	48	F29	76,39	75,25	93	59	-	22	25	3	1210	8F	0,19
56 5M 15 FMA	56	F32	89,13	87,39	94	70	-	22	25	3	1210	8F	0,22
64 5M 15 FMA	64	F25	101,86	100,72	106	80	-	22	25	3	1210	8F	0,25
72 5M 15 MA	72	-	114,59	113,45	-	92	-	22	25	3	1610	6F	0,30
80 5M 15 MA	80	-	127,32	126,18	-	92	-	22	25	3	1610	6F	0,33
90 5M 15 MA	90	-	143,24	142,10	-	92	-	22	25	3	1610	6F	0,37
112 5M 15 MA	112	-	178,25	177,11	-	110	-	20	32	12	2012	6F	0,46
136 5M 15 MA	136	-	216,45	215,31	-	110	199	20	32	6	2012	9E	0,56



ZAHNRIEMENSCHLEIBE FÜR KLEMMBUCHSEN „HTD“ 8M

TEILUNG: 8 mm
MATERIAL:
 Stahl C40 UNI 7845
 Guss EN-GJL-250 UNI EN 1561

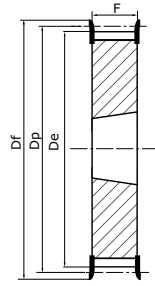
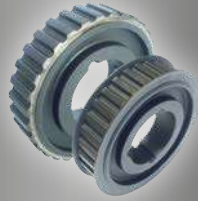

Typ 4F
Vollscheibe mit Bordscheiben

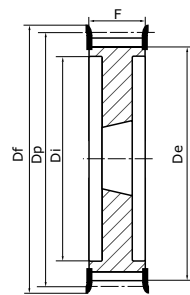

Typ 5F
Vollscheibe mit Bordscheiben

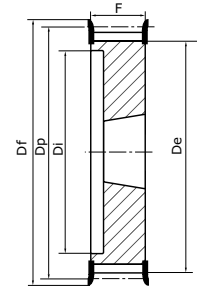

Typ 6F
Vollscheibe mit Bordscheiben

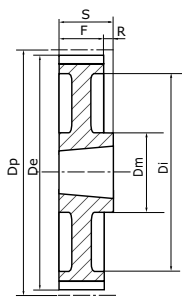

Typ 8A
leichtere Riemenscheibe

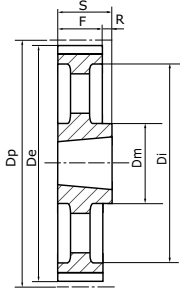

Typ 8E
Hohl-Riemenscheibe

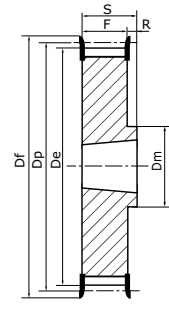

Typ 8F
Vollscheibe mit Bordscheiben

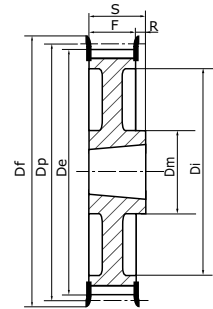

Typ 8AF
leichtere Riemenscheibe

Stahl = Z22 bis Z 72
Guss = Z80 bis Z144

Art. Nr.	Z	Flansch	Dp	De	Df	8M-20 für 20 mm-Riemen						8M-30 für 30 mm-Riemen									
						Dm	Di	F	S	R	Buchse	Typ	Kg	Dm	Di	F	S	R	Buchse	Typ	Kg
22 8M .. FMA	22	F22	56,02	54,65	60	-	37	28	22	6	1108	6F	0,25	-	37	38	22	16	1108	6F	0,31
24 8M .. FMA	24	F25	61,12	59,75	66	-	44	28	22	6	1108	6F	0,30	-	44	38	22	16	1108	6F	0,38
26 8M .. FMA	26	F26	66,21	64,84	70	-	45	28	22	6	1108	6F	0,36	-	44	38	22	16	1108	6F	0,45
28 8M .. FMA	28	F27	71,30	70,08	75	-	50	28	22	6	1108	6F	0,44	-	50	38	25	13	1210	6F	0,50
30 8M .. FMA	30	F29	76,39	75,13	83	-	58	28	22	6	1108	6F	0,53	-	-	38	38	-	1615	4F	0,55
32 8M .. FMA	32	F30	81,49	80,16	87	-	63	28	25	3	1610	6F	0,42	-	-	38	38	-	1615	4F	0,59
34 8M .. FMA	34	F31	86,58	85,22	91	-	64	28	25	3	1610	6F	0,55	-	-	38	38	-	1615	4F	0,77
36 8M .. FMA	36	F33	91,67	90,30	97	-	68	28	25	3	1610	6F	0,68	-	-	38	38	-	1615	4F	0,96
38 8M .. FMA	38	F34	96,77	95,39	102	-	72	28	25	3	1610	6F	0,80	-	-	38	38	-	1615	4F	1,15
40 8M .. FMA	40	F35	101,86	100,49	106	-	76	28	25	3	1610	6F	1,00	-	-	38	38	-	1615	4F	1,34
44 8M .. FMA	44	F38	112,05	110,67	120	93	-	28	32	4	2012	6F	1,20	-	86	38	32	3	2012	5F	1,33
48 8M .. FMA	48	F40	122,23	120,86	128	96	-	28	32	4	2012	8F	1,60	-	90	38	32	3	2012	5F	1,78
56 8M .. FMA	56	F48	142,60	141,23	150	110	-	28	32	4	2012	8F	2,40	-	110	38	32	3	2012	5F	3,76
64 8M.. FMA	64	F52	162,97	161,60	168	110	137	28	32	4	2012	8AF	2,70	125	-	38	45	7	2517	8F	4,20
72 8M .. FMA	72	F57	183,35	181,97	192	110	158	28	32	4	2012	8AF	3,30	125	158	38	45	7	2517	8AF	4,30
80 8M .. MA	80	-	203,72	202,35	-	110	180	28	32	4	2012	8AF	3,50	125	180	38	45	7	2517	8E	4,60
90 8M .. MA	90	-	229,18	227,81	-	110	204	28	32	4	2012	8A	3,65	125	204	38	45	7	2517	8A	5,00
112 8M .. MA	112	-	285,21	283,33	-	-	-	-	-	-	-	-	-	125	254	38	45	7	2517	8A	6,20
144 8M .. MA	144	-	366,69	265,32	-	125	336	28	32	4	2517	8A	4,80	125	336	38	45	7	2517	8A	9,00

.. Riemenbreite in mm d.h. 20, 30, 50 oder 85



ZAHNRIEMENSCHLEIBE FÜR KLEMMBUCHSEN „HTD“ 8M

TEILUNG: 8 mm
 MATERIAL:
 Stahl C40 UNI 7845
 Guss EN-GJL-250 UNI EN 1561

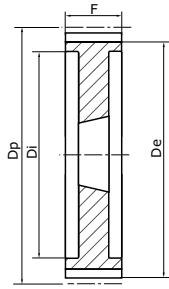
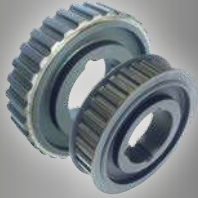

Typ 5
Vollscheibe

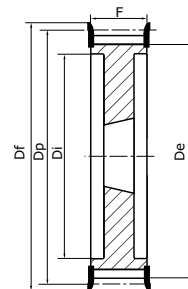

Typ 5F
Vollscheibe mit Bordscheiben

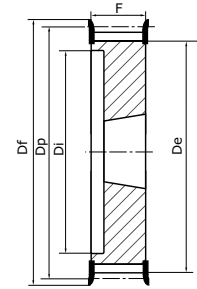

Typ 6F
Vollscheibe mit Bordscheiben

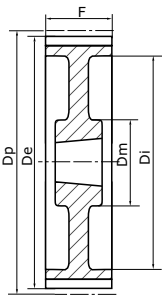

Typ 9A
leichtere Riemenscheibe

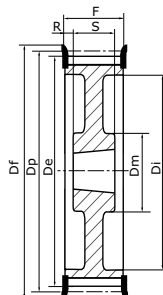

Typ 9AF
leichtere Riemenscheibe

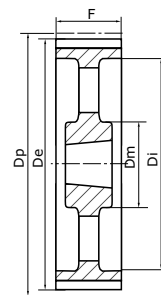

Typ 9E
Hohl-Riemenscheibe

Stahl = Z28 bis Z72
 Guss = Z80 bis Z192

Art. Nr.	Z	Flansch	Dp	De	Df	8M-50 für 50 mm-Riemen							8M-85 für 85 mm-Riemen													
						Dm	Di	F	S	R	Buchse	Typ	Kg	Dm	Di	F	S	R	Buchse	Typ	Kg					
28 8M .. FMA	28	F27	71,30	70,08	75	-	50	60	25	17,5	1210	5F	0,60	-	-	-	-	-	-	-	-	-	-	-	-	-
30 8M .. FMA	30	F29	76,39	75,13	83	-	58	60	38	22	1615	6F	0,65	-	-	-	-	-	-	-	-	-	-	-	-	-
32 8M .. FMA	32	F30	81,49	80,16	87	-	62	60	38	22	1615	6F	0,82	-	-	-	-	-	-	-	-	-	-	-	-	-
34 8M .. FMA	34	F31	86,58	85,22	91	-	65	60	38	22	1615	6F	1,06	-	65	95	38	28,5	1615	5F	1,43	-	-	-	-	-
36 8M .. FMA	36	F33	91,67	90,30	97	-	68	60	38	22	1615	6F	1,30	-	68	95	38	28,5	1615	5F	1,87	-	-	-	-	-
38 8M .. FMA	38	F34	96,77	95,39	102	-	72	60	38	22	1615	6F	1,60	-	72	95	38	28,5	1615	5F	2,20	-	-	-	-	-
40 8M .. FMA	40	F35	101,86	100,49	106	-	82	60	32	14	2012	5F	1,71	-	82	95	32	31,5	2012	5F	1,80	-	-	-	-	-
44 8M .. FMA	44	F38	112,05	110,67	120	-	91	60	32	14	2012	5F	1,78	-	91	95	32	31,5	2012	5F	2,30	-	-	-	-	-
48 8M .. FMA	48	F40	122,23	120,86	128	-	95	60	32	14	2012	5F	2,30	-	100	95	45	25	2517	5F	2,66	-	-	-	-	-
56 8M .. FMA	56	F48	142,60	141,23	150	-	116	60	45	7,5	2517	5F	3,40	-	117	95	45	25	2517	5F	4,45	-	-	-	-	-
64 8M .. FMA	64	F52	162,97	161,60	168	-	137	60	45	7,5	2517	5F	5,00	-	137	95	45	25	2517	5F	6,20	-	-	-	-	-
72 8M .. FMA	72	F57	183,35	181,97	192	125	158	60	45	7,5	2517	9AF	6,70	-	158	95	51	22	3020	5F	8,00	-	-	-	-	-
80 8M .. MA	80	-	203,72	202,35	-	-	180	60	51	4,5	3020	5	8,80	-	180	95	51	22	3020	5	10,00	-	-	-	-	-
90 8M .. MA	90	-	229,18	227,81	-	170	204	60	51	4,5	3020	9A	10,00	170	204	95	51	22	3020	9A	10,80	-	-	-	-	-
112 8M .. MA	112	-	285,21	283,83	-	170	260	60	51	4,5	3020	9A	12,00	170	260	95	51	22	3020	9A	15,00	-	-	-	-	-
144 8M .. MA	144	-	366,69	365,32	-	170	341	60	51	4,5	3020	9E	15,20	198	336	95	65	15	3525	9E	20,00	-	-	-	-	-
168 8M .. MA	168	-	427,81	426,44	-	198	402	60	65	2,5	3525	9E	17,50	198	395	95	65	15	3525	9E	22,00	-	-	-	-	-
192 8M .. MA	192	-	488,92	487,55	-	198	460	60	65	2,5	3525	9E	24,00	198	455	95	65	15	3525	9E	26,00	-	-	-	-	-

.. Riemenbreite in mm d.h. 20, 30, 50 oder 85



ZAHNRIEMENSCHLEIBE FÜR KLEMMBUCHSEN „HTD“ 14M

TEILUNG: 14 mm
 MATERIAL:
 Stahl C40 UNI 7845
 Guss EN-GJL-250 UNI EN 1561

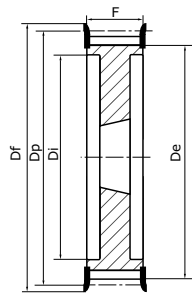
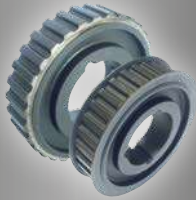

Typ 5F

Vollscheibe mit Bordscheiben

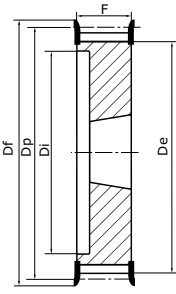

Typ 6F

Vollscheibe mit Bordscheiben

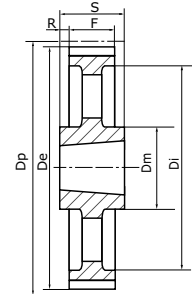

Typ 7E

Hohl-Riemenscheibe

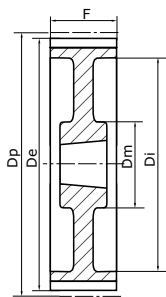

Typ 9A

leichtere Riemenscheibe

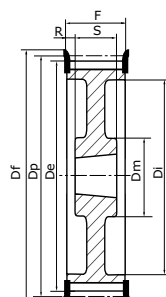

Typ 9AF

leichtere Riemenscheibe

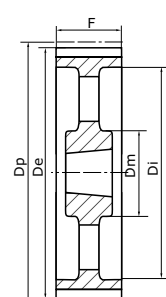

Typ 9E

Hohl-Riemenscheibe

Stahl = Z28 bis Z56
 Guss = Z64 bis Z216

Art. Nr.	Z	Flansch	Dp	De	Df	Di	14M-40 für 40 mm-Riemen						14M-55 für 55 mm-Riemen							
							Dm	F	S	R	Buchse	Typ	Kg	Dm	F	S	R	Buchse	Typ	Kg
28 14M .. FMA	28	F40	124,78	122,12	128	94	-	54	32	11	2012	5F	2,07	-	70	32	19	2012	5F	2,20
29 14M .. FMA	29	F43	129,23	126,57	138	98	-	54	32	11	2012	5F	2,38	-	70	32	19	2012	5F	2,74
30 14M .. FMA	30	F43	133,69	130,99	138	98	-	54	32	11	2012	5F	2,65	-	70	45	12,5	2517	6F	2,70
32 14M .. FMA	32	F49	142,60	139,88	154	108	-	54	32	11	2012	5F	3,40	-	70	45	12,5	2517	6F	3,66
34 14M .. FMA	34	F51	151,52	148,79	160	110	-	54	45	4,5	2517	5F	3,87	-	70	45	12,5	2517	6F	4,55
36 14M .. FMA	36	F52	160,43	157,68	168	120	-	54	45	4,5	2517	5F	4,80	-	70	45	12,5	2517	6F	5,20
38 14M .. FMA	38	F81	169,34	166,60	184	130	-	54	45	4,5	2517	5F	5,40	-	70	45	12,5	2517	6F	6,20
40 14M .. FMA	40	F56	178,25	175,49	188	138	-	54	45	4,5	2517	5F	6,00	-	70	45	12,5	2517	5F	7,00
44 14M .. FMA	44	F61	196,08	193,28	212	155	-	54	51	1,5	3020	5F	7,80	-	70	51	9,5	3020	5F	8,60
48 14M .. FMA	48	F62	213,90	211,11	226	170	-	54	51	1,5	3020	5F	9,40	-	70	51	9,5	3020	5F	10,40
56 14M .. FMA	56	F66	249,55	246,76	256	208	170	54	51	1,5	3020	9AF	10,80	170	70	51	9,5	3020	9AF	12,40
64 14M .. FMA	64	F70	285,21	282,41	296	240	170	54	51	1,5	3020	9AF	13,40	170	70	51	9,5	3020	9AF	14,50
72 14M .. MA	72	-	320,86	318,06	-	280	170	54	51	1,5	3020	9A	15,20	170	70	51	9,5	3020	9A	16,20
80 14M .. MA	80	-	356,51	353,71	-	315	170	54	51	1,5	3020	9E	16,00	170	70	51	9,5	3020	9E	17,50
90 14M .. MA	90	-	401,07	398,28	-	360	170	54	51	1,5	3020	9E	17,80	170	70	51	9,5	3020	9E	20,10
112 14M .. MA	112	-	499,11	496,32	-	457	170	54	51	1,5	3020	9E	25,60	170	70	51	9,5	3020	9E	28,40
144 14M .. MA	144	-	641,71	638,92	-	600	170	54	51	1,5	3020	9E	32,00	170	70	51	9,5	3020	9E	36,20
168 14M .. MA	168	-	748,66	745,87	-	706	170	54	51	1,5	3020	9E	44,00	170	70	51	9,5	3020	9E	49,00
192 14M .. MA	192	-	855,62	852,82	-	813	170	54	51	1,5	3020	9E	49,00	170	70	51	9,5	3020	9E	53,00
216 14M .. MA	216	-	962,57	959,76	-	920	170	54	51	1,5	3020	9E	55,00	170	70	89	9,5	3535	7E	65,80

.. Riemenbreite in mm d.h. 40, 55, 85 oder 115

ZAHNRIEMENSCHLEIBE FÜR KLEMMBUCHSEN „HTD“ 14M

TEILUNG: 14 mm
MATERIAL:
 Stahl C40 UNI 7845
 Guss EN-GJL-250 UNI EN 1561

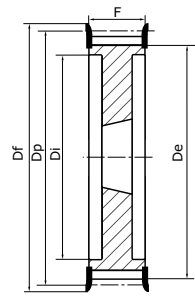
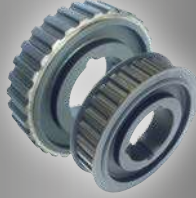
Typ 5F

Vollscheibe mit Bordscheiben

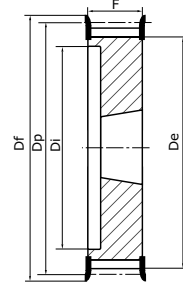
Typ 6F

Vollscheibe mit Bordscheiben

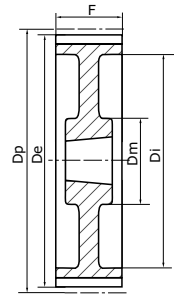
Typ 9A

leichtere Riemenscheibe

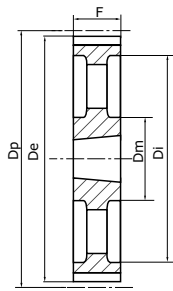
Typ 4E

Hohl-Riemenscheibe

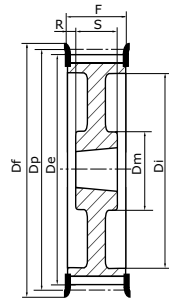
Typ 9AF

leichtere Riemenscheibe

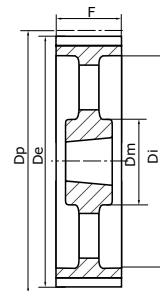
Typ 9E

Hohl-Riemenscheibe

Stahl = Z28 bis Z56
Guss = Z64 bis Z216

Art. Nr.	Z	Flansch	Dp	De	Df	Di	14M-85 für 85 mm-Riemen							14M-115 für 115 mm-Riemen						
							Dm	F	S	R	Buchse	Typ	Kg	Dm	F	S	R	Buchse	Typ	Kg
28 14M .. FMA	28	F40	124,78	122,12	128	98	-	102	45	28,5	2517	5F	2,70	-	133	45	44	2517	5F	3,77
29 14M .. FMA	29	F43	129,23	126,57	138	100	-	102	45	28,5	2517	6F	3,40	-	133	45	44	2517	5F	4,00
30 14M .. FMA	30	F43	133,69	130,99	138	100	-	102	45	28,5	2517	6F	3,75	-	133	45	44	2517	5F	5,00
32 14M .. FMA	32	F49	142,60	139,88	154	108	-	102	45	28,5	2517	6F	4,80	-	133	45	44	2517	5F	6,80
34 14M .. FMA	34	F51	151,52	148,79	160	110	-	102	45	28,5	2517	6F	6,00	-	133	45	44	2517	5F	6,80
36 14M .. FMA	36	F52	160,43	157,68	168	120	-	102	51	25,5	3020	6F	5,80	-	133	51	41	3020	5F	7,00
38 14M .. FMA	38	F81	169,34	166,60	184	130	-	102	51	25,5	3020	6F	6,80	-	133	51	41	3020	5F	8,40
40 14M .. FMA	40	F56	178,25	175,49	188	138	-	102	51	25,5	3020	5F	8,00	-	133	51	41	3020	5F	9,20
44 14M .. FMA	44	F61	196,08	193,28	212	153	-	102	51	25,5	3020	5F	11,80	-	133	76	28,5	3030	5F	14,00
48 14M .. FMA	48	F62	213,90	211,11	226	170	-	102	51	25,5	3020	5F	15,10	-	133	76	28,5	3030	5F	17,10
56 14M .. FMA	56	F66	249,55	246,76	256	220	190	102	65	18,5	3525	5F	19,00	-	133	89	22	3535	5F	24,80
64 14M .. FMA	64	F70	285,21	282,41	296	240	190	102	65	18,5	3525	9AF	23,00	190	133	89	22	3535	9AF	27,00
72 14M .. MA	72	-	320,86	318,06	-	280	190	102	65	18,5	3525	9A	25,00	190	133	89	22	3535	9A	29,00
80 14M .. MA	80	-	356,51	353,71	-	315	190	102	65	18,5	3525	9E	26,00	190	133	89	22	3535	9E	32,00
90 14M .. MA	90	-	401,07	398,28	-	360	190	102	65	18,5	3525	9E	27,80	190	133	89	22	3535	9E	36,50
112 14M MA	112	-	499,11	496,32	-	457	190	102	65	18,5	3525	9E	36,50	190	133	89	22	3535	9E	46,00
144 14M .. MA	144	-	641,71	638,92	-	600	190	102	65	18,5	3525	9E	48,00	230	133	102	15,5	4040	9E	68,00
168 14M .. MA	168	-	748,66	745,87	-	706	190	102	65	18,5	3525	9E	60,00	230	133	102	15,5	4040	9E	82,60
192 14M .. MA	192	-	855,62	852,82	-	813	190	102	102	-	4040	4E	86,00	230	133	102	15,5	4040	9E	96,00
216 14M .. MA	216	-	962,57	959,76	-	920	190	102	102	-	4040	4E	91,50	230	133	102	15,5	4040	9E	107,00

.. Riemenbreite in mm d.h. 40, 55, 85 oder 115



ZAHNRIEMENSCHLEIBE FÜR KLEMMBUCHSEN „HTD“ 14M

TEILUNG: 14 mm
MATERIAL:
 Stahl C40 UNI 7845
 Guss EN-GJL-250 UNI EN 1561

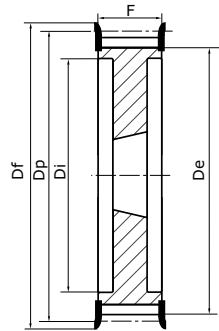
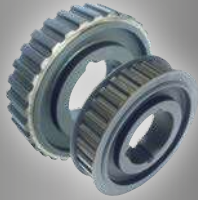

Typ 5F
 Vollscheibe mit Bordscheiben

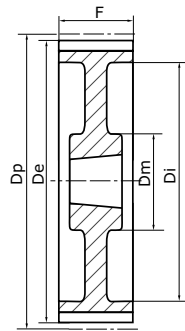

Typ 9A
 leichtere Riemenscheibe

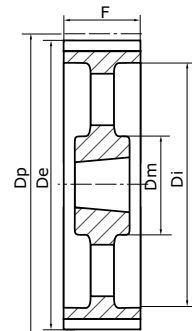

Typ 9E
 Hohl-Riemenscheibe

Stahl = Z38 bis Z56
Guss = Z64 bis Z216

14M-170
 für 170 mm-Riemen

Art. Nr.	Z	Flansch	Dp	De	Df	Di	Dm	F	S	R	Buchse	Typ	Kg
38 14M 170 FMA	38	F81	169,34	166,60	184	130	-	187	76	55,5	3030	5F	11,70
40 14M 170 FMA	40	F56	178,25	175,49	188	138	-	187	76	55,5	3030	5F	13,00
44 14M 170 FMA	44	F61	196,08	193,28	212	153	-	187	89	49	3535	5F	15,00
48 14M 170 FMA	48	F62	213,90	211,11	226	170	-	187	89	49	3535	5F	19,00
56 14M 170 FMA	56	F66	249,55	246,76	256	208	-	187	89	49	3535	5F	28,50
64 14M 170 FMA	64	F70	285,21	282,41	296	240	-	187	102	42,5	4040	5F	41,00
72 14M 170 MA	72	-	320,86	318,06	-	280	230	187	102	42,5	4040	9A	46,90
80 14M 170 MA	80	-	356,51	353,71	-	315	230	187	102	42,5	4040	9A	48,00
90 14M 170 MA	90	-	401,07	398,28	-	360	230	187	102	42,5	4040	9E	52,50
112 14M 170 MA	112	-	499,11	496,32	-	457	265	187	127	30	5050	9E	74,50
144 14M 170 MA	144	-	641,71	638,92	-	600	265	187	127	30	5050	9E	91,00
168 14M 170 MA	168	-	748,66	745,87	-	706	265	187	127	30	5050	9E	116,00
192 14M 170 MA	192	-	855,62	852,82	-	813	265	187	127	30	5050	9E	134,00
216 14M 170 MA	216	-	962,57	959,76	-	920	265	187	127	30	5050	9E	146,50

sedis 

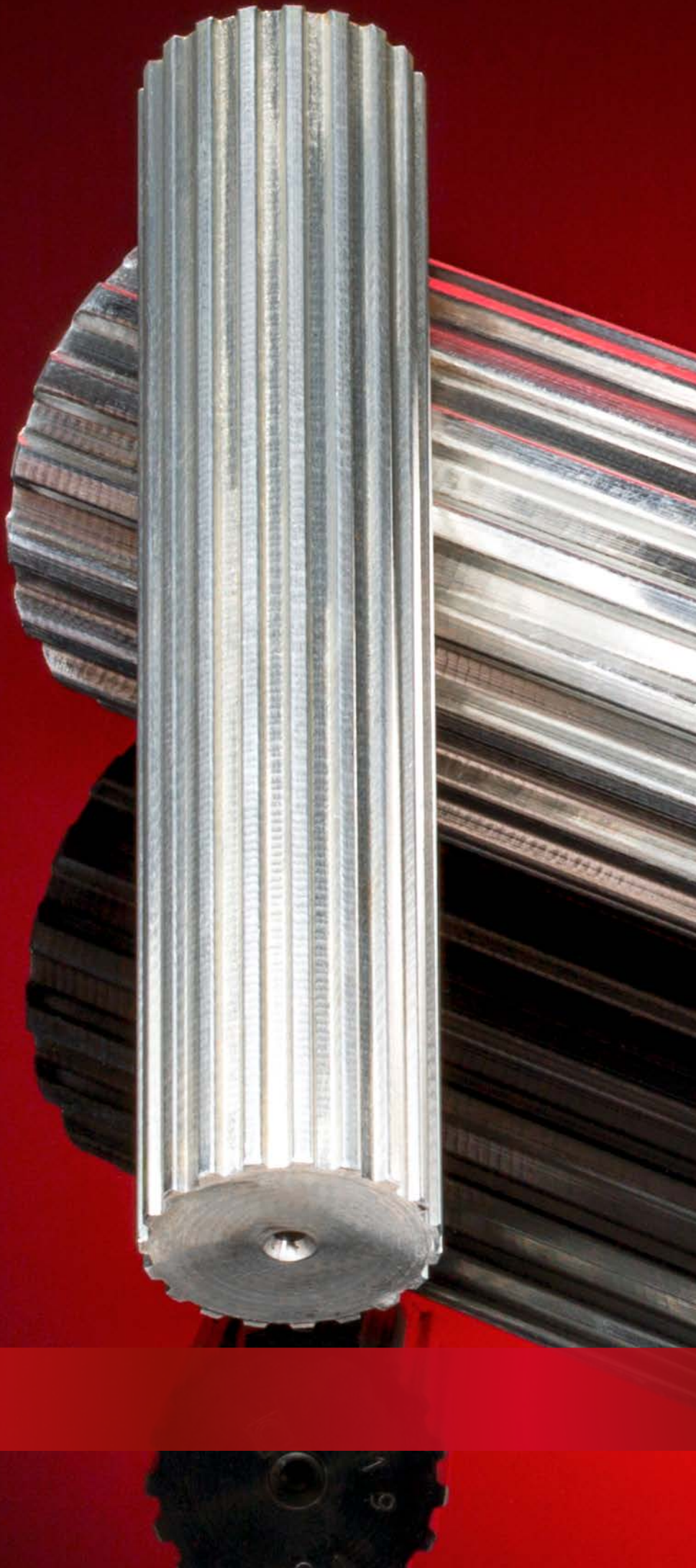

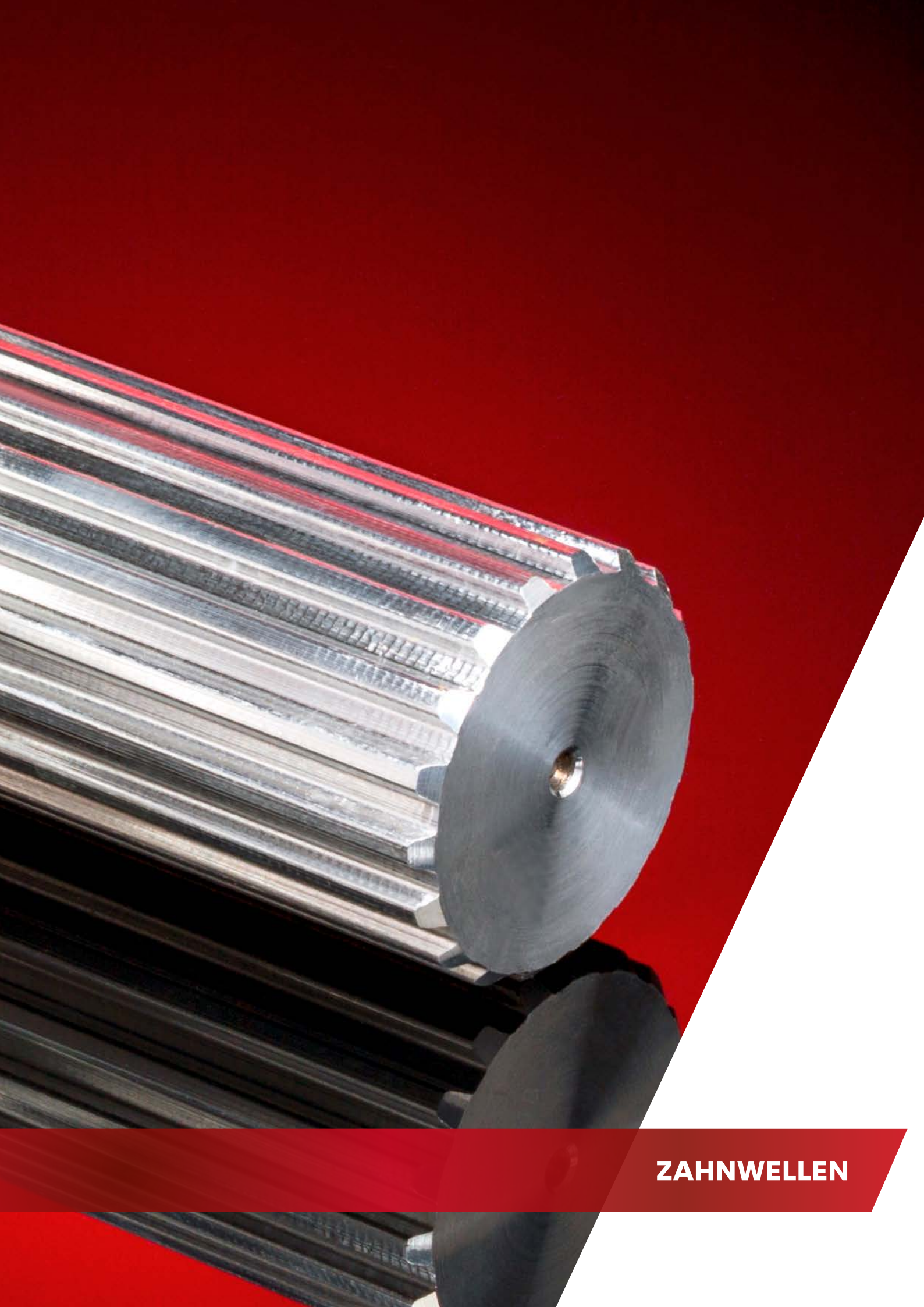

ZAHNWELLEN



ZAHNWELLEN ALUMINIUM - METRISCH

MATERIAL: Aluminium
6082T6 UNI 9006/4
Zum Eloxieren geeignet

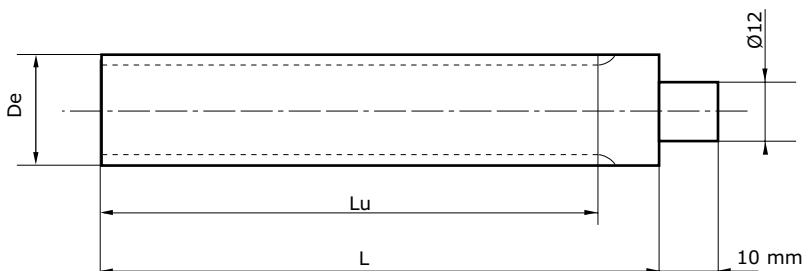
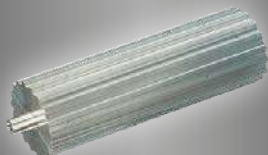

T2,5 - Teilung 2,5 mm					T5 - Teilung 5 mm					T10 - Teilung 10 mm				
Art. Nr.	Z	De	Lu	L	Art. Nr.	Z	De	Lu	L	Art. Nr.	Z	De	Lu	L
10 T2,5	10	7,42	50	75	10 T5	10	15,05	125	140	10 T10	10	29,98	140	140
12 T2,5	12	9,00	50	75	11 T5	11	16,65	125	140	11 T10	11	33,16	140	140
13 T2,5	13	9,80	50	75	12 T5	12	18,25	125	140	12 T10	12	36,35	140	140
14 T2,5	14	10,60	50	75	13 T5	13	19,85	125	140	13 T10	13	39,50	140	140
15 T2,5	15	11,40	50	75	14 T5	14	21,45	132	140	14 T10	14	42,70	160	160
16 T2,5	16	12,20	50	75	15 T5	15	23,05	132	140	15 T10	15	45,90	160	160
17 T2,5	17	13,00	50	75	16 T5	16	24,60	140	140	16 T10	16	49,10	160	160
18 T2,5	18	13,80	50	75	17 T5	17	26,20	140	140	17 T10	17	52,25	160	160
19 T2,5	19	14,60	90	120	18 T5	18	27,80	140	140	18 T10	18	55,45	160	160
20 T2,5	20	15,40	90	120	19 T5	19	29,40	140	140	19 T10	19	58,60	160	160
21 T2,5	21	16,20	90	120	20 T5	20	31,00	160	160	20 T10	20	61,60	160	160
22 T2,5	22	17,00	125	140	21 T5	21	32,70	160	160	21 T10	21	65,00	160	160
24 T2,5	24	18,55	125	140	22 T5	22	34,15	160	160	22 T10	22	68,20	160	160
26 T2,5	26	20,15	125	140	23 T5	23	35,85	160	160	23 T10	23	71,35	160	160
27 T2,5	27	20,95	125	140	24 T5	24	37,40	160	160	24 T10	24	74,55	160	160
28 T2,5	28	21,75	125	140	25 T5	25	38,95	160	160	26 T10	26	80,90	160	160
29 T2,5	29	22,55	125	140	26 T5	26	40,60	160	160	28 T10	28	87,25	160	160
30 T2,5	30	23,35	125	140	27 T5	27	42,20	160	160	30 T10	30	93,65	160	160
32 T2,5	32	24,95	125	140	28 T5	28	43,75	160	160	32 T10	32	100,00	160	160
34 T2,5	34	26,55	125	140	29 T5	29	45,35	160	160	34 T10	34	106,40	160	160
35 T2,5	35	27,35	132	140	30 T5	30	46,95	160	160	36 T10	36	112,75	160	160
36 T2,5	36	28,10	132	140	32 T5	32	50,10	160	160	38 T10	38	119,10	160	160
38 T2,5	38	29,70	132	140	34 T5	34	53,25	160	160	40 T10	40	125,45	160	160
40 T2,5	40	31,30	132	140	35 T5	35	54,85	160	160	45 T10	45	141,40	160	160
42 T2,5	42	32,90	140	140	36 T5	36	56,45	160	160	48 T10	48	150,95	160	160
44 T2,5	44	34,50	140	140	37 T5	37	58,06	160	160	60 T10	60	189,10	160	160
45 T2,5	45	35,30	140	140	38 T5	38	59,65	160	160	72 T10	72	227,29	160	160
48 T2,5	48	37,70	140	140	40 T5	40	62,85	160	160					
50 T2,5	50	39,29	160	160	42 T5	42	66,00	160	160					
60 T2,5	60	47,25	160	160	44 T5	44	69,20	160	160					
65 T2,5	65	51,20	160	160	45 T5	45	70,80	160	160					
70 T2,5	70	55,20	160	160	46 T5	46	72,40	160	160					
72 T2,5	72	56,80	160	160	48 T5	48	75,55	160	160					
90 T2,5	90	71,12	160	160	50 T5	50	78,75	160	160					
100 T2,5	100	79,08	160	160	60 T5	60	94,65	160	160					
					72 T5	72	113,75	160	160					
					80 T5	80	126,48	160	160					
					90 T5	90	142,40	160	160					
					100 T5	100	158,31	160	160					

ZAHNWELLEN ALUMINIUM RIEMEN „AT“

MATERIAL: Aluminium
6082T6 UNI 9006/4
Zum Eloxieren geeignet

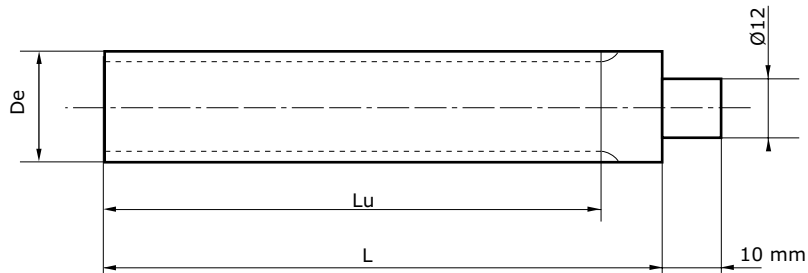

ST5 - Teilung 5 mm					ST10 - Teilung 10 mm				
Art. Nr.	Z	De	Lu	L	Art. Nr.	Z	De	Lu	L
12 ST5	12	17,85	125	140	15 ST10	15	45,90	160	160
13 ST5	13	19,45	125	140	16 ST10	16	49,05	160	160
14 ST5	14	21,05	132	140	17 ST10	17	52,25	160	160
15 ST5	15	22,65	132	140	18 ST10	18	55,45	160	160
16 ST5	16	24,20	140	140	19 ST10	19	58,60	160	160
17 ST5	17	25,80	140	140	20 ST10	20	61,80	160	160
18 ST5	18	27,40	140	140	21 ST10	21	65,00	160	160
19 ST5	19	29,00	140	140	22 ST10	22	68,15	160	160
20 ST5	20	30,60	160	160	23 ST10	23	71,35	160	160
21 ST5	21	32,30	160	160	24 ST10	24	74,55	160	160
22 ST5	22	33,85	160	160	25 ST10	25	77,70	160	160
23 ST5	23	35,45	160	160	26 ST10	26	80,90	160	160
24 ST5	24	37,00	160	160	27 ST10	27	84,10	160	160
25 ST5	25	38,60	160	160	28 ST10	28	87,25	160	160
26 ST5	26	40,20	160	160	29 ST10	29	90,45	160	160
27 ST5	27	41,80	160	160	30 ST10	30	93,65	160	160
28 ST5	28	43,35	160	160	31 ST10	31	96,80	160	160
29 ST5	29	44,95	160	160	32 ST10	32	100,00	160	160
30 ST5	30	46,55	160	160	33 ST10	33	103,20	160	160
31 ST5	31	48,15	160	160	34 ST10	34	106,40	160	160
32 ST5	32	49,70	160	160	35 ST10	35	109,55	160	160
33 ST5	33	51,30	160	160	36 ST10	36	112,75	160	160
34 ST5	34	52,85	160	160	37 ST10	37	115,90	160	160
35 ST5	35	54,45	160	160	38 ST10	38	119,10	160	160
36 ST5	36	56,05	160	160	40 ST10	40	125,45	160	160
38 ST5	38	59,25	160	160	41 ST10	41	128,65	160	160
40 ST5	40	62,45	160	160	42 ST10	42	131,85	160	160
42 ST5	42	65,60	160	160	44 ST10	44	138,20	160	160
44 ST5	44	68,80	160	160	45 ST10	45	141,40	160	160
45 ST5	45	70,40	160	160	46 ST10	46	144,55	160	160
46 ST5	46	72,00	160	160	48 ST10	48	150,95	160	160
48 ST5	48	75,15	160	160	50 ST10	50	157,30	160	160
50 ST5	50	78,35	160	160	51 ST10	51	160,50	160	160
52 ST5	52	81,55	160	160	52 ST10	52	163,65	160	160
54 ST5	54	84,70	160	160	54 ST10	54	170,05	160	160
55 ST5	55	86,30	160	160	55 ST10	55	173,20	160	160
56 ST5	56	87,90	160	160	56 ST10	56	176,40	160	160
58 ST5	58	91,10	160	160	57 ST10	57	179,60	160	160
60 ST5	60	94,25	160	160	58 ST10	58	182,75	160	160
62 ST5	62	97,45	160	160	52 ST10	52	163,65	160	160
64 ST5	64	100,65	160	160	59 ST10	59	185,75	160	160
65 ST5	65	102,25	160	160	60 ST10	60	189,10	160	160
72 ST5	72	113,25	160	160	62 ST10	62	195,50	160	160
					70 ST10	70	229,95	160	160
					75 ST10	75	236,90	160	160



ZAHNWELLEN - INCH

MATERIAL:

Aluminium 3571 TA16 UNI
Stahl C40 UNI 7845

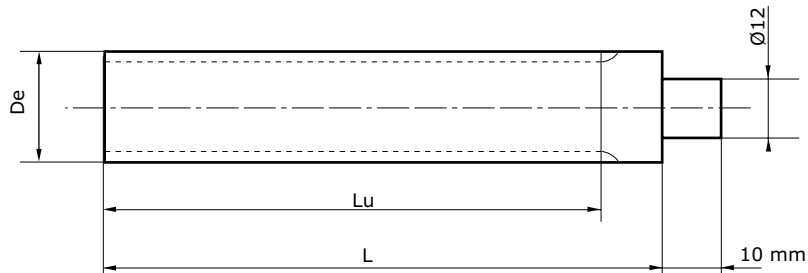

MXL 0,80" Teilung (Aluminium)					XL Teilung 1/5"					L Teilung 3/8"				
Art. Nr.	Z	De	Lu	L	Art. Nr.	Z	De	Lu	L	Art. Nr.	Z	De	Lu	L
10 MXL AL	10	5,97	50	75	10 XL..	10	15,66	125	140	10 L..	10	29,56	140	140
11 MXL AL	11	6,60	50	75	11 XL..	11	17,28	125	140	11 L..	11	32,59	140	140
12 MXL AL	12	7,26	50	75	12 XL..	12	18,90	125	140	12 L..	12	35,62	160	160
13 MXL AL	13	7,90	50	75	13 XL..	13	20,51	125	140	13 L..	13	38,65	160	160
14 MXL AL	14	8,56	50	75	14 XL..	14	22,13	132	140	14 L..	14	41,68	160	160
15 MXL AL	15	9,19	50	75	15 XL..	15	23,75	132	140	15 L..	15	44,72	160	160
16 MXL AL	16	9,83	50	75	16 XL..	16	25,36	140	140	16 L..	16	47,75	160	160
17 MXL AL	17	10,49	50	75	17 XL..	17	26,98	140	140	17 L..	17	50,78	160	160
18 MXL AL	18	11,12	50	75	18 XL..	18	28,60	140	140	18 L..	18	53,81	160	160
19 MXL AL	19	11,78	90	120	19 XL..	19	30,22	140	140	19 L..	19	56,84	160	160
20 MXL AL	20	12,42	90	120	20 XL..	20	31,83	140	140	20 L..	20	59,88	160	160
21 MXL AL	21	13,08	90	120	21 XL..	21	33,45	160	160	21 L..	21	62,91	160	160
22 MXL AL	22	13,72	125	140	22 XL..	22	35,07	160	160	22 L..	22	65,94	160	160
23 MXL AL	23	14,38	125	140	23 XL..	23	36,60	160	160	23 L..	23	68,97	160	160
24 MXL AL	24	15,01	125	140	24 XL..	24	38,30	160	160	24 L..	24	72,00	160	160
25 MXL AL	25	15,67	125	140	25 XL..	25	39,93	160	160	27 L..	27	81,10	160	160
26 MXL AL	26	16,31	125	140	26 XL..	26	41,53	160	160	30 L..	30	90,20	160	160
27 MXL AL	27	16,94	125	140	27 XL..	27	43,15	160	160	.. AL für Aluminium oder AC für Stahl				
28 MXL AL	28	16,70	125	140	28 XL..	28	44,77	160	160					
29 MXL AL	29	18,24	125	140	29 XL..	29	46,39	160	160					
30 MXL AL	30	18,90	125	140	30 XL..	30	48,00	160	160					
32 MXL AL	32	20,19	125	140	32 XL..	32	51,24	160	160					
34 MXL AL	34	21,49	125	140	33 XL..	33	52,76	160	160					
35 MXL AL	35	22,12	132	140	34 XL..	34	54,47	160	160					
36 MXL AL	36	22,78	132	140	35 XL..	35	56,09	160	160					
38 MXL AL	38	24,08	132	140	36 XL..	36	57,70	160	160					
40 MXL AL	40	25,37	132	140	38 XL..	38	60,94	160	160					
42 MXL AL	42	26,67	140	140	39 XL..	39	62,56	160	160					
44 MXL AL	44	27,94	140	140	40 XL..	40	64,17	160	160					
45 MXL AL	45	28,60	140	140	41 XL..	41	65,79	160	160					
48 MXL AL	48	30,53	140	140	42 XL..	42	67,41	160	160					
50 MXL AL	50	32,33	140	140	43 XL..	43	69,02	160	160					
60 MXL AL	60	38,30	160	160	44 XL..	44	70,64	160	160					
64 MXL AL	64	40,89	160	160	48 XL..	48	77,11	160	160					
65 MXL AL	65	41,53	160	160	56 XL..	56	90,04	160	160					
70 MXL AL	70	44,78	160	160	60 XL..	60	96,51	160	160					
72 MXL AL	72	46,05	160	160	72 XL..	72	115,92	160	160					
75 MXL AL	75	48,01	160	160										
90 MXL AL	90	57,71	160	160										
110 MXL AL	110	70,64	160	160										



ZAHNWELLEN TYP „HTD“

MATERIAL:

Aluminium UNI 3571 TA16

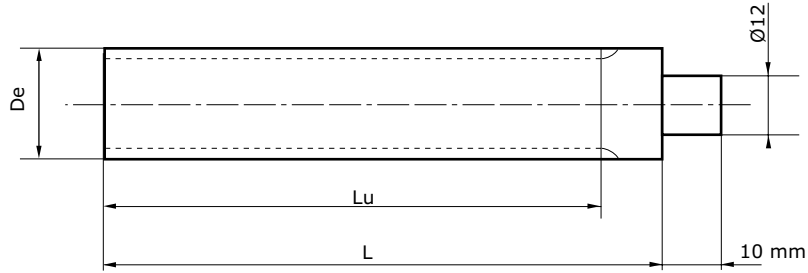

3M - Teilung 3 mm						5M - Teilung 5 mm					
Art. Nr.	Z	De	Dp	Lu	L	Art. Nr.	Z	De	Dp	Lu	L
9 HTD 3M	9	8,59	7,83	75	100	12 HTD 5M	12	19,10	17,96	150	165
10 HTD 3M	10	9,55	8,79	75	100	13 HTD 5M	13	20,69	19,55	150	165
11 HTD 3M	11	10,50	9,74	75	100	14 HTD 5M	14	22,28	21,14	175	183
12 HTD 3M	12	11,46	10,70	100	125	15 HTD 5M	15	23,87	22,73	175	183
13 HTD 3M	13	12,41	11,65	100	125	16 HTD 5M	16	25,46	24,32	175	183
14 HTD 3M	14	13,37	12,61	100	125	17 HTD 5M	17	27,06	25,92	175	183
15 HTD 3M	15	14,32	13,56	100	125	18 HTD 5M	18	28,65	27,51	200	200
16 HTD 3M	16	15,28	14,52	125	155	19 HTD 5M	19	30,24	29,10	200	200
17 HTD 3M	17	16,23	15,47	125	155	20 HTD 5M	20	31,83	30,69	200	200
18 HTD 3M	18	17,19	16,43	125	155	21 HTD 5M	21	33,42	32,28	200	200
19 HTD 3M	19	18,14	17,38	125	155	22 HTD 5M	22	35,01	33,87	200	200
20 HTD 3M	20	19,10	18,34	150	165	23 HTD 5M	23	36,61	35,47	200	200
21 HTD 3M	21	20,05	19,25	150	165	24 HTD 5M	24	38,20	37,06	200	200
22 HTD 3M	22	21,01	20,25	150	165	25 HTD 5M	25	39,79	38,65	200	200
23 HTD 3M	23	21,96	21,20	150	165	26 HTD 5M	26	41,38	40,24	200	200
24 HTD 3M	24	22,92	22,16	150	165	27 HTD 5M	27	42,97	41,83	200	200
25 HTD 3M	25	23,87	23,11	150	165	28 HTD 5M	28	44,56	43,42	200	200
26 HTD 3M	26	24,83	24,07	150	165	29 HTD 5M	29	46,15	45,01	200	200
27 HTD 3M	27	25,78	25,02	150	165	30 HTD 5M	30	47,75	46,60	200	200
28 HTD 3M	28	26,74	25,98	150	165	31 HTD 5M	31	49,34	48,20	200	200
29 HTD 3M	29	27,69	26,93	150	165	32 HTD 5M	32	50,93	49,79	200	200
30 HTD 3M	30	28,65	27,89	175	183	33 HTD 5M	33	52,52	51,38	200	200
31 HTD 3M	31	29,60	28,84	175	183	34 HTD 5M	34	54,11	52,97	200	200
32 HTD 3M	32	30,56	29,80	175	183	35 HTD 5M	35	55,70	54,56	200	200
33 HTD 3M	33	31,54	30,75	175	183	36 HTD 5M	36	57,30	56,16	200	200
34 HTD 3M	34	32,47	31,71	175	183	38 HTD 5M	38	60,48	59,34	200	200
35 HTD 3M	35	33,42	32,66	175	183	40 HTD 5M	40	63,66	62,52	200	200
36 HTD 3M	36	34,38	33,62	200	200	42 HTD 5M	42	66,85	65,71	200	200
37 HTD 3M	37	35,33	34,57	200	200	44 HTD 5M	44	70,03	68,89	200	200
38 HTD 3M	38	36,29	35,53	200	200	45 HTD 5M	45	71,62	70,48	200	200
39 HTD 3M	39	37,24	36,48	200	200	46 HTD 5M	46	73,21	72,07	200	200
40 HTD 3M	40	38,20	37,44	200	200	48 HTD 5M	48	76,39	75,25	200	200
42 HTD 3M	42	40,11	39,34	200	200	50 HTD 5M	50	79,58	78,43	200	200
44 HTD 3M	44	42,02	41,26	200	200	54 HTD 5M	54	85,94	84,80	200	200
45 HTD 3M	45	42,97	42,21	200	200	60 HTD 5M	60	95,49	94,35	200	200
48 HTD 3M	48	45,84	45,08	200	200	62 HTD 5M	62	98,68	97,54	200	200
50 HTD 3M	50	47,75	46,99	200	200	72 HTD 5M	72	114,59	113,45	200	200
52 HTD 3M	52	49,66	48,90	200	200						
54 HTD 3M	54	51,57	50,81	200	200						
56 HTD 3M	56	53,48	52,72	200	200						
60 HTD 3M	60	57,30	56,54	200	200						
62 HTD 3M	62	59,21	58,45	200	200						
64 HTD 3M	64	61,12	60,36	200	200						
66 HTD 3M	66	63,03	62,27	200	200						
68 HTD 3M	68	64,94	64,18	200	200						
70 HTD 3M	70	66,85	66,09	200	200						
72 HTD 3M	72	68,75	67,99	200	200						

MATERIAL:

Stahl



8M 8mm Teilung

Art. Nr.	Z	De	Lu	L
18 HTD 8M	18	44,47	200	200
19 HTD 8M	19	47,01	200	200
20 HTD 8M	20	49,56	200	200
21 HTD 8M	21	52,11	200	200
22 HTD 8M	22	54,65	200	200
23 HTD 8M	23	57,20	200	200
24 HTD 8M	24	59,75	200	200
25 HTD 8M	25	62,29	200	200
26 HTD 8M	26	64,84	200	200
28 HTD 8M	28	69,93	200	200
30 HTD 8M	30	75,02	200	200
32 HTD 8M	32	80,12	200	200
34 HTD 8M	34	85,21	200	200
35 HTD 8M	35	87,76	200	200
36 HTD 8M	36	90,30	200	200
38 HTD 8M	38	95,40	200	200
40 HTD 8M	40	100,49	200	200
44 HTD 8M	44	110,68	200	200
48 HTD 8M	48	120,86	200	200

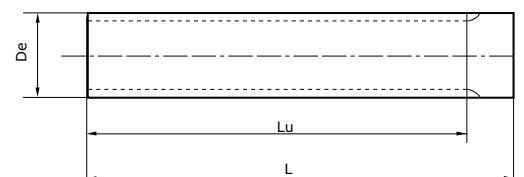

sedis 

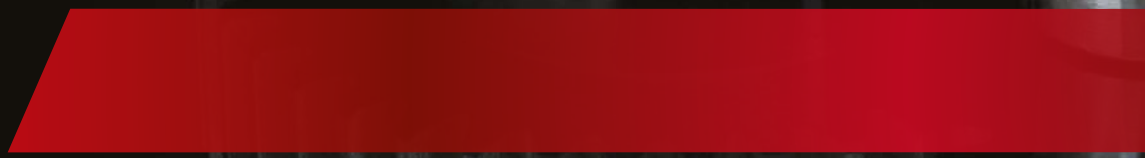

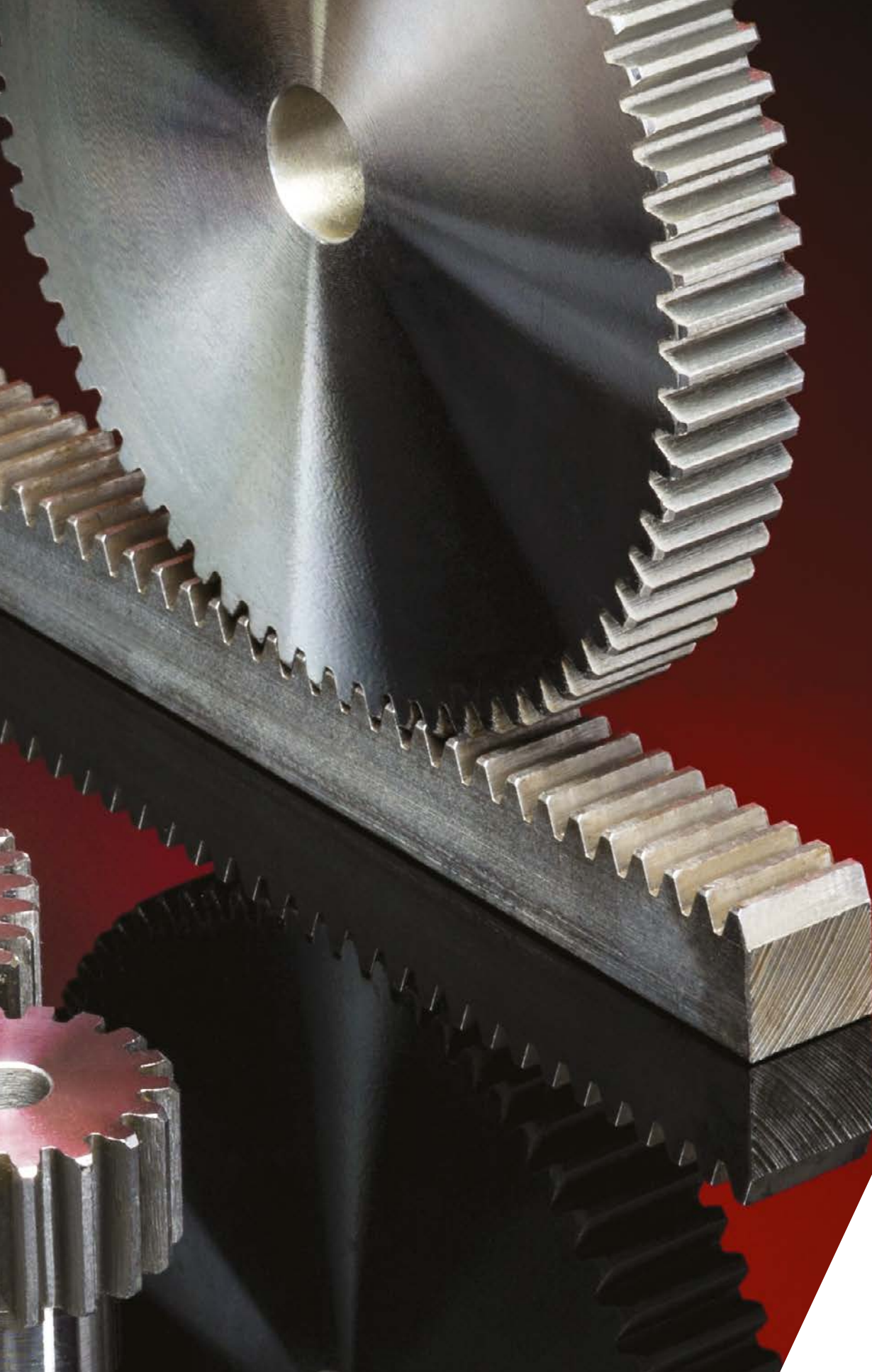

ZAHNRÄDER UND ZAHNSTANGEN

ZÄHRNÄDER MIT SEITLICHER NÄBE

MATERIAL: C43 UNI 7847
EINGRIFFSWINKEL: 20 °

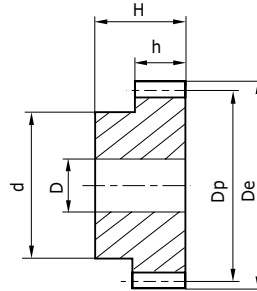

Modul 1 (h = 15 mm, H = 25 mm)

Art. Nr.	Z	De	Dp	d	D	Kg
EP 100 012	12	14	12	9	5	0,01
EP 100 013	13	15	13	10	5	0,02
EP 100 014	14	16	14	10	5	0,02
EP 100 015	15	17	15	12	6	0,02
EP 100 016	16	18	16	13	6	0,03
EP 100 017	17	19	17	14	8	0,03
EP 100 018	18	20	18	15	8	0,03
EP 100 019	19	21	19	15	8	0,04
EP 100 020	20	22	20	16	8	0,04
EP 100 021	21	23	21	16	8	0,05
EP 100 022	22	24	22	18	8	0,05
EP 100 023	23	25	23	18	8	0,06
EP 100 024	24	26	24	20	8	0,06
EP 100 025	25	27	25	20	8	0,07
EP 100 026	26	28	26	20	8	0,07
EP 100 027	27	29	27	20	8	0,08
EP 100 028	28	30	28	20	8	0,08
EP 100 029	29	31	29	20	8	0,09
EP 100 030	30	32	30	20	8	0,09
EP 100 031	31	33	31	25	10	0,11
EP 100 032	32	34	32	25	10	0,12
EP 100 033	33	35	33	25	10	0,12
EP 100 034	34	36	34	25	10	0,13
EP 100 035	35	37	35	25	10	0,14
EP 100 036	36	38	36	25	10	0,14
EP 100 037	37	39	37	25	10	0,15
EP 100 038	38	40	38	25	10	0,16
EP 100 039	39	41	39	25	10	0,16
EP 100 040	40	42	40	25	10	0,17
EP 100 041	41	43	41	30	10	0,19
EP 100 042	42	44	42	30	10	0,20
EP 100 043	43	45	43	30	10	0,21
EP 100 044	44	46	44	30	10	0,22
EP 100 045	45	47	45	30	10	0,23
EP 100 046	46	48	46	30	10	0,23
EP 100 047	47	49	47	30	10	0,24
EP 100 048	48	50	48	30	10	0,25
EP 100 049	49	51	49	30	10	0,26
EP 100 050	50	52	50	30	12	0,26
EP 100 051	51	53	51	40	12	0,32
EP 100 052	52	54	52	40	12	0,33
EP 100 053	53	55	53	40	12	0,33
EP 100 054	54	56	54	40	12	0,34
EP 100 055	55	57	55	40	12	0,36
EP 100 056	56	58	56	40	12	0,37
EP 100 057	57	59	57	40	12	0,38
EP 100 058	58	60	58	40	12	0,39
EP 100 059	59	61	59	40	12	0,40
EP 100 060	60	62	60	40	12	0,41
EP 100 061	61	63	61	50	12	0,47
EP 100 062	62	64	62	50	12	0,49
EP 100 063	63	65	63	50	12	0,50
EP 100 064	64	66	64	50	12	0,51
EP 100 065	65	67	65	50	12	0,52
EP 100 066	66	68	66	50	12	0,53
EP 100 067	67	69	67	50	12	0,55
EP 100 068	68	70	68	50	12	0,56
EP 100 069	69	71	69	50	12	0,57
EP 100 070	70	72	70	50	12	0,58

Modul 1,5 (h = 17 mm, H = 30 mm)

Art. Nr.	Z	De	Dp	d	D	Kg
EP 150 012	12	21	18	14	8	0,04
EP 150 013	13	22,5	19,5	14	8	0,05
EP 150 014	14	24	21	18	8	0,06
EP 150 015	15	25,5	22,5	18	8	0,07
EP 150 016	16	27	24	20	8	0,08
EP 150 017	17	28,5	25,5	20	8	0,09
EP 150 018	18	30	27	20	8	0,10
EP 150 019	19	31,5	28,5	20	8	0,10
EP 150 020	20	33	30	25	8	0,13
EP 150 021	21	34,5	31,5	25	10	0,13
EP 150 022	22	36	33	25	10	0,14
EP 150 023	23	37,5	34,5	25	10	0,16
EP 150 024	24	39	36	25	10	0,17
EP 150 025	25	40,5	37,5	25	10	0,18
EP 150 026	26	42	39	30	12	0,20
EP 150 027	27	43,5	40,5	30	12	0,22
EP 150 028	28	45	42	30	12	0,23
EP 150 029	29	46,5	43,5	30	12	0,24
EP 150 030	30	48	45	30	12	0,26
EP 150 031	31	49,5	46,5	35	12	0,30
EP 150 032	32	51	48	35	12	0,31
EP 150 033	33	52,5	49,5	35	12	0,33
EP 150 034	34	54	51	35	12	0,34
EP 150 035	35	55,5	52,5	35	12	0,36
EP 150 036	36	57	54	35	12	0,37
EP 150 037	37	58,5	55,5	40	12	0,42
EP 150 038	38	60	57	40	12	0,44
EP 150 039	39	60,5	58,5	40	12	0,46
EP 150 040	40	63	60	40	12	0,48
EP 150 041	41	64,5	61,5	50	14	0,50
EP 150 042	42	66	63	50	14	0,59
EP 150 043	43	67,5	64,5	50	14	0,61
EP 150 044	44	69	66	50	14	0,63
EP 150 045	45	70,5	67,5	50	14	0,65
EP 150 046	46	72	69	50	14	0,66
EP 150 047	47	73,5	70,5	50	14	0,70
EP 150 048	48	75	72	50	14	0,70
EP 150 049	49	76,5	73,5	50	14	0,73
EP 150 050	50	78	75	50	14	0,76
EP 150 051	51	79,5	76,5	60	15	0,86
EP 150 052	52	81	78	60	15	0,89
EP 150 053	53	82,5	79,5	60	15	0,91
EP 150 054	54	84	81	60	15	0,94
EP 150 055	55	85,5	82,5	60	15	0,96
EP 150 056	56	87	84	60	15	0,98
EP 150 057	57	88,5	85,5	60	15	1,00
EP 150 058	58	90	87	60	15	1,03
EP 150 059	59	91,5	88,5	60	15	1,06
EP 150 060	60	93	90	60	15	1,09
EP 150 061	61	94,5	91,5	70	20	1,22
EP 150 062	62	96	93	70	20	1,25
EP 150 063	63	97,5	94,5	70	20	1,28
EP 150 064	64	99	96	70	20	1,31
EP 150 065	65	100,5	97,5	70	20	1,34
EP 150 066	66	102	99	70	20	1,37
EP 150 067	67	103,5	100,5	70	20	1,40
EP 150 068	68	105	102	70	20	1,43
EP 150 069	69	106,5	103,5	70	20	1,46
EP 150 070	70	108	105	70	20	1,50



ZÄHRÄDER MIT SEITLICHER NÄBE

MATERIAL: C43 UNI 7847
EINGRIFFSWINKEL: 20 °

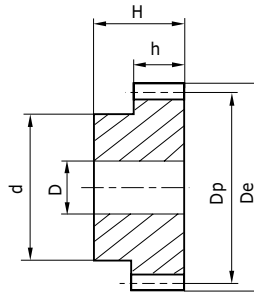

Modul 2 (h = 20 mm, H = 35 mm)						
Art. Nr.	Z	De	Dp	d	D	Kg
EP 200 012	12	28	24	18	10	0,08
EP 200 013	13	30	26	19	10	0,10
EP 200 014	14	32	28	20	10	0,12
EP 200 015	15	34	30	22	10	0,14
EP 200 016	16	36	32	24	10	0,16
EP 200 017	17	38	34	25	10	0,18
EP 200 018	18	40	36	25	10	0,19
EP 200 019	19	42	38	25	10	0,21
EP 200 020	20	44	40	30	10	0,26
EP 200 021	21	46	42	30	12	0,27
EP 200 022	22	48	44	30	12	0,29
EP 200 023	23	50	46	30	12	0,31
EP 200 024	24	52	48	35	12	0,36
EP 200 025	25	54	50	35	12	0,39
EP 200 026	26	56	52	40	12	0,45
EP 200 027	27	58	54	40	12	0,47
EP 200 028	28	60	56	40	12	0,50
EP 200 029	29	62	58	40	14	0,52
EP 200 030	30	64	60	40	14	0,55
EP 200 031	31	66	62	45	14	0,61
EP 200 032	32	68	64	45	14	0,65
EP 200 033	33	70	66	45	14	0,68
EP 200 034	34	72	68	45	14	0,71
EP 200 035	35	74	70	45	14	0,74
EP 200 036	36	76	72	45	14	0,78
EP 200 037	37	78	74	50	14	0,86
EP 200 038	38	80	76	50	14	0,90
EP 200 039	39	82	78	50	14	0,93
EP 200 040	40	84	80	50	14	0,97
EP 200 041	41	86	82	60	16	1,05
EP 200 042	42	88	84	60	16	1,09
EP 200 043	43	90	86	60	16	1,13
EP 200 044	44	92	88	60	16	1,23
EP 200 045	45	94	90	60	16	1,27
EP 200 046	46	96	92	60	16	1,31
EP 200 047	47	98	94	60	16	1,48
EP 200 048	48	100	96	70	16	1,53
EP 200 049	49	102	98	70	16	1,57
EP 200 050	50	104	100	70	16	1,62
EP 200 051	51	106	102	70	20	1,67
EP 200 052	52	108	104	70	20	1,72
EP 200 053	53	110	106	70	20	1,78
EP 200 054	54	112	108	70	20	1,83
EP 200 055	55	114	110	70	20	1,88
EP 200 056	56	116	112	70	20	1,94
EP 200 057	57	118	114	70	20	1,99
EP 200 058	58	120	116	70	20	2,05
EP 200 059	59	122	118	70	20	2,11
EP 200 060	60	124	120	70	20	2,16
EP 200 061	61	126	122	80	20	2,36
EP 200 062	62	128	124	80	20	2,42
EP 200 063	63	130	126	80	20	2,48
EP 200 064	64	132	128	80	20	2,55
EP 200 065	65	134	130	80	20	2,61
EP 200 066	66	136	132	80	20	2,67
EP 200 067	67	138	134	80	20	2,74
EP 200 068	68	140	136	80	20	2,81
EP 200 069	69	142	138	80	20	2,87
EP 200 070	70	144	140	80	20	2,94

Modul 2,5 (h = 25 mm, H = 40 mm)						
Art. Nr.	Z	De	Dp	d	D	Kg
EP 250 012	12	35	30	22	10	0,17
EP 250 013	13	37,5	32,5	25	10	0,21
EP 250 014	14	40,0	35,0	28	10	0,25
EP 250 015	15	42,5	37,5	30	10	0,30
EP 250 016	16	45	40	32	12	0,33
EP 250 017	17	47,5	42,5	35	12	0,38
EP 250 018	18	50	45	35	12	0,42
EP 250 019	19	52,5	47,5	35	12	0,45
EP 250 020	20	55	50	40	14	0,54
EP 250 021	21	57,5	52,5	40	14	0,56
EP 250 022	22	60	55	45	14	0,66
EP 250 023	23	62,5	57,5	45	14	0,70
EP 250 024	24	65	60	45	14	0,74
EP 250 025	25	67,5	62,5	50	14	0,85
EP 250 026	26	70	65	50	14	0,90
EP 250 027	27	72,5	67,5	50	14	0,95
EP 250 028	28	75	70	50	14	1,00
EP 250 029	29	77,5	72,5	50	14	1,06
EP 250 030	30	80	75	55	16	1,18
EP 250 031	31	82,5	77,5	55	16	1,22
EP 250 032	32	85	80	55	16	1,28
EP 250 033	33	87,5	82,5	55	16	1,34
EP 250 034	34	90	85	55	16	1,41
EP 250 035	35	92,5	87,5	60	16	1,54
EP 250 036	36	95	90	60	16	1,61
EP 250 037	37	97,5	92,5	60	16	1,68
EP 250 038	38	100	95	60	16	1,75
EP 250 039	39	102,5	97,5	60	16	1,83
EP 250 040	40	105	100	70	20	2,06
EP 250 041	41	107,5	102,5	70	20	2,14
EP 250 042	42	110	105	70	20	2,22
EP 250 043	43	112,5	107,5	70	20	2,30
EP 250 044	44	115	110	70	20	2,38
EP 250 045	45	117,5	112,5	70	20	2,47
EP 250 046	46	120	115	70	20	2,52
EP 250 047	47	122,5	117,5	80	20	2,80
EP 250 048	48	125	120	80	20	2,88
EP 250 049	49	127,5	122,5	80	20	2,98
EP 250 050	50	130	125	80	20	3,07
EP 250 051	51	132,5	127,5	90	20	3,17
EP 250 052	52	135	130	90	20	3,48
EP 250 053	53	137,5	132,5	90	20	3,58
EP 250 054	54	140	135	90	20	3,68
EP 250 055	55	142,5	137,5	90	20	3,78
EP 250 056	56	145	140	100	20	4,13
EP 250 057	57	147,5	142,5	100	20	4,23
EP 250 058	58	150	145	100	20	4,34
EP 250 059	59	152,5	147,5	100	20	4,46
EP 250 060	60	155	150	100	20	4,57



ZAHNRÄDER MIT SEITLICHER NABE

MATERIAL: C43 UNI 7847
EINGRIFFSWINKEL: 20 °

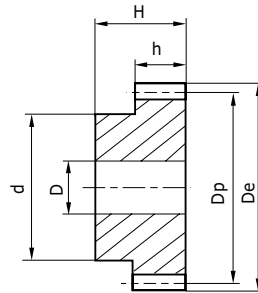

Modul 3 (h = 30 mm, H = 50 mm)						
Art. Nr.	Z	De	Dp	d	D	Kg
EP 300 012	12	42	36	25	12	0,28
EP 300 013	13	45	39	25	12	0,34
EP 300 014	14	48	42	30	12	0,41
EP 300 015	15	51	45	35	12	0,47
EP 300 016	16	54	48	38	15	0,54
EP 300 017	17	57	51	42	15	0,63
EP 300 018	18	60	54	45	15	0,72
EP 300 019	19	63	57	45	15	0,78
EP 300 020	20	66	60	45	15	0,84
EP 300 021	21	69	63	45	15	0,89
EP 300 022	22	72	66	50	15	1,02
EP 300 023	23	75	69	50	15	1,10
EP 300 024	24	78	72	50	15	1,18
EP 300 025	25	81	75	60	16	1,39
EP 300 026	26	84	78	60	16	1,48
EP 300 027	27	87	81	60	16	1,56
EP 300 028	28	90	84	60	16	1,66
EP 300 029	29	93	87	60	16	1,75
EP 300 030	30	96	90	60	16	1,85
EP 300 031	31	99	93	70	20	1,95
EP 300 032	32	102	96	70	20	2,21
EP 300 033	33	105	99	70	20	2,32
EP 300 034	34	108	102	70	20	2,43
EP 300 035	35	111	105	70	20	2,55
EP 300 036	36	114	108	70	20	2,62
EP 300 037	37	117	111	80	20	2,74
EP 300 038	38	120	114	80	20	3,05
EP 300 039	39	123	117	80	20	3,18
EP 300 040	40	126	120	80	20	3,31
EP 300 041	41	129	123	90	20	3,44
EP 300 042	42	132	126	90	20	3,58
EP 300 043	43	135	129	90	20	3,72
EP 300 044	44	138	132	90	20	4,07
EP 300 045	45	141	135	90	20	4,22
EP 300 046	46	144	138	90	20	4,37
EP 300 047	47	147	141	90	20	4,76
EP 300 048	48	150	144	100	20	4,92

Modul 4 (h = 40 mm, H = 60 mm)						
Art. Nr.	Z	De	Dp	d	D	Kg
EP 400 012	12	56	48	35	14	0,63
EP 400 013	13	60	52	40	14	0,78
EP 400 014	14	64	56	45	14	0,93
EP 400 015	15	68	60	45	14	1,05
EP 400 016	16	72	64	50	15	1,20
EP 400 017	17	76	68	50	15	1,33
EP 400 018	18	80	72	50	15	1,47
EP 400 019	19	84	76	60	15	1,75
EP 400 020	20	88	80	60	15	1,90
EP 400 021	21	92	84	70	20	2,22
EP 400 022	22	96	88	70	20	2,39
EP 400 023	23	100	92	75	20	2,60
EP 400 024	24	104	96	75	20	2,79
EP 400 025	25	108	100	75	20	2,98
EP 400 026	26	112	104	75	20	3,18
EP 400 027	27	116	108	75	20	3,39
EP 400 028	28	120	112	75	20	3,60
EP 400 029	29	124	116	75	20	3,83
EP 400 030	30	128	120	75	20	4,06
EP 400 031	31	132	124	80	20	4,39
EP 400 032	32	136	128	80	20	4,64
EP 400 033	33	140	132	80	20	4,90
EP 400 034	34	144	136	80	20	5,16
EP 400 035	35	148	140	80	20	5,43
EP 400 036	36	152	144	80	20	5,63



ZAHNRÄDER MIT SEITLICHER NABE

MATERIAL: C43 UNI 7847
EINGRIFFSWINKEL: 20 °

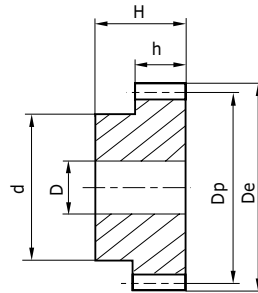

Modul 5
(h = 50 mm, H = 75 mm)

Art. Nr.	Z	De	Dp	d	D	Kg
EP 500 012	12	70	60	45	16	1,21
EP 500 013	13	75	65	50	16	1,47
EP 500 014	14	80	70	55	20	1,76
EP 500 015	15	85	75	60	20	2,07
EP 500 016	16	90	80	65	20	2,40
EP 500 017	17	95	85	70	20	2,75
EP 500 018	18	100	90	70	20	3,02
EP 500 019	19	105	95	70	20	3,30
EP 500 020	20	110	100	80	20	3,83
EP 500 021	21	115	105	80	20	4,15
EP 500 022	22	120	110	80	25	4,48
EP 500 023	23	125	115	90	25	5,08
EP 500 024	24	130	120	90	25	5,44
EP 500 025	25	135	125	90	25	5,82
EP 500 026	26	140	130	100	25	6,50
EP 500 027	27	145	135	100	25	6,91
EP 500 028	28	150	140	100	25	7,22
EP 500 029	29	155	145	100	25	7,98
EP 500 030	30	160	150	100	25	8,44
EP 500 032	32	170	160	110	25	7,62

Modul 6
(h = 60 mm, H = 80 mm)

Art. Nr.	Z	De	Dp	d	D	Kg
EP 600 012	12	84	72	54	20	1,82
EP 600 013	13	90	78	60	20	2,20
EP 600 015	15	102	90	70	20	3,01
EP 600 016	16	108	96	75	20	3,46
EP 600 018	18	120	108	80	20	4,33
EP 600 020	20	132	120	90	20	5,43
EP 600 024	24	156	144	110	25	7,88
EP 600 025	25	162	150	110	25	8,42

Modul 8
(h = 80 mm, H = 110 mm)

Art. Nr.	Z	De	Dp	d	D	Kg
EP 800 015	15	136	120	90	25	7,96
EP 800 018	18	160	144	100	25	11,34
EP 800 020	20	176	160	120	30	14,38
EP 800 024	24	208	192	150	30	21,25
EP 800 025	25	210	200	150	30	22,85
EP 800 030	30	256	241	190	30	33,50

Technische Daten:

Dp = Teilkreisdurchmesser
De = Außendurchmesser
Z = Anzahl der Zähne
m = Modul

$Dp = Z \times m$
 $De = Dp + (2 \times m)$



VORGEBOHRTE ZAHNRÄDER MIT SEITLICHER NABE

MATERIAL: C43 UNI 7847
EINGRIFFSWINKEL: 20 °



Zahnräder mit seitlicher Nabe, induktionsgehärtete Zähne 50 HRC +/-3.

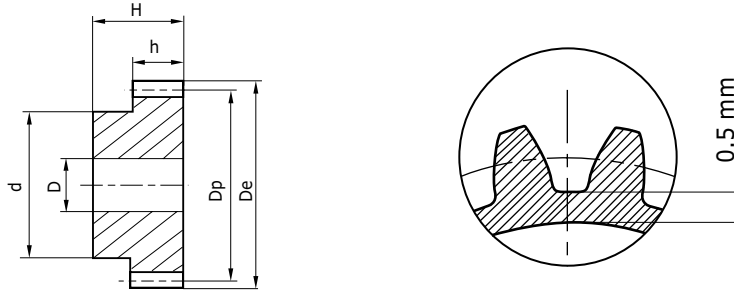

Modul 2 (h = 20 mm, H = 35 mm)

Art. Nr.	Z	De	Dp	d	D	Kg
EP 200 012 DTTT	12	28	24	18	10	0,08
EP 200 015 DTTT	15	34	30	22	10	0,14
EP 200 018 DTTT	18	40	36	25	10	0,19
EP 200 020 DTTT	20	44	40	30	10	0,26
EP 200 024 DTTT	24	52	48	35	12	0,36
EP 200 025 DTTT	25	54	50	35	12	0,39
EP 200 030 DTTT	30	64	60	40	14	0,55
EP 200 036 DTTT	36	76	72	45	14	0,78
EP 200 040 DTTT	40	84	80	50	14	0,97
EP 200 050 DTTT	50	104	100	70	16	1,62
EP 200 060 DTTT	60	124	120	70	20	2,16

Modul 2,5 (h = 25 mm, H = 40 mm)

Art. Nr.	Z	De	Dp	d	D	Kg
EP 250 012 DTTT	12	35	30	22	10	0,17
EP 250 015 DTTT	15	42,5	37,5	30	10	0,30
EP 250 018 DTTT	18	50	45	35	12	0,42
EP 250 020 DTTT	20	55	50	40	14	0,54
EP 250 024 DTTT	24	65	60	45	14	0,74
EP 250 025 DTTT	25	67,5	62,5	50	14	0,85
EP 250 030 DTTT	30	80	75	55	16	1,18
EP 250 036 DTTT	36	95	90	60	16	1,61
EP 250 040 DTTT	40	105	100	70	20	2,06
EP 250 050 DTTT	50	130	125	80	20	3,07
EP 250 060 DTTT	60	155	150	100	20	4,57

Modul 3

(h = 30 mm, H = 50 mm)

Art. Nr.	Z	De	Dp	d	D	Kg
EP 300 012 DTTT	12	42	36	25	12	0,28
EP 300 015 DTTT	15	51	45	35	12	0,47
EP 300 018 DTTT	18	60	54	45	15	0,72
EP 300 020 DTTT	20	66	60	45	15	0,84
EP 300 024 DTTT	24	78	72	50	15	1,18
EP 300 025 DTTT	25	81	75	60	16	1,39
EP 300 030 DTTT	30	96	90	60	16	1,85
EP 300 036 DTTT	36	114	108	70	20	2,62
EP 300 040 DTTT	40	126	120	80	20	3,31



VORGEBOHRTE ZÄHRÄDER MIT SEITLICHER NABE

MATERIAL: C43 UNI 7847
EINGRIFFSWINKEL: 20 °



ZÄHRÄDER mit seitlicher Nabe, induktionsgehärtete ZÄHNE 50 HRC +/-3.

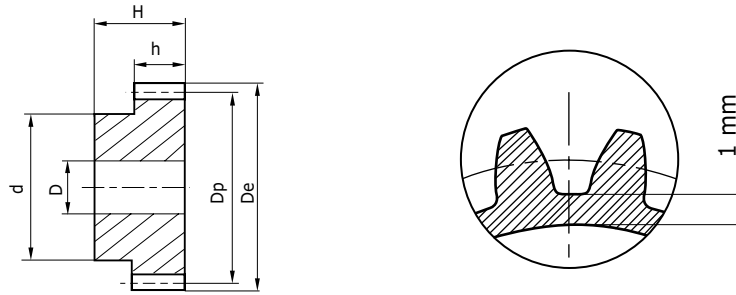

Modul 4 (h = 40 mm, H = 60 mm)						
Art. Nr.	Z	De	Dp	d	D	Kg
EP 400 012 DTTT	12	56	48	35	14	0,63
EP 400 015 DTTT	15	68	60	45	14	1,05
EP 400 018 DTTT	18	80	72	50	15	1,47
EP 400 020 DTTT	20	88	80	60	15	1,90
EP 400 024 DTTT	24	104	96	75	20	2,79
EP 400 025 DTTT	25	108	100	75	20	2,98
EP 400 030 DTTT	30	128	120	75	20	4,06
EP 400 036 DTTT	36	152	144	80	20	5,63

Modul 5 (h = 50 mm, H = 75 mm)						
Art. Nr.	Z	De	Dp	d	D	Kg
EP 500 012 DTTT	12	70	60	45	16	1,21
EP 500 015 DTTT	15	85	75	60	20	2,07
EP 500 018 DTTT	18	100	90	70	20	3,02
EP 500 020 DTTT	20	110	100	80	20	3,83
EP 500 024 DTTT	24	130	120	90	25	5,44
EP 500 025 DTTT	25	135	125	90	25	5,82
EP 500 030 DTTT	30	160	150	100	25	8,44

Modul 6 (h = 60 mm, H = 80 mm)						
Art. Nr.	Z	De	Dp	d	D	Kg
EP 600 012 DTTT	12	84	72	54	20	1,82
EP 600 015 DTTT	15	102	90	70	20	3,01
EP 600 018 DTTT	18	120	108	80	20	4,33
EP 600 020 DTTT	20	132	120	90	20	5,43
EP 600 024 DTTT	24	156	144	110	25	7,88
EP 600 025 DTTT	25	162	150	110	25	8,42

ZAHNRÄDER OHNE NABE

MATERIAL: C43 UNI 7847
EINGRIFFSWINKEL: 20 °

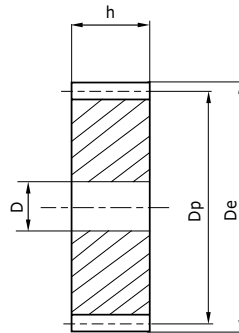

Modul 1 (h = 15 mm)					
Art. Nr.	Z	De	Dp	D	Kg
ED 100 072	72	74	72	12	0,46
ED 100 075	75	77	75	12	0,51
ED 100 076	76	78	76	12	0,52
ED 100 080	80	82	80	12	0,58
ED 100 085	85	87	85	12	0,65
ED 100 090	90	92	90	12	0,73
ED 100 095	95	97	95	12	0,82
ED 100 100	100	102	100	12	0,91
ED 100 110	110	112	110	12	1,10
ED 100 114	114	116	114	12	1,19
ED 100 120	120	122	120	12	1,32
ED 100 127	127	129	127	12	1,47

Modul 1,5 (h = 17 mm)					
Art. Nr.	Z	De	Dp	D	Kg
ED 150 072	72	111	108	20	1,19
ED 150 075	75	115,5	112,5	20	1,30
ED 150 076	76	117	114	20	1,33
ED 150 080	80	123	120	20	1,48
ED 150 085	85	130,5	127,5	20	1,67
ED 150 090	90	138	135	20	1,88
ED 150 095	95	145,5	142,5	20	2,09
ED 150 100	100	153	150	20	2,32
ED 150 110	110	168	165	20	2,82
ED 150 114	114	174	171	20	3,03
ED 150 120	120	183	180	20	3,36
ED 150 127	127	193,5	190,5	20	3,77

Modul 2,5 (h = 25 mm)					
Art. Nr.	Z	De	Dp	D	Kg
ED 250 065	65	167,5	162,5	20	3,99
ED 250 070	70	180	175	20	4,64
ED 250 072	72	185	180	20	4,91
ED 250 075	75	192,5	187,5	20	5,33
ED 250 076	76	195	190	20	5,48
ED 250 080	80	205	200	25	6,04
ED 250 085	85	217,5	212,5	25	6,84
ED 250 090	90	230	225	25	7,68
ED 250 095	95	242,5	237,5	25	8,57
ED 250 100	100	255	250	25	9,51
ED 250 110	110	280	275	25	11,53
ED 250 114	114	290	285	25	12,39
ED 250 120	120	305	300	25	13,74
ED 250 127	127	322,5	317,5	25	15,40

Modul 2 (h = 20 mm)					
Art. Nr.	Z	De	Dp	D	Kg
ED 200 072	72	148	144	20	2,50
ED 200 075	75	154	150	20	2,71
ED 200 076	76	156	152	20	2,79
ED 200 080	80	164	160	20	3,09
ED 200 085	85	174	170	20	3,50
ED 200 090	90	184	180	20	3,93
ED 200 095	95	194	190	20	4,39
ED 200 100	100	204	200	20	4,87
ED 200 110	110	224	220	20	5,90
ED 200 114	114	232	228	20	6,34
ED 200 120	120	244	240	20	7,03
ED 200 127	127	258	254	20	7,89



ZÄHRÄDER OHNE NÄBE

MATERIAL: C43 UNI 7847
EINGRIFFSWINKEL: 20 °

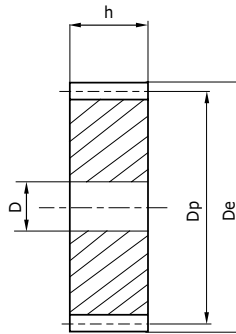

Modul 3 (h = 30 mm)					
Art. Nr.	Z	De	Dp	D	Kg
ED 300 050	50	156	150	25	4,06
ED 300 052	52	162	156	25	4,40
ED 300 055	55	171	165	25	4,93
ED 300 057	57	177	171	25	5,30
ED 300 060	60	186	180	25	5,89
ED 300 065	65	201	195	25	6,92
ED 300 070	70	216	210	25	8,00
ED 300 072	72	222	216	25	8,47
ED 300 075	75	231	225	25	9,21
ED 300 076	76	234	228	25	9,46
ED 300 080	80	246	240	25	10,49
ED 300 085	85	261	255	25	11,86
ED 300 090	90	276	270	25	13,32
ED 300 095	95	291	285	25	14,86
ED 300 100	100	306	300	25	16,48
ED 300 110	110	336	330	25	19,97
ED 300 114	114	348	342	30	21,40
ED 300 120	120	366	360	30	23,74
ED 300 127	127	387	381	30	26,61

Modul 4 (h = 40 mm)					
Art. Nr.	Z	De	Dp	D	Kg
ED 400 038	38	160	152	25	5,20
ED 400 040	40	168	160	25	6,11
ED 400 045	45	188	180	25	7,78
ED 400 048	48	200	192	25	8,87
ED 400 050	50	208	200	25	9,65
ED 400 052	52	216	208	25	10,45
ED 400 055	55	228	220	25	11,71
ED 400 057	57	236	228	25	12,59
ED 400 060	60	248	240	25	13,97
ED 400 065	65	268	260	25	16,43
ED 400 070	70	288	280	25	19,09
ED 400 075	75	308	300	25	21,94
ED 400 076	76	312	304	25	22,47
ED 400 080	80	328	320	25	24,93
ED 400 085	85	348	340	25	28,18
ED 400 090	90	368	360	25	31,62
ED 400 095	95	388	380	25	35,26
ED 400 100	100	408	400	25	39,11
ED 400 110	110	448	440	25	47,38
ED 400 114	114	464	456	25	50,91

Modul 5 (h = 50 mm)					
Art. Nr.	Z	De	Dp	D	Kg
ED 500 032	32	170	160	25	7,62
ED 500 035	35	185	175	25	9,16
ED 500 038	38	200	190	30	10,84
ED 500 040	40	210	200	30	12,04
ED 500 045	45	235	225	30	15,30
ED 500 048	48	250	240	30	17,44
ED 500 050	50	260	250	30	18,86
ED 500 052	52	270	260	30	20,43
ED 500 055	55	285	275	30	22,89
ED 500 057	57	295	285	30	24,62
ED 500 060	60	310	300	30	27,31
ED 500 065	65	335	325	30	32,12
ED 500 070	70	360	350	30	37,31
ED 500 075	75	385	375	30	42,88
ED 500 076	76	390	380	30	44,04
ED 500 080	80	410	400	30	48,84
ED 500 085	85	435	425	30	55,19
ED 500 090	90	460	450	30	61,92
ED 500 095	95	485	475	30	69,03
ED 500 100	100	510	500	30	76,53
ED 500 110	110	560	550	30	92,69
ED 500 114	114	580	570	30	99,59

Modul 6 (h = 60 mm)					
Art. Nr.	Z	De	Dp	D	Kg
ED 600 028	28	180	168	25	8,41
ED 600 030	30	192	180	25	9,69
ED 600 032	32	204	192	25	11,05
ED 600 035	35	222	210	25	13,27
ED 600 038	38	240	220	25	15,69
ED 600 040	40	252	240	25	17,42

ZAHNSTANGEN AUS VIERKANTSTAHL

MATERIAL: C43 UNI 7847
EINGRIFFSWINKEL: 20 °

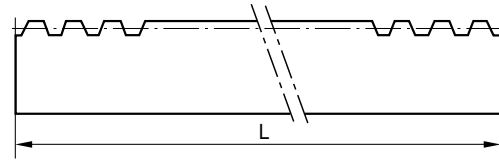
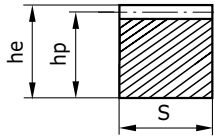

Modul	he x S	hp	L	Kg	Art. Nr.
1	15 x 15	14,0	500	0,824	RC 10 0500
	15 x 15	14,0	1,000	1,648	RC 10 1000
	15 x 15	14,0	2,000	3,050	RC 10 2000
	15 x 15	14,0	3,000	4,900	RC 10 3000
1,5	17 x 17	15,5	500	1,035	RC 15 0500
	17 x 17	15,5	1,000	2,070	RC 15 1000
	17 x 17	15,5	2,000	3,830	RC 15 2000
	17 x 17	15,5	3,000	6,100	RC 15 3000
2	20 x 20	18,0	500	1,410	RC 20 0500
	20 x 20	18,0	1,000	2,820	RC 20 1000
	20 x 20	18,0	2,000	5,115	RC 20 2000
2,5	20 x 20	18,0	3,000	8,400	RC 20 3000
	25 x 25	22,5	500	1,985	RC 25 0500
	25 x 25	22,5	1,000	3,970	RC 25 1000
	25 x 25	22,5	2,000	7,350	RC 25 2000
3	25 x 25	22,5	2,000	11,900	RC 25 3000
	30 x 30	27,0	500	3,100	RC 30 0500
	30 x 30	27,0	1,000	6,200	RC 30 1000
	30 x 30	27,0	2,000	11,470	RC 30 2000
4	30 x 30	27,0	3,000	18,600	RC 30 3000
	25 x 25	21,0	500	1,825	RCS 40 0500
	25 x 25	21,0	1,000	3,650	RCS 40 1000
	25 x 25	21,0	2,000	7,300	RCS 40 2000
	30 x 30	26,0	500	3,050	RCT 40 0500
	30 x 30	26,0	1,000	6,100	RCT 40 1000
	30 x 30	26,0	2,000	11,700	RCT 40 2000
	40 x 40	36,0	500	5,500	RC 40 0500
5	40 x 40	36,0	1,000	11,000	RC 40 1000
	40 x 40	36,0	2,000	20,350	RC 40 2000
	40 x 40	36,0	3,000	31,300	RC 40 3000
	50 x 50	45,0	500	7,950	RC 50 0500
6	50 x 50	45,0	1,000	15,900	RC 50 1000
	50 x 50	45,0	2,000	29,415	RC 50 2000
	50 x 50	45,0	3,000	45,300	RC 50 3000
	60 x 60	54,0	500	12,650	RC 60 0500
8	60 x 60	54,0	1,000	24,300	RC 60 1000
	60 x 60	54,0	2,000	50,200	RC 60 2000
	60 x 60	54,0	3,000	72,900	RC 60 3000
	80 x 80	72,0	500	16,870	RC 80 0500
8	80 x 80	72,0	1,000	32,400	RC 80 1000
	80 x 80	72,0	2,000	97,200	RC 80 2000

Technische Daten:

- Toleranz an der Teilung +/- 20 Mikron
- Toleranz an der Summe der Teilungen +/- 30 Mikron auf 500 mm
- Qualitätsstufe der Zahnung: von 8 bis 9 mm gemäß Norm DIN 3662/63/67
- Gerade Zahnung

Alle unsere Zahnstangen sind durch aneinanderreihende Montage verlängerbar.

Bestimmung der Länge einer Zahnstange L:

$$L = n \times \text{Modul} \times \text{Anzahl der Zähne}$$



TECHNISCHE DATEN - VERZÄHNUNG IM MASSSTAB 1/1 - 100%

ZÄHRÄDER

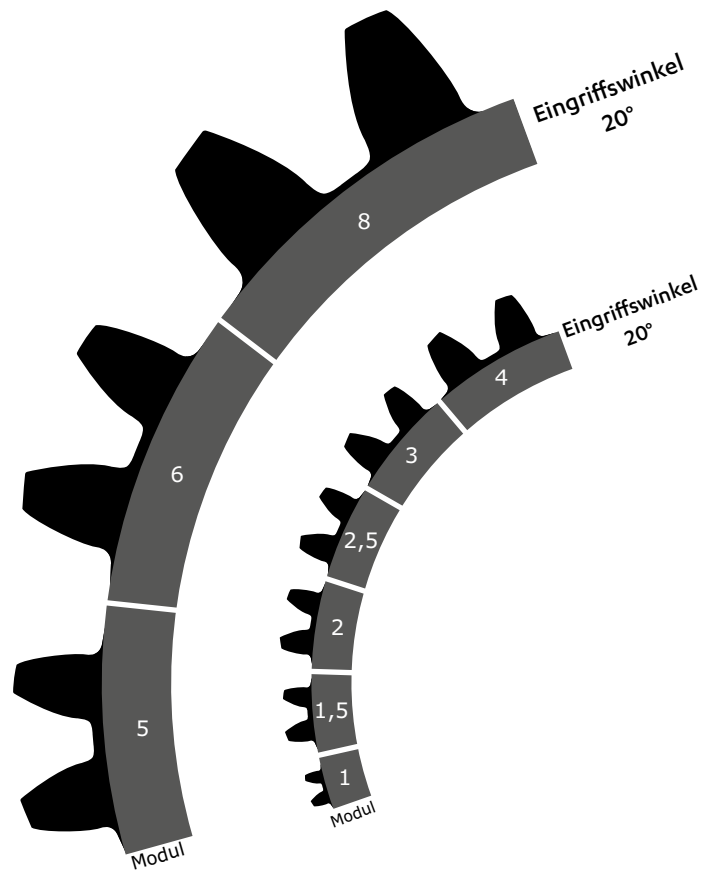

ZÄHNSTANGEN

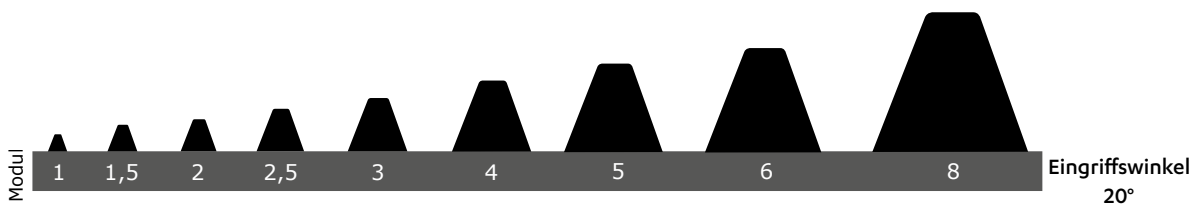

sedis 





KEGELRÄDER



KEGELRÄDER MIT GERADEN ZÄHNEN - TYP A

MATERIAL:

Stahl: C43 UNI 7847

EINGRIFFSWINKEL: 20 °

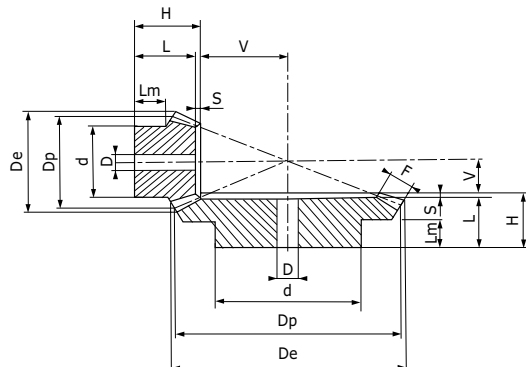

VERHÄLTNIS 1/1													
Modul	Art. Nr.	Z	De	Dp	H	F	d	D	V	L	Lm	S	Kg
1,5	CCA 15 1616	16 / 16	26,1	24,0	18,9	6	20,3	8	7,10	19,9	12	2	0,03
	CCA 15 2020	20 / 20	32,1	30,0	20,0	10	22	10	7,40	18	8,5	2	0,05
	CCA 15 2525	25 / 25	39,6	37,5	23,0	10	28	10	11,09	21	12	2	0,10
	CCA 15 2222	22 / 22	35,1	33,0	20,0	10	25	10	10,20	18	9,7	2	0,07
2	CCA 15 3030	30 / 30	47,1	45,0	25,0	12	30	12	13,35	22,5	12	2,5	0,15
	CCA 20 1616	16 / 16	34,8	32,0	23,5	8	25,3	10	9,50	20,5	14	3	0,06
	CCA 20 2020	20 / 20	42,8	40,0	25,0	12	32	10	10,78	22	12	3	0,14
	CCA 20 2222	22 / 22	46,8	44,0	25,0	12	36	10	12,70	22	11,7	3	0,20
2,5	CCA 20 2525	25 / 25	52,8	50,0	28,0	14	40	12	14,28	25	12,3	3	0,25
	CCA 20 3030	30 / 30	62,8	60,0	30,0	16	50	12	17,78	27	12,8	3	0,41
	CCA 25 1616	16 / 16	43,5	40,0	28,1	10	30,3	12	11,90	25,1	15	3,5	0,13
	CCA 25 2020	20 / 20	53,5	50,0	30,5	12	40	12	15,43	27	16	3,5	0,27
3	CCA 25 2222	22 / 22	58,5	55,0	30,5	12	45	12	17,80	27	15,9	3,5	0,37
	CCA 25 2525	25 / 25	66,0	62,5	33,5	15	50	15	19,48	30	16	3,5	0,47
	CCA 25 3030	30 / 30	78,5	75,0	35,5	18	55	15	23,63	32	16	3,5	0,69
	CCA 30 1616	16 / 16	52,2	48,0	31,7	12	40,3	15	14,30	28	18	4	0,24
3,5	CCA 30 2020	20 / 20	64,2	60,0	35,0	18	45	15	16,00	31	13,6	4	0,41
	CCA 30 2222	22 / 22	70,2	66,0	35,0	18	50	15	19,00	31	13	4	0,53
	CCA 30 2525	25 / 25	79,2	75,0	38,0	20	55	15	22,00	34	16	4	0,72
	CCA 30 3030	30 / 30	94,2	90,0	40,0	22	60	20	28,00	36	17	4	0,99
4	CCA 35 1616	16 / 16	60,9	56,0	36,4	14	45,3	15	16,60	32	20	4,5	0,38
	CCA 35 2020	20 / 20	74,9	70,0	40,5	22	55	15	18,13	36	17	4,5	0,68
	CCA 35 2222	22 / 22	81,9	77,0	40,5	22	60	15	21,5	36	18	4,5	0,93
	CCA 35 2525	25 / 25	92,4	87,5	43,5	26	65	20	23,97	39	18	4,5	1,10
4,5	CCA 35 3030	30 / 30	109,9	105,0	48,0	30	70	20	30,02	43,5	19	4,5	1,61
	CCA 40 1616	16 / 16	69,6	64,0	44,3	15	50,3	15	19,70	39,8	25	5	0,52
	CCA 40 2020	20 / 20	85,6	80,0	43,0	25	60	18	20,74	38	18	5	0,90
	CCA 40 2222	22 / 22	93,6	88,0	43	25	65	18	24,10	38	18	5	1,15
5	CCA 40 2525	25 / 25	105,6	100,0	45,0	28	70	20	28,50	40	18	5	1,45
	CCA 40 3030	30 / 30	125,6	120,0	48,0	32	80	25	35,67	43	16	5	2,66
	CCA 45 1616	16 / 16	78,3	72,0	46,3	18	55,3	18	21,70	41,3	25	6	0,73
	CCA 45 2020	20 / 20	96,3	90,0	48,0	28	65	20	23,41	42	18	6	1,25
5	CCA 45 2222	22 / 22	105,3	93,0	48	28	70	20	27,80	42	18	6	1,75
	CCA 45 2525	25 / 25	118,8	112,5	50,0	32	75	20	31,76	44	18	6	2,04
	CCA 45 3030	30 / 30	141,3	135,0	53,0	35	90	25	40,82	47	17	6	3,24
	CCA 50 1616	16 / 16	87,0	80,0	48,9	18	60,3	20	25,10	42,9	25	6,5	0,94
5	CCA 50 2020	20 / 20	107,1	100,0	50,5	30	70	20	26,86	44	18,5	6,5	1,61
	CCA 50 2222	22 / 22	117,1	110,0	50,5	30	80	20	31,70	44	18,5	6,5	2,35
	CCA 50 2525	25 / 25	132,1	125,0	53,5	34	90	20	36,36	47	18	6,5	2,94
	CCA 50 3030	30 / 30	157,1	150,0	56,5	38	110	30	45,97	50	18	6,5	4,46



KEGELRÄDER MIT GERADEN ZÄHNEN - TYP A

MATERIAL:

Stahl: C43 UNI 7847

EINGRIFFSWINKEL: 20 °

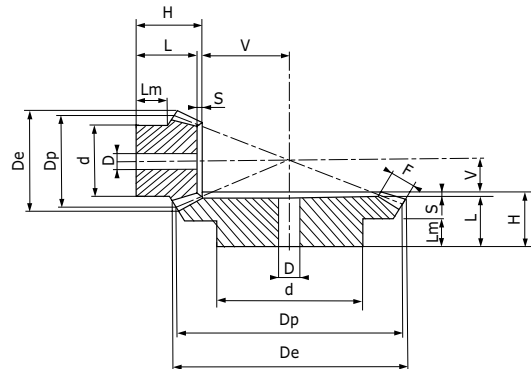

VERHÄLTNIS 1/2													
Modul	Art. Nr.	Z	De	Dp	H	F	d	D	V	L	Lm	S	Kg
1,5	CCA 15 1632	16	26,7	24,0	19,5	8	21	10	16,33	18	11,3	1,5	0,04
		32	49,3	48,0	20,0	8	32	12	7,45	17	10,0	3	0,14
2	CCA 20 1632	16	35,6	32,0	23,0	10	26	10	22,41	21	12,2	2	0,09
		32	65,8	64,0	25,0	10	40	12	10,21	21	10,0	4	0,14
2,5	CCA 25 1632	16	44,4	40,0	27,5	12	34	12	28,38	25	14,4	2,5	0,16
		32	82,2	80,0	25,0	12	50	15	14,10	20	10,0	5	0,59
3	CCA 30 1632	16	53,4	48,0	28,0	15	40	15	33,64	25	11,6	3	0,23
		32	98,7	96,0	30,0	15	60	15	15,31	24	10,0	6	1,05
3,5	CCA 35 1632	16	62,3	56,0	33,5	18	48	15	38,83	30	14,4	3,5	0,40
		32	115,1	112,0	31,0	18	70	20	17,77	24	10,0	7	1,57
4	CCA 40 1632	16	71,1	64,0	36,0	20	50	20	44,81	32	13,4	4	0,49
		32	131,6	128,0	32,0	20	80	20	20,42	24	10,0	8	2,29
4,5	CCA 45 1632	16	80,1	72,0	39,5	22	60	20	51,00	35	15,4	4,5	0,75
		32	148,0	144,0	36,0	22	90	25	23,21	27	10,0	9	2,99
5	CCA 50 1632	16	88,9	80,0	50,0	25	60	20	56,06	45	21,1	5	1,07
		32	164,5	160,0	38,0	25	100	25	25,52	28	10,0	10	3,95

VERHÄLTNIS 1/3													
Modul	Art. Nr.	Z	De	Dp	H	F	d	D	V	L	Lm	S	Kg
1,5	CCA 15 1648	16	26,9	24,0	24,0	12	20	10	22,44	23	11,7	1,0	0,04
		48	72,9	72,0	20,0	12	50	15	7,27	17	10,0	3,0	0,31
2	CCA 20 1648	16	35,8	32,0	28,5	15	26	12	33,26	27	12,4	1,5	0,08
		48	97,3	96,0	23,0	15	60	15	9,90	19	10,0	4,0	0,67
2,5	CCA 25 1648	16	44,7	40,0	32,0	18	32	12	42,41	30	13,0	2,0	0,15
		48	121,6	120,0	26,0	18	70	20	13,23	21	10,0	5,0	1,22
3	CCA 30 1648	16	53,7	48,0	32,0	18	40	15	54,25	30	12,1	2,0	0,27
		48	145,9	144,0	29,0	18	80	20	16,20	23	10,0	6,0	2,01
3,5	CCA 35 1648	16	62,6	56,0	38,0	22	48	15	62,29	35,5	15,0	2,5	0,45
		48	170,2	168,0	31,0	22	90	20	18,48	24	10,0	7,0	3,08
4	CCA 40 1648	16	71,6	64,0	41,5	25	55	20	71,23	38,8	15,2	3,0	0,67
		48	194,5	192,0	33,0	25	100	22	21,20	25	10,0	8,0	4,40
4,5	CCA 45 1648	16	80,6	72,0	53,0	28	60	20	80,27	50	23,4	3,0	1,05
		48	218,6	216,0	49,0	28	100	25	23,93	40	18,0	9,0	7,23
5	CCA 50 1648	16	89,5	80,0	60,0	35	60	20	85,61	57	22,5	3,0	1,38
		48	243,1	240,0	50,0	35	150	28	25,45	40	20,0	10,0	8,72

VERHÄLTNIS 1/4													
Modul	Art. Nr.	Z	De	Dp	H	F	d	D	V	L	Lm	S	Kg
1,5	CCA 15 1664	16	26,9	24,0	25,0	12	18	10	36,02	24	12,2	1	0,04
		64	96,7	96,0	22,0	12	70	15	8,53	19	10,0	3	0,75
2	CCA 20 1664	16	35,9	32,0	24,0	15	25	12	49,07	23	8,2	1	0,08
		64	129,0	128,0	24,0	15	80	20	11,79	20	10,0	4	1,35
2,5	CCA 25 1664	16	44,9	40,0	30,5	18	30	15	61,99	26	8,2	1,5	0,18
		64	161,2	160,0	29,0	18	90	20	13,77	24	10,0	5	2,70
3	CCA 30 1664	16	53,8	48,0	34,0	22	40	15	74,05	32	11,0	2	0,29
		64	193,5	192,0	30,0	22	100	20	16,41	24	10,0	6	4,12
3,5	CCA 35 1664	16	62,8	56,0	45,0	25	48	15	87,13	43	19,1	2	0,48
		64	225,7	224,0	50,0	25	100	25	19,32	43	22,0	7	7,53
4	CCA 40 1664	16	71,7	64,0	50,0	30	50	20	98,21	48	18,5	2	0,75
		64	257,9	256,0	50,0	30	120	28	21,72	42	20,0	8	10,66
4,5	CCA 45 1664	16	80,7	72,0	53,0	32	55	20	112,08	50,5	19,0	2,5	1,12
		64	290,1	288,0	53,0	32	130	30	24,83	44	23,0	9	13,80
5	CCA 50 1664	16	89,7	80,0	58,0	35	60	20	125,06	55,5	20,6	2,5	1,49
		64	322,4	320,0	58,0	35	150	30	27,65	48	25,0	2,5	16,94



KEGELRÄDER MIT GERADEN ZÄHNEN - TYP B

MATERIAL:
Stahl: C43 UNI 7847
EINGRIFFSWINKEL: 20 °

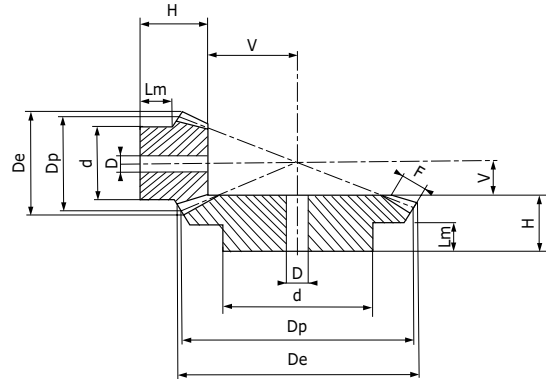

VERHÄLTNIS 1/1											
Modul	Art. Nr.	Z	De	Dp	H	F	d	D	V	Lm	Kg
1	CCB 10 1616	16 / 16	17,4	16,0	11,2	4	13,3	4	4,8	6,5	0,02
	CCB 10 1919	19 / 19	20,4	19,0	11,8	4	15,3	4	6,2	6,5	0,02
	CCB 10 2222	22 / 22	23,4	22,0	12,8	4,7	16,3	5	7,2	6,5	0,02
	CCB 10 2626	26 / 26	27,4	26,0	13,3	5,5	20,3	5	8,7	7	0,04
1,5	CCB 10 3030	30 / 30	31,4	30,0	16,0	4	20,3	5	10,0	8	0,05
	CCB 15 1616	16 / 16	26,1	24,0	18,9	6	20,3	8	7,1	12	0,04
	CCB 15 1919	19 / 19	30,6	28,5	21,3	7	20,3	8	8,7	12	0,05
	CCB 15 2222	22 / 22	35,1	33,0	22,5	7,5	25,3	8	10,5	12	0,09
2	CCB 15 2626	26 / 26	41,1	39,0	23,2	8,5	28,3	8	12,8	12	0,12
	CCB 15 3030	30 / 30	47,1	45,0	27,2	10	30,3	12	14,8	12	0,17
	CCB 20 1616	16 / 16	34,8	32,0	23,5	8	25,3	8	9,5	14	0,08
	CCB 20 1919	19 / 19	40,8	38,0	24,2	9	25,3	8	11,8	12	0,11
2,5	CCB 20 2222	22 / 22	46,8	44,0	27,9	10	30,3	12	14,1	14	0,18
	CCB 20 2626	26 / 26	54,8	52,0	31,4	12	35,3	12	16,6	14	0,28
	CCB 20 3030	30 / 30	62,8	60,0	34,1	13	40,3	14	19,9	17	0,41
	CCB 25 1616	16 / 16	43,5	40,0	28,1	10	30,3	12	11,9	15	0,14
3	CCB 25 1919	19 / 19	51,0	47,5	27,1	11	35,3	12	14,9	13	0,21
	CCB 25 2222	22 / 22	58,5	55,0	30,1	12	45,3	16	17,9	16	0,36
	CCB 25 2626	26 / 26	68,5	65,0	33,2	15	45,3	16	20,8	16	0,47
	CCB 25 3030	30 / 30	78,5	75,0	39,0	16	50,3	16	25,0	20	0,74
3,5	CCB 30 1616	16 / 16	52,5	48,0	31,7	12	40,3	12	14,3	18	0,28
	CCB 30 1919	19 / 19	61,2	57,0	36,0	13	40,3	14	18,0	17	0,39
	CCB 30 2222	22 / 22	70,2	66,0	36,9	15	50,3	16	21,1	17	0,59
	CCB 30 2626	26 / 26	82,2	78,0	38,4	17	50,3	16	25,6	18	0,77
4	CCB 30 3030	30 / 30	94,2	90,0	43,8	19	60,3	20	30,2	22	1,19
	CCB 35 1616	16 / 16	60,9	56,0	36,4	14	45,3	16	16,6	20	0,41
	CCB 35 1919	19 / 19	71,5	66,5	37,8	15	50,3	18	21,0	19	0,59
	CCB 35 2222	22 / 22	81,9	77,0	39,1	17	55,3	20	24,9	18	0,84
4,5	CCB 35 2626	26 / 26	96,0	91,0	43,35	20	62,3	20	29,7	20	1,17
	CCB 35 3030	30 / 30	110,0	105,0	47,1	23	70,3	20	34,9	22	1,69
	CCB 40 1616	16 / 16	69,7	64,0	44,3	15	50,3	16	19,7	25	0,66
	CCB 40 1919	19 / 19	81,7	76,0	44,4	18	55,3	20	23,6	22	0,88
5	CCB 40 2222	22 / 22	93,7	88,0	45,9	20	60,3	20	28,1	22	1,21
	CCB 40 2626	26 / 26	109,7	104,0	48,0	25	70,3	20	34,0	22	1,68
	CCB 40 3030	30 / 30	125,7	120,0	54,2	26	80,3	25	39,8	25	2,50
	CCB 45 1616	16 / 16	78,4	72,0	46,3	17,5	55,3	20	21,7	25	0,84
5	CCB 45 1919	19 / 19	91,8	85,5	49,0	20	62,3	20	26,57	25	1,15
	CCB 45 2222	22 / 22	105,3	99,0	50,1	22	70,3	20	31,9	25	1,72
	CCB 45 2626	26 / 26	123,0	117,0	54,7	25	75,3	20	38,6	26	2,22
	CCB 45 3030	30 / 30	141,4	135,0	60,0	29	80,3	25	45,0	28	3,25
5	CCB 50 1616	16 / 16	87,1	80,0	48,9	18	60,3	20	25,1	25	1,10
	CCB 50 1919	19 / 19	102,1	95,0	52,2	22	60,3	20	29,8	25	1,50
	CCB 50 2222	22 / 22	117,1	110,0	58,2	24	80,3	25	35,8	30	2,39
	CCB 50 2626	26 / 26	137,1	130,0	62,7	29	80,3	25	42,3	30	3,27
CCB 50 3030	30 / 30	157,1	150,0	68,9	32	80,3	30	50,1	35	4,13	

KEGELRÄDER MIT GERADEN ZÄHNEN - TYP B
MATERIAL:

Stahl: C43 UNI 7847

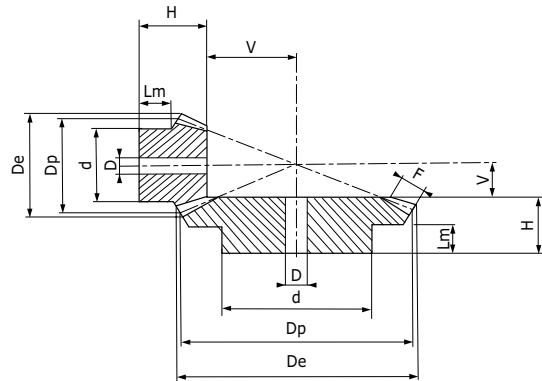
EINGRIFFSWINKEL: 20 °

VERHÄLTNIS 1/2													
Modul	Art. Nr.	Z	De	Dp	H	F	d	D	V	L	Lm	S	Kg
1	CCB 10 1530	15	17,4	15,0	11,9	5	13,3	4	10,1	-	6,5	-	0,02
		30	30,6	30,0	15,1	5	20,3	5	4,9	13,7	9,0	1,4	0,05
1,5	CCB 15 1530	15	26,1	22,5	21,1	9	19,3	8	13,9	-	11,9	-	0,04
		30	45,9	45,0	25,2	9	32,3	8	6,8	23,0	16,0	2,2	0,17
2	CCB 20 1530	15	34,8	30,0	26,0	11,5	25,3	8	19,0	-	14,1	-	0,09
		30	61,2	60,0	29,8	11,5	40,3	14	9,2	26,8	18,0	3,0	0,32
2,5	CCB 25 1530	15	43,5	37,5	31,8	15	32,3	12	23,2	-	16,2	-	0,17
		30	76,5	75,0	33,7	15	45,3	16	11,3	30,0	20,0	3,7	0,50
3	CCB 30 1530	15	52,2	45,0	37,3	17	40,3	12	28,7	-	19,9	-	0,33
		30	91,8	90,0	42,1	17	55,3	16	13,9	38,0	25,0	4,1	0,96
3,5	CCB 35 1530	15	60,9	52,5	46,1	20,5	45,3	16	32,9	-	24,7	-	0,50
		30	107,1	105,0	45,0	20,5	60,3	20	16,0	40,0	25,0	5,0	1,31
4	CCB 40 1530	15	69,6	60,0	48,6	22,5	50,3	20	38,4	-	24,6	-	0,65
		30	122,3	120,0	57,3	22,5	80,3	25	18,7	51,9	35,0	5,4	2,52
4,5	CCB 45 1530	15	78,3	67,5	51,4	26	60,3	20	42,6	-	24,7	-	0,97
		30	137,6	135,0	60,3	26	80,3	30	20,7	54,3	35,0	6,0	2,95
5	CCB 50 1530	15	87,0	75,0	57,6	30	60,3	25	46,4	-	25,3	-	1,23
		30	152,9	150,0	62,5	30	80,3	30	22,5	56,0	35,0	6,5	3,56

VERHÄLTNIS 1/3													
Modul	Art. Nr.	Z	De	Dp	H	F	d	D	V	L	Lm	S	Kg
1	CCB 10 1545	15	17,7	15,0	16,6	7,1	13,3	4	15,4	-	9,2	-	0,02
		45	45,3	45,0	17,1	7,1	25,3	8	4,9	15,2	10,0	1,9	0,09
1,5	CCB 15 1545	15	26,5	22,5	22,6	10,5	19,3	8	23,4	-	11,7	-	0,04
		45	68,1	67,5	29,6	10,5	45,3	14	7,4	34,6	20,0	2,4	0,40
2	CCB 20 1545	15	35,4	30,0	28,9	14,0	25,3	8	31,1	-	14,2	-	0,11
		45	90,8	90,0	32,1	14,0	45,3	16	9,9	28,4	20,0	3,7	0,62
2,5	CCB 25 1545	15	44,1	37,5	34,6	18,0	32,3	12	38,4	-	15,9	-	0,20
		45	113,4	112,5	39,7	18,0	60,3	20	12,3	35,3	25,0	4,4	1,23
3	CCB 30 1545	15	53,0	45,0	41,3	21,0	40,3	16	46,7	-	19,7	-	0,35
		45	136,1	135,0	47,2	21,0	60,3	25	14,8	42,0	30,0	5,2	1,83
3,5	CCB 35 1545	15	61,9	52,5	49,6	23,5	45,3	20	55,4	-	25,0	-	0,57
		45	158,8	157,5	54,4	23,5	80,3	25	17,6	48,6	35,0	5,8	3,21
4	CCB 40 1545	15	70,7	60,0	54,3	27,5	50,3	20	62,7	-	25,4	-	0,75
		45	181,5	180,0	57,0	27,5	80,3	30	20,0	50,5	35,0	6,5	2,53
4,5	CCB 45 1545	15	79,5	67,5	55,2	28,5	55,3	25	72,8	-	24,8	-	1,02
		45	204,2	202,5	63,9	28,5	90,3	30	23,1	57,0	40,0	6,9	5,70
5	CCB 50 1545	15	88,4	75,0	65,3	33,0	60,3	25	79,7	-	30,0	-	1,47
		45	226,9	225,0	66,7	33,0	90,3	30	25,3	59,2	40,0	7,5	7,22

VERHÄLTNIS 1/4													
Modul	Art. Nr.	Z	De	Dp	H	F	d	D	V	L	Lm	S	Kg
1	CCB 10 1560	15	17,8	15,0	17,2	9,3	13,3	4	20,8	-	7,7	-	0,02
		60	60,3	60,0	17,1	9,3	30,3	8	4,9	15,2	10	1,9	0,16
1,5	CCB 15 1560	15	26,7	22,5	23,0	11	20,3	8	34,0	-	11,7	-	0,05
		60	90,4	90,0	34,0	11	50,3	16	8,0	31,2	25	2,8	0,63
2	CCB 20 1560	15	35,6	30,0	31,0	16	25,3	8	44,0	-	14,4	-	0,12
		60	120,6	120,0	37,6	16	60,3	16	10,4	34,2	25	3,4	1,28
2,5	CCB 25 1560	15	44,5	37,5	38,1	19	32,3	14	55,9	-	18,4	-	0,21
		60	150,7	150,0	44,8	19	60,3	20	13,2	40,0	30	4,8	1,92
3	CCB 30 1560	15	53,3	45,0	48,1	23	40,3	16	66,9	-	24,5	-	0,42
		60	180,0	100,8	53,2	23	80,3	25	15,8	48,2	35	5,0	3,75
3,5	CCB 35 1560	15	62,2	52,5	52,1	26	45,3	20	78,9	-	25,1	-	0,62
		60	211,0	210,0	60,4	26	90,3	30	18,6	54,4	40	6,0	5,60
4	CCB 40 1560	15	71,1	60,0	55,1	30	50,3	20	89,9	-	23	-	0,81
		60	241,1	240,0	60,8	30	90,3	30	21,2	53,0	40	7,8	6,43
4,5	CCB 45 1560	15	79,97	67,5	57,0	32	52,3	20	102,9	-	23	-	1,17
		60	271,24	270,0	62,0	32	90,3	30	24,3	53,5	40	8,5	11,30
5	CCB 50 1560	15	88,8	75,0	62,0	34	55,3	20	115,7	-	25	-	1,85
		60	301,3	300,0	65,0	34	90,3	30	27,0	55,0	40	10,0	16,51

sedis 





SPANNSÄTZE

MONTAGEGRUNDLAGEN

KLAA (Seite 180)



Selbst ausrichtend
Einfache Wartung und Montage
Hohes mittleres Drehmoment

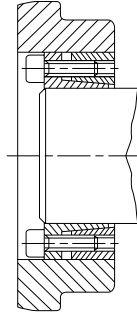

KLAB (Seite 180)



Selbst ausrichtend
Einfache Wartung und Montage
Hohes mittleres Drehmoment

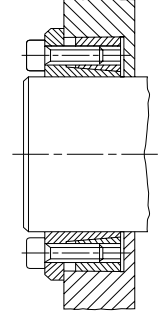

KLBB (Seite 181)



Selbst ausrichtend
Einfache Wartung und Montage
Hohes Drehmoment

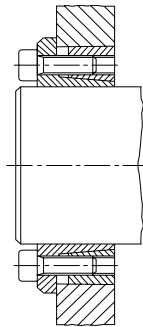

KLCC (Seite 183)



Selbst ausrichtend
Mindest-Radialabmessungen
Einfache Wartung und Montage
Hohes mittleres Drehmoment

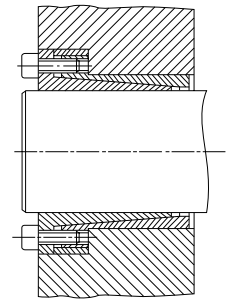

KLDA (Seite 182)



Selbst ausrichtend
Einfache Wartung und Montage
Hohes Drehmoment

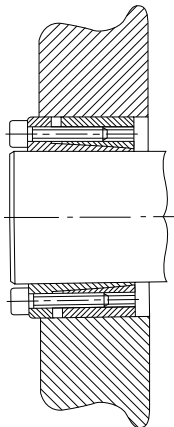

KLDB (Seite 182)



Selbst ausrichtend
Einfache Wartung und Montage
Hohes Drehmoment

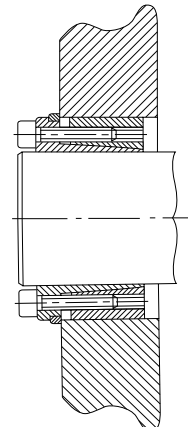

KLEE (Seite 181)



Selbst ausrichtend
Einfache Wartung und Montage
Hohes mittleres Drehmoment

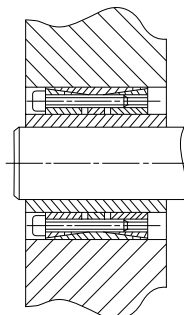

KLFF (Seite 183)



Selbst ausrichtend
Einfache Wartung und Montage
Niedriges mittleres Drehmoment

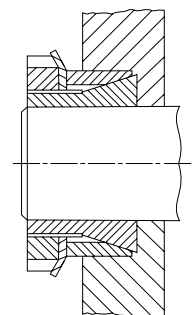



MONTAGEGRUNDLAGEN

KLFC (Seite 187)



Selbst ausrichtend
Einfache Wartung und Montage
Hohes mittleres Drehmoment

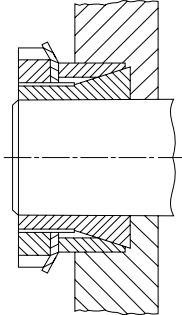

KLGG (Seite 184)



Nicht selbst ausrichtend
Einfache Wartung und Montage
Hohes mittleres Drehmoment

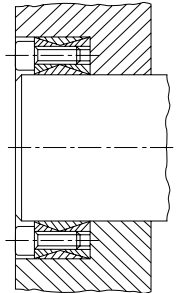

KLHH (Seite 184)



Nicht selbst ausrichtend
Einfache Wartung und Montage
Hohes mittleres Drehmoment

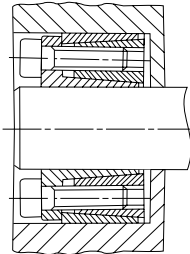

KLMM (Seite 185)



Nicht selbst ausrichtend
Einfache Wartung und Montage
Hohes mittleres Drehmoment

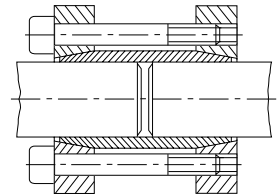

KLNN (Seite 185)



Nicht selbst ausrichtend
Einfache Wartung und Montage
Hohes mittleres Drehmoment

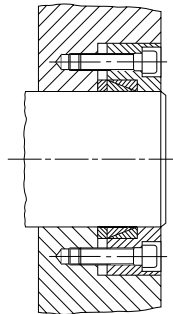

KLPP (Seite 186)



Nicht selbst ausrichtend
Einfache Wartung und Montage
Hohes mittleres Drehmoment

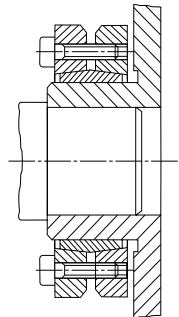

KLRR (Seite 186)



Nicht selbst ausrichtend
Mindest-Radialabmessungen
Einfache Wartung und Montage
Niedriges mittleres Drehmoment

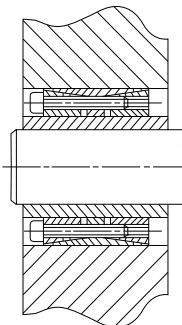

KLSS (Seite 187)



Nicht selbst ausrichtend
Einfache Wartung und Montage
Hohes mittleres Drehmoment

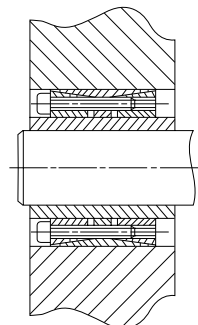

SPANNSÄTZE

KLAA
Selbst ausrichtend
Hohes Drehmoment
Einfache Wartung und Montage

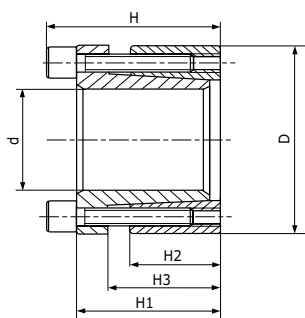

KLAB
Selbst ausrichtend
Hohes Drehmoment
Einfache Wartung und Montage

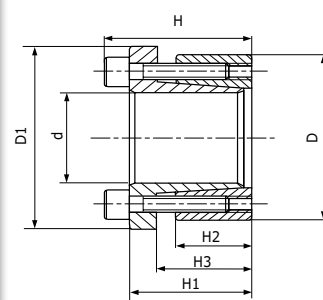

KLAA Art. Nr.	Abmessungen (mm)						Drehmoment (Nm)	Druck (N/mm ²)		Klemmring Drehmoment (Nm)		Schnecke		Kg	
	d	D	H	H1	H2	H3		Welle	Buchse	Typ	Anzahl	Typ	Anzahl		
KLAA019	19	47	34	28	17	22	273	262	106	M6	5	13	M6	3	0,28
KLAA020	20	47	34	28	17	22	287	249	106	M6	5	13	M6	3	0,30
KLAA022	22	47	34	28	17	22	316	227	106	M6	5	13	M6	3	0,35
KLAA024	24	50	34	28	17	22	413	249	120	M6	6	13	M6	3	0,36
KLAA025	25	50	34	28	17	22	431	239	120	M6	6	13	M6	3	0,37
KLAA028	28	55	34	28	17	22	482	213	109	M6	6	13	M6	3	0,38
KLAA030	30	55	34	28	17	22	517	199	109	M6	6	13	M6	3	0,40
KLAA032	32	60	34	28	17	22	734	249	133	M6	8	13	M6	4	0,42
KLAA035	35	60	34	28	17	22	803	227	133	M6	8	13	M6	4	0,44
KLAA038	38	65	34	28	17	22	872	210	122	M6	8	13	M6	4	0,50
KLAA040	40	65	34	28	17	22	918	199	122	M6	8	13	M6	4	0,60
KLAA045	45	75	41	33	20	25	1674	244	146	M8	7	32	M8	3	0,65
KLAA050	50	80	41	33	20	25	1860	219	137	M8	7	32	M8	3	0,70
KLAA055	55	85	41	33	20	25	2340	228	148	M8	8	32	M8	4	0,80
KLAA060	60	90	41	33	20	25	2553	209	139	M8	8	32	M8	4	0,85
KLAA065	65	95	41	33	20	25	3110	217	149	M8	9	32	M8	3	0,90
KLAA070	70	110	50	40	24	30	4838	243	154	M10	8	65	M10	4	1,50
KLAA075	75	115	50	40	24	30	5184	226	148	M10	8	65	M10	4	2,00
KLAA080	80	120	50	40	24	30	5530	212	142	M10	8	65	M10	4	2,20
KLAA085	85	125	50	40	24	30	6610	225	153	M10	9	65	M10	3	2,40
KLAA090	90	130	50	40	24	30	6998	212	147	M10	9	65	M10	3	2,60
KLAA095	95	135	50	40	24	30	8208	223	157	M10	10	65	M10	4	2,80
KLAA100	100	145	56	44	26	32	9742	221	152	M12	8	110	M12	4	3,00
KLAA110	110	155	56	44	26	32	10716	201	143	M12	8	110	M12	4	3,50
KLAA120	120	165	56	44	26	32	13154	207	151	M12	9	110	M12	4	4,00
KLAA130	130	180	64	52	34	40	18996	195	141	M12	12	110	M12	6	4,50
KLAA140	140	190	68	54	34	40	20336	180	133	M14	9	170	M14	4	5,00
KLAA150	150	200	68	54	34	40	24211	187	140	M14	10	170	M14	5	5,40

KLAB Art. Nr.	Abmessungen (mm)							Drehmoment (Nm)	Druck (N/mm ²)		Klemmring Drehmoment (Nm)		Schnecke		Kg	
	d	D	D1	H	H1	H2	H3		Welle	Buchse	Typ	Anzahl	Typ	Anzahl		
KLAB019	19	47	56	34	28	17	22	243	234	94	M6	5	17	M6	3	0,30
KLAB020	20	47	56	34	28	17	22	256	222	94	M6	5	17	M6	3	0,32
KLAB022	22	47	56	34	28	17	22	282	202	94	M6	5	17	M6	3	0,40
KLAB024	24	50	59	34	28	17	22	368	222	106	M6	6	17	M6	3	0,40
KLAB025	25	50	59	34	28	17	22	383	213	106	M6	6	17	M6	3	0,40
KLAB028	28	55	64	34	28	17	22	429	190	97	M6	6	17	M6	3	0,45
KLAB030	30	55	64	34	28	17	22	460	177	97	M6	6	17	M6	3	0,45
KLAB032	32	60	69	34	28	17	22	655	222	118	M6	8	17	M6	4	0,45
KLAB035	35	60	69	34	28	17	22	716	203	118	M6	8	17	M6	4	0,50
KLAB038	38	65	74	34	28	17	22	778	187	109	M6	8	17	M6	4	0,50
KLAB040	40	65	74	34	28	17	22	819	178	109	M6	8	17	M6	4	0,50
KLAB045	45	75	84	41	33	20	25	1458	212	127	M8	7	41	M8	3	0,70
KLAB050	50	80	89	41	33	20	25	1620	191	119	M8	7	41	M8	3	0,70
KLAB055	55	85	94	41	33	20	25	2037	199	129	M8	8	41	M8	4	0,70
KLAB060	60	90	99	41	33	20	25	2223	182	121	M8	8	41	M8	4	0,80
KLAB065	65	95	104	41	33	20	25	2710	189	129	M8	9	41	M8	3	1,00
KLAB070	70	110	119	50	40	24	30	4203	211	134	M10	8	83	M10	4	1,20
KLAB075	75	115	124	50	40	24	30	4754	197	128	M10	8	83	M10	4	1,50
KLAB080	80	120	129	50	40	24	30	4804	184	123	M10	8	83	M10	4	1,80
KLAB085	85	125	134	50	40	24	30	5742	195	133	M10	9	83	M10	3	1,90
KLAB090	90	130	139	50	40	24	30	6080	184	128	M10	9	83	M10	3	2,00
KLAB095	95	135	144	50	40	24	30	7131	194	137	M10	10	83	M10	4	2,20
KLAB100	100	145	154	56	44	26	32	8732	198	137	M12	8	145	M12	4	2,85
KLAB110	110	155	164	56	44	26	32	9605	180	128	M12	8	145	M12	4	3,00
KLAB120	120	165	174	56	44	26	32	11787	186	135	M12	9	145	M12	4	3,50
KLAB130	130	180	189	64	52	34	40	17024	175	126	M12	12	145	M12	6	4,80
KLAB140	140	190	199	68	54	34	40	18703	166	122	M14	9	230	M14	4	5,20
KLAB150	150	200	209	68	54	34	40	22259	172	129	M14	10	230	M14	5	5,85



SPANNSÄTZE

KLBB

Selbst ausrichtend
Hohes Drehmoment
Einfache Wartung und Montage

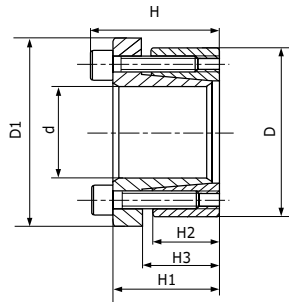

KLEE

Selbst ausrichtend
Hohes Drehmoment
Einfache Wartung und Montage

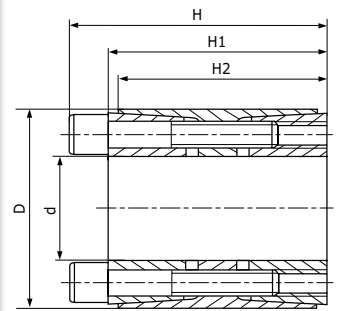

KLBB Art. Nr.	Abmessungen (mm)							Drehmoment (Nm)	Druck (N/mm ²)		Klemmring Drehmoment (Nm)		Schnecke		Kg	
	d	D	D1	H	H1	H2	H3		Welle	Buchse	Typ	Anzahl	Typ	Anzahl		
KLBB114	14	55	63	39	31	17	22	234	415	106	M8	4	37	M8	2	0,50
KLBB116	16	55	63	39	31	17	22	268	363	106	M8	4	37	M8	2	0,50
KLBB118	18	55	63	39	31	17	22	333	357	117	M8	4	41	M8	2	0,50
KLBB119	19	55	63	39	31	17	22	352	338	117	M8	4	41	M8	2	0,50
KLBB120	20	55	63	39	31	17	22	370	321	117	M8	4	41	M8	2	0,50
KLBB122	22	55	63	39	31	17	22	407	292	117	M8	4	41	M8	2	0,50
KLBB124	24	55	63	39	31	17	22	445	268	117	M8	4	41	M8	2	0,50
KLBB125	25	55	63	39	31	17	22	463	257	117	M8	4	41	M8	2	0,50
KLBB128	28	55	63	39	31	17	22	519	229	117	M8	4	41	M8	2	0,50
KLBB130	30	55	63	39	31	17	22	556	214	117	M8	4	41	M8	2	0,50
KLBB224	24	65	72	39	31	17	22	556	335	124	M8	4	41	M8	3	0,75
KLBB225	25	65	72	39	31	17	22	579	321	124	M8	5	41	M8	3	0,75
KLBB228	28	65	72	39	31	17	22	649	287	124	M8	5	41	M8	3	0,75
KLBB230	30	65	72	39	31	17	22	695	268	124	M8	5	41	M8	3	0,75
KLBB232	32	65	72	39	31	17	22	741	251	124	M8	5	41	M8	3	0,75
KLBB233	33	65	72	39	31	17	22	764	242	124	M8	5	41	M8	3	0,75
KLBB235	35	65	72	39	31	17	22	811	230	124	M8	5	41	M8	3	0,75
KLBB238	38	65	72	39	31	17	22	917	211	124	M8	5	41	M8	3	0,75
KLBB240	40	65	72	39	31	17	22	966	201	124	M8	5	41	M8	3	0,75
KLBB330	30	80	87	41	33	20	25	972	318	119	M8	7	41	M8	3	1,00
KLBB332	32	80	87	41	33	20	25	1037	299	119	M8	7	41	M8	3	1,00
KLBB333	33	80	87	41	33	20	25	1069	289	119	M8	7	41	M8	3	1,00
KLBB335	35	80	87	41	33	20	25	1134	273	119	M8	7	41	M8	3	1,00
KLBB338	38	80	87	41	33	20	25	1231	251	119	M8	7	41	M8	3	1,00
KLBB340	40	80	87	41	33	20	25	1296	239	119	M8	7	41	M8	3	1,00
KLBB342	42	80	87	41	33	20	25	1361	227	119	M8	7	41	M8	3	1,00
KLBB345	45	80	87	41	33	20	25	1458	212	119	M8	7	41	M8	3	1,00
KLBB348	48	80	87	41	33	20	25	1555	199	119	M8	7	41	M8	3	1,00
KLBB350	50	80	87	41	33	20	25	1620	191	119	M8	7	41	M8	3	1,00

KLEE Art. Nr.	Abmessungen (mm)					Drehmoment (Nm)	Druck (N/mm ²)		Klemmring Drehmoment (Nm)		Schnecke		Kg	
	d	D	H	H1	H2		Welle	Buchse	Typ	Anzahl	Typ	Anzahl		
KLEE025	25	55	46	40	32	799	314	107	M6	6	17	M6	3	0,50
KLEE028	28	55	46	40	32	895	281	107	M6	6	17	M6	3	0,55
KLEE030	30	55	46	40	32	959	262	107	M6	6	17	M6	3	0,60
KLEE035	35	60	60	54	44	1306	185	83	M6	7	17	M6	3	0,65
KLEE038	38	75	62	54	44	2567	308	212	M8	7	41	M8	3	0,80
KLEE040	40	75	62	54	44	2702	293	121	M8	7	41	M8	3	1,00
KLEE042	42	75	62	54	44	2837	279	121	M8	7	41	M8	3	1,20
KLEE045	45	75	62	54	44	3040	260	121	M8	7	41	M8	3	1,25
KLEE048	48	80	62	54	44	3707	216	102	M8	8	41	M8	3	1,30
KLEE050	50	80	72	64	56	3861	207	102	M8	8	41	M8	3	1,40
KLEE055	55	85	72	64	56	4779	212	108	M8	9	41	M8	3	1,50
KLEE060	60	90	72	64	56	5793	216	113	M8	10	41	M8	4	1,60
KLEE065	65	95	72	64	56	6276	199	107	M8	10	41	M8	4	2,00
KLEE070	70	110	88	78	70	10951	235	120	M10	10	83	M10	4	2,90
KLEE075	75	115	88	78	70	11733	220	115	M10	10	83	M10	4	3,10
KLEE080	80	120	88	78	70	13768	227	121	M10	12	83	M10	4	3,20
KLEE085	85	125	88	78	70	15959	233	127	M10	12	83	M10	5	3,40
KLEE090	90	130	88	78	70	16898	220	122	M10	12	83	M10	5	3,60
KLEE095	95	135	88	78	70	17837	208	117	M10	12	83	M10	5	4,00
KLEE100	100	145	112	100	90	25029	211	113	M12	12	145	M12	4	5,20
KLEE110	110	155	112	100	90	30039	209	115	M12	12	145	M12	5	6,20
KLEE120	120	165	112	100	90	38226	224	127	M12	14	145	M12	5	6,50
KLEE130	130	180	130	116	104	48270	201	117	M14	12	230	M14	5	9,50
KLEE140	140	190	130	116	104	60654	217	129	M14	14	230	M14	7	10,00
KLEE150	150	200	130	116	104	69628	217	132	M14	16	230	M14	7	10,50
KLEE160	160	210	130	116	104	79220	217	134	M14	16	230	M14	7	11,00
KLEE170	170	225	164	148	134	100851	206	116	M16	14	360	M16	7	16,50
KLEE180	180	235	164	148	134	114414	208	119	M16	16	360	M16	7	17,00
KLEE190	190	250	164	148	134	128814	210	119	M16	16	360	M16	7	18,00
KLEE200	200	260	164	148	134	135594	200	115	M16	16	360	M16	7	21,00
KLEE220	220	285	164	148	134	167805	204	118	M16	18	360	M16	8	25,00

SPANNSÄTZE

KLDA
Selbst ausrichtend
Hohes Drehmoment
Einfache Wartung und Montage

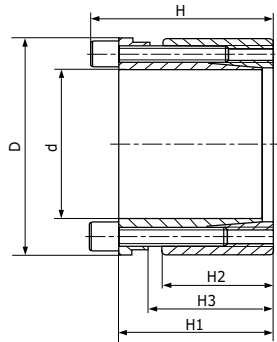

KLDB
Selbst ausrichtend
Hohes Drehmoment
Einfache Wartung und Montage

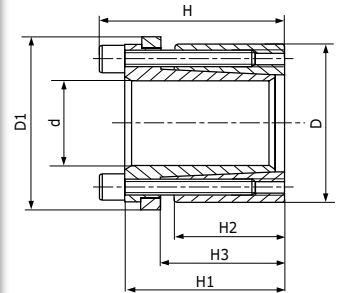

KLDA	Abmessungen (mm)						Drehmoment (Nm)	Druck (N/mm ²)		Klemmring Drehmoment (Nm)		Schnecke		Kg	
	Art. Nr.	d	D	H	H1	H2		H3	Welle	Buchse	Typ	Anzahl	Typ		Anzahl
KLDA019	19	47	45	39	26	31	307	193	78	M6	4	17	M6	2	0,50
KLDA020	20	47	45	39	26	31	323	183	78	M6	4	17	M6	2	0,50
KLDA022	22	47	45	39	26	31	355	166	78	M6	4	17	M6	2	0,50
KLDA024	24	50	45	39	26	31	382	229	110	M6	6	17	M6	3	0,55
KLDA025	25	50	45	39	26	31	606	220	110	M6	6	17	M6	3	0,55
KLDA028	28	55	45	39	26	31	679	196	100	M6	6	17	M6	3	0,60
KLDA030	30	55	45	39	26	31	727	183	100	M6	6	17	M6	3	0,60
KLDA032	32	60	45	39	26	31	1033	229	122	M6	8	17	M6	4	0,65
KLDA035	35	60	45	39	26	31	1130	209	122	M6	8	17	M6	4	0,65
KLDA038	38	65	45	39	26	31	1227	193	113	M6	8	17	M6	4	0,70
KLDA040	40	65	45	39	26	31	1292	183	113	M6	8	17	M6	4	0,80
KLDA042	42	75	55	47	30	36	1835	204	115	M8	6	41	M8	3	1,00
KLDA045	45	75	55	47	30	36	1966	191	115	M8	6	41	M8	3	1,10
KLDA048	48	80	55	47	30	36	2097	179	107	M8	6	41	M8	3	1,20
KLDA050	50	80	55	47	30	36	2184	172	107	M8	6	41	M8	3	1,20
KLDA055	55	85	55	47	30	36	3202	208	135	M8	8	41	M8	4	1,30
KLDA060	60	90	55	47	30	36	3493	191	127	M8	8	41	M8	4	1,40
KLDA065	65	95	55	47	30	36	3784	176	120	M8	8	41	M8	4	1,50
KLDA070	70	110	67	57	40	46	6607	199	127	M10	8	83	M10	4	2,00
KLDA075	75	115	72	62	40	46	7079	186	121	M10	8	83	M10	4	2,60
KLDA080	80	120	72	62	40	46	7551	174	116	M10	8	83	M10	4	2,80
KLDA085	85	125	72	62	40	46	10029	205	139	M10	10	83	M10	4	3,00
KLDA090	90	130	72	62	40	46	10619	193	134	M10	10	83	M10	4	3,20
KLDA095	95	135	72	62	40	46	11209	183	129	M10	10	83	M10	4	3,50
KLDA100	100	145	89	77	46	52	13738	176	121	M12	8	145	M12	4	4,70
KLDA110	110	155	89	77	46	52	15111	160	114	M12	8	145	M12	4	5,00
KLDA120	120	165	89	77	46	52	20606	183	133	M12	10	145	M12	4	5,50
KLDA130	130	180	89	77	46	52	26788	203	147	M12	12	145	M12	4	6,80
KLDA140	140	190	98	84	51	59	26142	154	114	M14	8	230	M14	4	7,50
KLDA150	150	200	98	84	51	59	35016	180	135	M14	10	230	M14	5	8,00

KLDB	Abmessungen (mm)							Drehmoment (Nm)	Druck (N/mm ²)		Klemmring Drehmoment (Nm)		Schnecke		Kg	
	Art. Nr.	d	D	D1	H	H1	H2		H3	Welle	Buchse	Typ	Anzahl	Typ		Anzahl
KLDB019	19	47	53	45	39	26	31	202	127	51	M6	4	17	M6	2	0,40
KLDB020	20	47	53	45	39	26	31	213	121	51	M6	4	17	M6	2	0,45
KLDB022	22	47	53	45	39	26	31	234	110	51	M6	4	17	M6	2	0,50
KLDB024	24	50	56	45	39	26	31	384	151	73	M6	6	17	M6	3	0,55
KLDB025	25	50	56	45	39	26	31	400	145	73	M6	6	17	M6	3	0,60
KLDB028	28	55	61	45	39	26	31	448	129	66	M6	6	17	M6	3	0,65
KLDB030	30	55	61	45	39	26	31	480	121	66	M6	6	17	M6	3	0,70
KLDB032	32	60	66	45	39	26	31	683	151	81	M6	8	17	M6	4	0,80
KLDB035	35	60	66	45	39	26	31	747	138	81	M6	8	17	M6	4	0,85
KLDB038	38	65	71	45	39	26	31	811	127	74	M6	8	17	M6	4	0,90
KLDB040	40	65	71	45	39	26	31	853	121	74	M6	8	17	M6	4	0,95
KLDB042	42	75	81	55	47	30	36	1216	135	76	M8	6	41	M8	3	1,00
KLDB045	45	75	81	55	47	30	36	1302	126	76	M8	6	41	M8	3	1,20
KLDB048	48	80	86	55	47	30	36	1389	119	71	M8	6	41	M8	3	1,40
KLDB050	50	80	86	55	47	30	36	1447	114	71	M8	6	41	M8	3	1,50
KLDB055	55	85	91	55	47	30	36	2124	138	89	M8	8	41	M8	4	1,65
KLDB060	60	90	96	55	47	30	36	2317	127	84	M8	8	41	M8	4	1,80
KLDB065	65	95	101	55	47	30	36	2510	117	80	M8	8	41	M8	4	2,10
KLDB070	70	110	116	67	57	40	46	4381	132	84	M10	8	83	M10	4	2,30
KLDB075	75	115	121	72	62	40	46	4694	123	80	M10	8	83	M10	4	2,55
KLDB080	80	120	126	72	62	40	46	5007	115	77	M10	8	83	M10	4	2,70
KLDB085	85	125	131	72	62	40	46	6651	136	92	M10	10	83	M10	4	2,85
KLDB090	90	130	136	72	62	40	46	7042	128	89	M10	10	83	M10	4	3,00
KLDB095	95	135	141	72	62	40	46	7433	121	85	M10	10	83	M10	4	3,20
KLDB100	100	145	151	89	77	46	52	9104	117	81	M12	8	145	M12	4	4,50
KLDB110	110	155	161	89	77	46	52	10015	106	75	M12	8	145	M12	4	5,50
KLDB120	120	165	171	89	77	46	52	13653	122	88	M12	10	145	M12	4	6,00
KLDB130	130	180	186	89	77	46	52	17747	135	97	M12	12	145	M12	4	7,00
KLDB140	140	190	196	90	84	51	59	17328	102	75	M14	8	230	M14	4	8,00
KLDB150	150	200	206	90	84	51	59	23207	119	89	M14	10	230	M14	5	9,00



SPANNSÄTZE

KLCC

Selbst ausrichtend
Mindest-Radialabmessungen
Einfache Wartung und Montage
Hohes mittleres Drehmoment

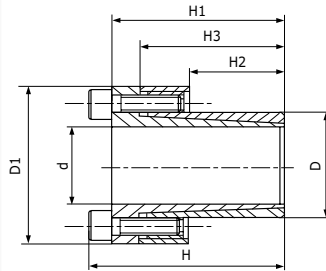

KLFF

Selbst ausrichtend
Mindest-Radialabmessungen
Einfache Wartung und Montage
Niedriges mittleres Drehmoment

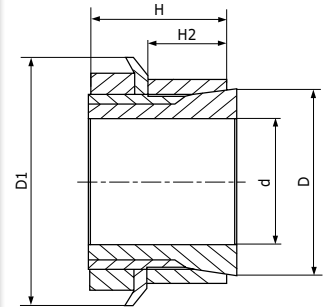

KLCC Art. Nr.	Abmessungen (mm)							Drehmoment (Nm)	Druck (N/mm ²)			Klemmring Drehmoment			Schnecke		Kg
	d	D	D1	H	H1	H2	H3		Welle	Buchse	Typ	Anzahl	(Nm)	Typ	Anzahl		
KLCC006	6	14	27	26	23	10	19	12	190	80	M3	3	2,2	M3	2	0,04	
KLCC008	8	15	32	28	24	12	21	39	299	159	M4	3	4,81	M4	2	0,06	
KLCC009	9	16	32	31	27	14	23	44	227	128	M4	3	5,2	M4	3	0,10	
KLCC010	10	16	32	31	27	14	23	49	205	128	M4	3	5,2	M4	3	0,10	
KLCC011	11	18	34	31	27	14	23	53	186	114	M4	4	5,2	M4	3	0,10	
KLCC012	12	18	34	31	27	14	23	58	171	114	M4	4	5,2	M4	3	0,20	
KLCC014	14	23	39	31	27	14	23	68	146	89	M4	4	5,2	M4	3	0,20	
KLCC015	15	24	45	42	36	16	29	120	196	12	M6	4	17	M6	2	0,25	
KLCC016	16	24	45	42	36	16	29	128	184	123	M6	4	17	M6	2	0,30	
KLCC018	18	26	47	44	38	18	31	191	194	134	M6	4	17	M6	3	0,35	
KLCC019	19	27	48	44	38	18	31	202	183	129	M6	4	17	M6	3	0,35	
KLCC020	20	28	49	44	38	18	31	213	174	124	M6	4	17	M6	3	0,40	
KLCC022	22	32	54	51	45	25	38	234	114	78	M6	4	17	M6	3	0,40	
KLCC024	24	34	56	51	45	25	38	255	105	74	M6	4	17	M6	3	0,50	
KLCC025	25	34	56	51	45	25	38	266	100	74	M6	4	17	M6	3	0,55	
KLCC028	28	39	61	81	45	25	38	373	112	81	M6	6	17	M6	3	0,60	
KLCC030	30	41	63	51	45	25	38	480	126	92	M6	6	17	M6	3	0,65	
KLCC032	32	43	65	56	50	30	43	511	98	73	M6	6	17	M6	3	0,65	
KLCC035	35	47	69	56	50	30	43	747	120	89	M6	8	17	M6	4	0,70	
KLCC038	38	50	72	56	50	30	43	811	110	84	M6	8	17	M6	4	0,75	
KLCC040	40	53	75	58	52	32	45	959	110	83	M6	8	17	M6	4	0,80	
KLCC042	42	55	77	58	52	32	45	1007	105	80	M8	8	17	M8	4	0,85	
KLCC045	45	59	85	72	64	40	56	1781	130	99	M8	8	42	M8	4	1,00	
KLCC048	48	62	88	72	64	40	56	1900	122	94	M8	8	42	M8	4	1,20	
KLCC050	50	65	92	82	74	50	66	2473	117	90	M8	10	42	M8	5	1,40	
KLCC055	55	71	98	82	74	50	66	2721	106	82	M8	10	42	M8	5	1,50	
KLCC060	60	77	104	82	74	50	66	2968	97	76	M8	10	42	M8	5	1,70	
KLCC065	65	84	111	82	74	50	66	3215	90	69	M10	10	42	M10	5	2,00	
KLCC070	70	90	122	101	91	60	80	4430	89	69	M10	10	84	M10	4	3,00	
KLCC075	75	95	126	101	91	60	80	5338	93	74	M10	10	84	M10	4	3,10	
KLCC080	80	100	131	106	96	65	85	7595	108	86	M10	12	84	M10	5	3,40	
KLCC090	90	112	143	106	96	65	85	9968	112	90	M10	12	84	M10	6	4,00	
KLCC095	95	120	153	106	96	65	85	10522	106	84	M12	12	84	M12	6	4,50	
KLCC100	100	125	162	114	102	65	89	13651	124	99	M12	12	145	M12	5	5,50	
KLCC110	110	140	177	119	107	70	94	15016	105	82	M12	14	145	M12	5	7,50	
KLCC120	120	155	195	139	127	90	114	21844	99	77	M12	18	145	M12	7	10,30	
KLCC130	130	165	205	139	127	90	114	23664	92	72	M12	18	145	M12	7	11,00	
KLCC140	140	175	215	139	127	90	114	25485	85	68	M12	18	145	M12	7	12,00	
KLCC150	150	185	225	139	127	90	114	27305	80	64	M12	18	145	M12	7	14,00	

KLFF Art. Nr.	Abmessungen (mm)						Drehmoment (Nm)	Druck (N/mm ²)		Klemmring Drehmoment		Kg
	d	D	D1	H	H2	Welle		Buchse	Typ	(Nm)		
KLFF015	15	25	32	31	23	77	91	55	M20 x 1,0	95	0,10	
KLFF018	18	30	38	33	24	125	98	59	M25 x 1,5	160	0,20	
KLFF019	19	30	38	33	24	132	93	59	M25 x 1,5	160	0,30	
KLFF020	20	30	38	33	24	139	88	9	M25 x 1,5	160	0,30	
KLFF024	24	35	45	38	29	202	74	51	M30 x 1,5	220	0,40	
KLFF025	25	35	45	38	29	210	71	51	M30 x 1,5	220	0,40	
KLFF028	28	40	52	44	34	312	76	53	M35 x 1,5	340	0,40	
KLFF030	30	40	52	44	34	335	71	53	M35 x 1,5	340	0,50	
KLFF035	35	45	58	45	34	483	75	58	M40 x 1,5	480	0,50	
KLFF040	40	50	65	46	35	696	82	66	M45 x 1,5	680	0,60	
KLFF045	45	55	70	47	35	902	84	69	M50 x 1,5	870	0,60	
KLFF050	50	60	75	48	36	1014	77	64	M55 x 2,0	970	0,65	
KLFF055	55	65	80	48	36	1158	73	61	M60 x 2,0	1100	0,70	
KLFF060	60	70	85	50	36	1379	73	62	M65 x 2,0	1300	0,70	

SPANNSÄTZE
KLGG

Nicht selbst ausrichtend
Einfache Wartung und Montage
Hohes mittleres Drehmoment

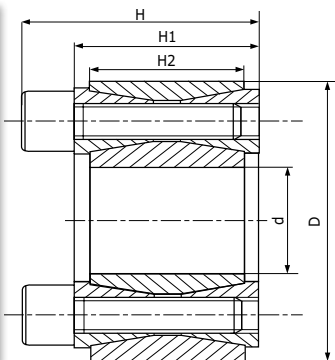
KLHH

Nicht selbst ausrichtend
Einfache Wartung und Montage
Niedriges mittleres Drehmoment

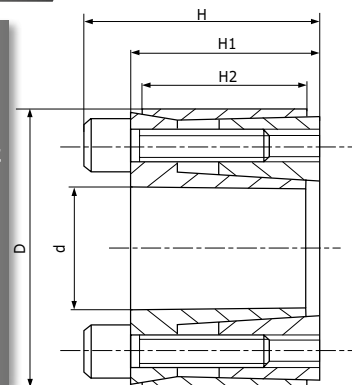

KLGG	Abmessungen (mm)					Drehmoment (Nm)	Druck (N/mm ²)		Klemmring Drehmoment (Nm)			Schnecke		Kg
	Art. Nr.	d	D	H	H1		H2	Welle	Buchse	Typ	Anzahl	Drehmoment (Nm)	Typ	
KLGG019	19	47	26	20	17	298	286	116	M6	8	14,9	M8	2	0,30
KLGG020	20	47	26	20	17	313	272	116	M6	8	14,9	M8	2	0,35
KLGG022	22	47	26	20	17	345	247	116	M6	8	14,9	M8	2	0,40
KLGG024	24	50	26	20	17	424	255	123	M6	9	14,9	M8	3	0,45
KLGG025	25	50	26	20	17	441	245	123	M6	9	14,9	M8	3	0,45
KLGG028	28	55	26	20	17	549	243	124	M6	10	14,9	M8	3	0,50
KLGG030	30	55	26	20	17	588	227	124	M6	10	14,9	M8	3	0,55
KLGG032	32	60	26	20	17	758	255	136	M6	12	14,9	M8	4	0,60
KLGG035	35	60	26	20	17	822	233	136	M6	12	14,9	M8	4	0,65
KLGG038	38	65	26	20	17	1042	250	146	M6	14	14,9	M8	4	0,70
KLGG040	40	65	26	20	17	1097	238	146	M6	14	14,9	M8	4	0,75
KLGG042	42	75	32	24	20	1740	291	163	M8	12	35	M10	4	0,80
KLGG045	45	75	32	24	20	1864	271	163	M8	12	35	M10	4	0,85
KLGG048	48	80	32	24	20	1988	254	153	M8	12	35	M10	4	0,90
KLGG050	50	80	32	24	20	2071	244	153	M8	12	35	M10	4	1,00
KLGG055	55	85	32	24	20	2658	259	168	M8	14	35	M10	4	1,20
KLGG060	60	90	32	24	20	2900	238	158	M8	14	35	M10	4	1,30
KLGG065	65	95	32	24	20	3587	250	171	M8	16	35	M10	4	1,40
KLGG070	70	110	38	28	24	5345	268	171	M10	14	69	M12	4	1,50
KLGG075	75	115	38	28	24	5727	250	163	M10	14	69	M12	4	1,60
KLGG080	80	120	38	28	24	6108	235	156	M10	14	69	M12	4	1,60
KLGG085	85	125	38	28	24	7417	252	172	M10	16	69	M12	4	1,70
KLGG090	90	130	38	28	24	7854	238	165	M10	16	69	M12	4	1,70
KLGG095	95	135	38	28	24	9326	254	179	M10	18	69	M12	4	1,90
KLGG100	100	145	45	33	26	11362	258	178	M12	14	123,3	M14	4	2,20
KLGG110	110	155	45	33	26	12498	234	166	M12	14	123,3	M14	4	2,40
KLGG120	120	165	45	33	26	15578	245	178	M12	16	123,3	M14	4	2,50
KLGG130	130	180	50	38	34	21095	217	156	M12	20	123,3	M14	4	3,50
KLGG140	140	190	50	38	34	24993	221	163	M12	22	123,3	M14	4	3,70
KLGG150	150	200	50	38	34	29217	225	169	M12	24	123,3	M14	4	4,00
KLGG160	160	210	50	38	34	33756	229	174	M12	26	123,3	M14	4	4,20
KLGG170	170	225	58	44	38	39483	212	160	M14	22	187	M16	4	5,50
KLGG180	180	235	58	44	38	45606	218	167	M14	24	187	M16	4	6,00
KLGG190	190	250	66	52	46	56163	199	152	M14	28	187	M16	4	8,00
KLGG200	200	260	66	52	46	63342	203	156	M14	30	187	M16	4	9,00

KLHH	Abmessungen (mm)					Drehmoment (Nm)	Druck (N/mm ²)		Klemmring Drehmoment (Nm)			Schnecke		Kg
	Art. Nr.	d	D	H	H1		H2	Welle	Buchse	Typ	Anzahl	Drehmoment (Nm)	Typ	
KLHH019	19	41	24,5	18,5	12	174	176	81	M6	6	17	M8	2	0,10
KLHH020	20	42	24,5	18,5	12	183	167	79	M6	6	17	M8	2	0,20
KLHH024	24	46	24,5	18,5	12	329	209	109	M6	6	17	M8	2	0,30
KLHH025	25	47	24,5	18,5	12	343	200	106	M6	8	17	M8	2	0,30
KLHH028	28	50	24,5	18,5	12	384	179	100	M6	8	17	M8	2	0,35
KLHH030	30	52	24,5	18,5	12	412	167	96	M6	8	17	M8	2	0,40
KLHH035	35	57	28	22	15	480	117	78	M6	12	17	M8	3	0,40
KLHH038	38	60	28	22	15	695	143	91	M6	12	17	M8	3	0,45
KLHH040	40	62	28	22	15	732	136	88	M6	12	17	M8	3	0,45
KLHH042	42	70	36	28	18	1427	185	111	M8	12	42	M10	3	0,50
KLHH045	45	73	36	28	18	1529	172	106	M8	12	42	M10	3	0,55
KLHH048	48	76	36	28	18	1631	161	102	M8	12	42	M10	3	0,60
KLHH050	50	78	36	28	18	1699	155	99	M8	12	42	M10	3	0,70
KLHH055	55	83	36	28	18	1869	141	93	M8	16	42	M10	4	0,80
KLHH060	60	88	36	28	18	2039	129	88	M8	16	42	M10	4	0,90
KLHH070	70	105	45	35	22	3759	137	91	M8	16	83	M10	4	1,00
KLHH080	80	115	45	35	22	4296	120	83	M10	16	83	M12	3	1,30



SPANNSÄTZE

KLMM

Nicht selbst ausrichtend
Einfache Wartung und Montage
Hohes mittleres Drehmoment

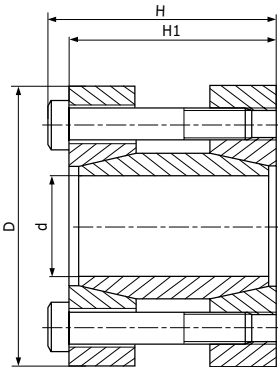

KLNN

Nicht selbst ausrichtend
Mindest-Radialabmessungen
Einfache Wartung und Montage
Niedriges mittleres Drehmoment

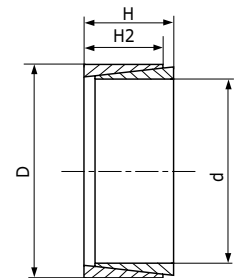

KLMM	Abmessungen (mm)				Drehmoment (Nm)	Druck (N/mm ²) Welle	Klemmring		Kg	
	Art. Nr.	d	D	H1			H	Typ		Anzahl
KLMM017	17	50	50	56	179	166	M6	4	17	0,45
KLMM018	18	50	50	56	190	157	M6	4	17	0,50
KLMM019	19	50	50	56	200	149	M6	4	17	0,55
KLMM020	20	50	50	56	211	141	M6	4	17	0,60
KLMM024	24	55	60	66	378	144	M6	4	17	0,70
KLMM025	25	55	60	66	394	138	M6	6	17	0,85
KLMM028	28	60	60	66	442	123	M6	6	17	0,85
KLMM030	30	60	60	66	473	115	M6	6	17	0,85
KLMM032	32	63	60	66	505	108	M6	6	17	0,90
KLMM035	35	75	75	83	682	98	M8	4	42	1,00
KLMM038	38	75	75	83	741	90	M8	4	42	1,10
KLMM040	40	75	75	83	780	86	M8	4	42	1,20
KLMM042	42	78	75	83	819	82	M8	4	42	1,40
KLMM045	45	85	85	93	1317	101	M8	6	42	2,00
KLMM048	48	90	85	93	1405	95	M8	6	42	2,20
KLMM050	50	90	85	93	1463	91	M8	6	42	2,30
KLMM055	55	94	85	93	2147	110	M8	8	42	2,40
KLMM060	60	100	85	93	2343	101	M8	8	42	2,50
KLMM065	65	105	85	93	2538	93	M8	8	42	3,00
KLMM070	70	115	100	110	4321	116	M10	6	85	3,80

KLNN	Abmessungen (mm)				Drehmoment (Nm)	Kraft erforderlich KN	Druck (N/mm ²)		Kg
	Art. Nr.	d	D	H			H2	Welle	
KLNN008	8	11	4,5	3,7	4,2	1,06	100	70	0,001
KLNN010	10	13	4,5	3,7	7,6	1,53	100	86	0,002
KLNN012	12	15	4,5	3,7	9,9	1,65	100	80	0,003
KLNN014	14	18	6,3	5,3	18,9	2,7	100	77	0,004
KLNN015	15	19	6,3	5,3	22,1	2,94	100	79	0,005
KLNN016	16	20	6,3	5,3	25,4	3,18	100	81	0,010
KLNN018	18	22	6,3	5,3	31,8	3,53	100	82	0,020
KLNN019	19	24	6,3	5,3	35,8	3,76	100	80	0,030
KLNN020	20	25	6,3	5,3	38,8	3,88	100	79	0,030
KLNN022	22	26	6,3	5,3	47,9	4,35	100	86	0,040
KLNN024	24	28	6,3	5,3	56,4	4,7	100	86	0,040
KLNN025	25	30	6,3	5,3	61,7	4,94	100	84	0,045
KLNN028	28	32	6,3	5,3	77,4	5,53	100	88	0,045
KLNN030	30	35	6,3	5,3	88,2	5,88	100	86	0,045
KLNN032	32	36	6,3	5,3	100	6,23	100	88	0,050
KLNN035	35	40	7	6	136	7,76	100	88	0,050
KLNN038	38	44	7	6	161	8,47	100	87	0,050
KLNN040	40	45	8	6,6	195	9,8	100	89	0,050
KLNN042	42	48	8	6,6	215	10,2	100	87	0,050
KLNN045	45	52	10	8,6	323	14,3	100	87	0,050
KLNN048	48	55	10	8,6	367	15,3	100	88	0,050
KLNN050	50	57	10	8,6	397	15,9	100	88	0,100
KLNN055	55	62	10	8,6	479	17,4	100	88	0,100
KLNN060	60	68	12	10,4	691	23	100	88	0,100
KLNN065	65	73	12	10,4	814	25	100	89	0,150
KLNN070	70	79	14	12,2	1107	31,6	100	89	0,150
KLNN075	75	84	14	12,2	1266	33,8	100	89	0,150
KLNN080	80	91	17	15	1769	44,2	100	89	0,200
KLNN090	90	101	17	15	2244	49,9	100	89	0,200
KLNN100	100	114	21	18,7	3452	69	100	89	0,300
KLNN110	110	124	21	18,7	4178	76	100	89	0,400
KLNN120	120	134	21	18,7	4967	82,8	100	89	0,600
KLNN130	130	148	28	25,3	7896	121	100	89	0,800
KLNN140	140	158	28	25,3	9146	131	100	89	1,000
KLNN150	150	168	28	25,3	10505	140	100	89	1,200

SPANNSÄTZE
KLPP

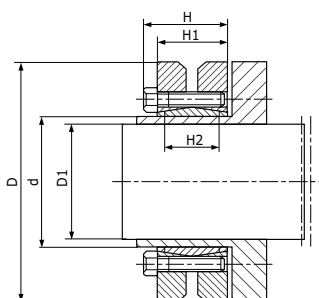
 Nicht selbst ausrichtend
 Einfache Wartung und Montage
 Hohes mittleres Drehmoment

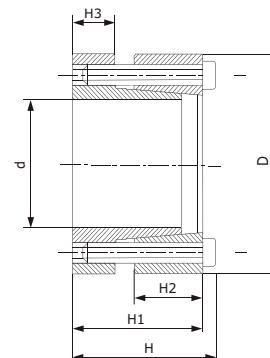
KLRR

 Nicht selbst ausrichtend
 Einfache Wartung und Montage
 Hohes mittleres Drehmoment

KLPP	Abmessungen (mm)						Drehmoment (Nm)	Druck (N/mm ²) Welle	Klemmring		Kg	
	Art. Nr.	d	D	D1	H	H1			H2	Typ		Anzahl
KLPP024	24	50	20 21	23	19,5	14	265 314	286	M5	6	4	0,20
KLPP030	30	60	24 25 26	25	21,5	16	372 421 461	233	M5	7	4	0,30
KLPP036	36	72	28 30 31	27,5	23,5	18	471 550 713	307	M6	5	12	0,50
KLPP044	44	80	32 35 36	29,5	25,5	20	925 1175 1275	317	M6	7	12	0,60
KLPP050	50	90	38 40 42	31,5	27,5	22	1313 1638 1925	289	M6	8	12	0,90
KLPP055	55	100	42 45 48	34,5	30,5	23	1450 1900 2350	252	M6	8	12	1,20
KLPP062	62	110	48 50 52	34,5	30,5	23	2775 3275 3613	279	M6	10	12	1,30
KLPP068	68	115	50 55 60	34,5	30,5	23	2500 3125 3938	255	M6	10	12	1,40
KLPP075	75	138	55 60 65	37,8	32,5	25	3125 4000 4938	273	M8	7	30	2,00
KLPP080	80	145	60 65 70	37,8	32,5	25	4000 4875 5750	256	M8	7	30	2,60
KLPP090	90	155	65 70 75	44,3	39	30	5938 7500 9063	271	M8	10	30	3,50
KLPP100	100	170	70 75 80	49,3	44	34	8625 9375 11250	258	M8	12	30	4,50
KLPP110	110	185	75 80 85	56,4	50	39	9000 11250 13500	244	M10	9	59	6,10
KLPP125	125	215	85 90 95	60,4	54	42	13750 16250 18750	266	M10	12	59	8,85
KLPP140	140	230	95 100 105	68	60,5	46	18875 22000 25125	264	M12	10	100	10,90
KLPP155	155	263	105 110 115	72	64,5	50	27500 31250 35000	263	M12	12	100	16,00
KLPP165	165	290	115 120 125	81	71	56	38750 43750 48750	277	M16	8	100	22,00

KLRR	Abmessungen (mm)						Drehmoment (Nm)	Druck (N/mm ²)		Klemmring		Schnecke		
	Art. Nr.	d	D	H3	H1	H		H2	Welle	Buchse	Typ	Anzahl	Drehmoment (Nm)	Typ
KLRR020	20	47	10	28	34	14	294	328	139	M6x25	5	13	M6x25	3
KLRR022	22	47	10	28	34	14	323	298	139	M6x25	5	13	M6x25	3
KLRR024	24	50	10	28	34	14	455	353	169	M6x25	6	14	M6x25	3
KLRR025	25	50	10	28	34	14	474	338	169	M6x25	6	14	M6x25	3
KLRR030	30	55	10	28	34	14	569	282	154	M6x25	6	14	M6x25	3
KLRR035	35	60	10	28	34	14	885	322	188	M6x25	8	14	M6x25	4
KLRR038	38	65	10	28	34	14	961	297	174	M6x25	8	14	M6x25	4
KLRR040	40	65	10	28	34	14	1012	282	174	M6x25	8	14	M6x25	4
KLRR042	42	75	12	35	43	18	1594	313	176	M8x30	7	32	M8x30	4
KLRR045	45	75	12	35	43	18	1707	293	176	M8x30	7	32	M8x30	4
KLRR050	50	80	12	35	43	18	1897	263	165	M8x30	7	32	M8x30	4
KLRR055	55	85	12	35	43	18	2387	274	177	M8x30	8	32	M8x30	4
KLRR060	60	90	12	35	43	18	2604	251	167	M8x30	8	32	M8x30	4
KLRR065	65	95	12	35	43	18	3172	260	178	M8x30	9	32	M8x30	4
KLRR070	70	110	16	46	56	24	4937	262	167	M10x40	8	65	M10x40	4



SPANNSÄTZE

KLSS

Nicht selbst ausrichtend
Mindest-Radialabmessungen
Einfache Wartung und Montage
Niedriges mittleres Drehmoment

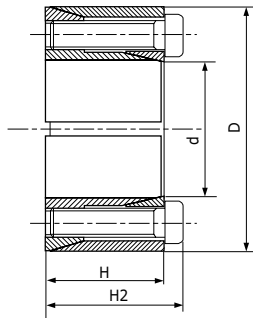

KLFC

Selbst ausrichtend
Einfache Wartung und Montage
Niedriges mittleres Drehmoment

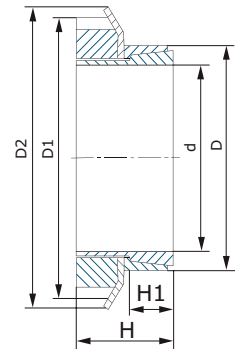

KLSS	Abmessungen (mm)				Drehmoment (Nm)	Druck (N/mm ²)		Klemmring Drehmoment			Schnecke	
	Art. Nr.	d	D	H		H2	Welle	Buchse	Typ	Anzahl	(Nm)	Typ
KLSS010	10	20	13	15,5	19	89	45	M2,5x12	4	1,2	M2,5x12	2
KLSS011	11	22	13	15,5	21	81	41	M2,5x12	4	1,2	M2,5x12	2
KLSS012	12	22	13	15,5	23	75	41	M2,5x12	4	1,2	M2,5x12	2
KLSS014	14	26	17	20	39	71	38	M3x16	4	2,1	M3x16	2
KLSS015	15	28	17	20	42	66	35	M3x16	4	2,1	M3x16	2
KLSS016	16	32	17	21	77	107	54	M4x16	4	4,9	M4x16	2
KLSS017	17	35	21	25	82	81	40	M4x20	4	4,9	M4x20	2
KLSS018	18	35	21	25	87	77	40	M4x20	4	4,9	M4x20	2
KLSS019	19	35	21	25	91	73	40	M4x20	4	4,9	M4x20	2
KLSS020	20	38	21	26	157	113	60	M5x20	4	10	M5x30	2
KLSS022	22	40	21	26	173	103	57	M5x20	4	10	M5x20	2
KLSS024	24	47	26	32	268	110	56	M6x24	4	17	M6x24	2
KLSS025	25	47	26	32	279	105	56	M6x24	4	17	M6x24	2
KLSS028	28	50	26	32	468	141	79	M6x24	6	17	M6x24	3
KLSS030	30	55	26	32	502	132	72	M6x24	6	17	M6x24	3
KLSS032	32	55	26	32	535	123	72	M6x24	6	17	M6x24	3
KLSS035	35	60	31	37	781	125	73	M6x28	8	17	M6x28	4
KLSS038	38	65	31	37	848	115	67	M6x28	8	17	M6x28	4
KLSS040	40	65	31	37	892	110	67	M6x28	8	17	M6x28	4
KLSS042	42	75	36	44	1272	122	68	M8x34	6	41	M8x34	3
KLSS045	45	75	36	44	1363	113	68	M8x34	6	41	M8x34	3
KLSS048	48	80	36	44	1938	142	85	M8x34	8	41	M8x34	4
KLSS050	50	80	36	44	2019	136	85	M8x34	8	41	M8x34	4

KLFC	Abmessungen (mm)						Drehmoment (Nm)	Druck (N/mm ²)		Klemmring Drehmoment		Kg
	Art. Nr.	d	D	D1	H	H1		D2	Welle	Buchse	Typ	
KLFC014	14	25	32	17	6,5	34	52	241	135	M20x1	95	0,30
KLFC015	15	25	32	17	6,5	34	56	225	135	M20x1	95	0,40
KLFC016	16	25	32	17	6,5	34	60	211	135	M20x1	95	0,50
KLFC018	18	30	38	17,5	6,5	41	91	256	154	M25x1,5	160	0,60
KLFC019	19	30	38	18	6,5	41	96	242	154	M25x1,5	160	0,70
KLFC020	20	30	38	18	6,5	41	102	230	154	M25x1,5	160	0,80
KLFC024	24	35	45	18	6,5	48	139	218	150	M30x1,5	220	0,90
KLFC025	25	35	45	18	6,5	48	144	210	150	M30x1,5	220	1
KLFC028	28	40	52	18	6,5	55	215	248	174	M35x1,5	340	1,2
KLFC030	30	40	52	20	8	55	230	188	141	M35x1,5	340	1,3
KLFC035	35	45	58	22	8	61	331	199	155	M40x1,5	480	1,4
KLFC040	40	50	65	25	10	67	477	176	141	M45x1,5	680	1,5
KLFC045	45	55	70	26	10	73	617	180	147	M50x1,5	870	1,6
KLFC048	48	60	75	26	10	81	669	171	137	M55x2	970	1,7
KLFC050	50	60	75	26	10	81	697	164	137	M55x2	970	1,8
KLFC055	55	65	80	27	12	87	796	129	109	M60x2	1100	2
KLFC060	60	70	85	29	12	93	946	129	111	M65x2	1300	2,20
KLFC070	70	84	98	31,5	13,5	104	1433	128	106	M75x2	2000	2,40

sedis 





KUPPLUNGEN

STERNKUPPLUNGEN

MATERIAL:
Guss EN-GJL-200 UNI EN 1561
Aluminium

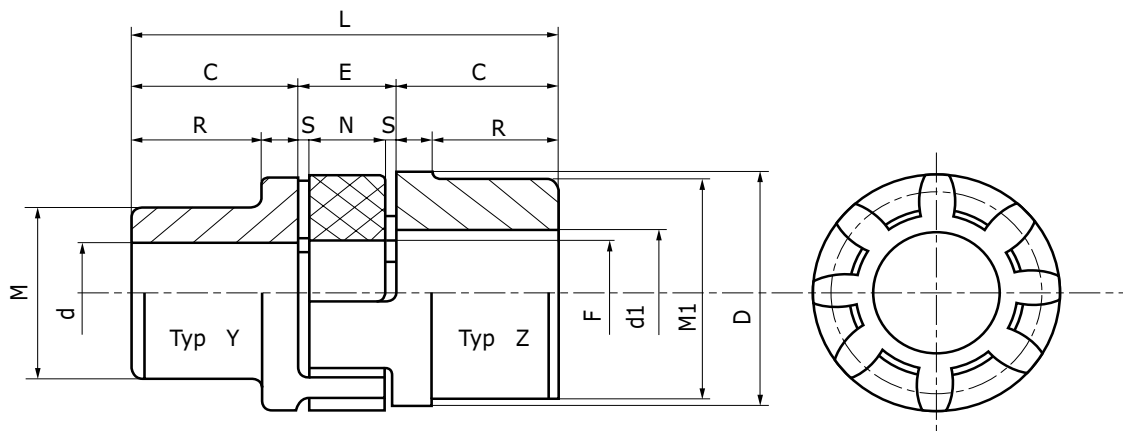

STERNKUPPLUNGEN - Guss EN-GJL-200 UNI EN 1561																
Art. Nr.*	∅ Vorbohrung		d _{max}	d1 _{max}	C	D	E	F	M	M1	N	R	S	L	Max. Geschwindigkeit (tr/min)	Drehmoment nominal (Nm)
	Nabe Y	Nabe Z														
AEP 19Y-19Z**	-	-	19	24	25	40	16	18	30	40	12	19	2	66	14 000	17
AEP 24Y-24Z	-	-	24	32	30	55	18	27	40	55	14	24	2	78	10 600	60
AEP 28Y-28Z	-	-	28	38	35	65	20	30	48	65	15	27,5	2,5	90	8 500	160
AEP 38Y-38Z	-	-	38	45	45	80	24	38	66	78	18	36,5	3	114	7 100	325
AEP 42Y-42Z	-	-	42	55	50	95	26	46	75	94	20	40	3	126	6 000	450
AEP 48Y-48Z	-	-	48	60	56	105	28	51	85	104	21	45	3,5	140	5 600	525
AEP 55Y-55Z	-	-	55	70	65	120	30	60	98	118	22	52	4	160	4 150	625
AEP 65Y-65Z	-	-	65	75	75	135	35	68	115	134	26	61	4,5	185	4 250	640
AEP 75Y-75Z	-	-	75	90	85	160	40	80	135	158	30	69	5	210	3 550	1465
AEP 90Y-90Z	38	38	90	100	100	200	45	100	160	180	34	81	5,5	245	2 800	3600

* Beispiel einer Kupplung mit einer Y-Nabe und einer Z-Nabe
 ** Ausführung in Stahl
 (1) Kupplungsstern aus gehärtetem, rotem, thermoplastischen Elastomer 98 Shore A
 Auf Wunsch fertig gebohrt ∅dH7 und genutet

STERNKUPPLUNGEN - ALUMINIUM															
Art. Nr.*	∅ Vorbohrung		d _{max}	d1 _{max}	C	D	E	F	M	M1	N	R	S	L	Drehmoment nominal (Nm)
	Nabe Y	Nabe Z													
AEP 19Y-19Z / AL	-	10	19	24	25	40	16	18	30	40	12	19	2	66	17
AEP 24Y-24Z / AL	8	14	24	32	30	55	18	27	40	55	14	24	2	78	60
AEP 28Y-28Z / AL	10	16	28	38	35	65	20	30	48	65	15	27,5	2,5	90	160
AEP 38Y-38Z / AL	12	20	38	45	45	80	24	38	66	78	18	36,5	3	114	325

* Beispiel einer Kupplung mit einer Y-Nabe und einer Z-Nabe



STERNKUPPLUNGEN

MATERIAL: Guss
EN-GJL-200 UNI EN 1561

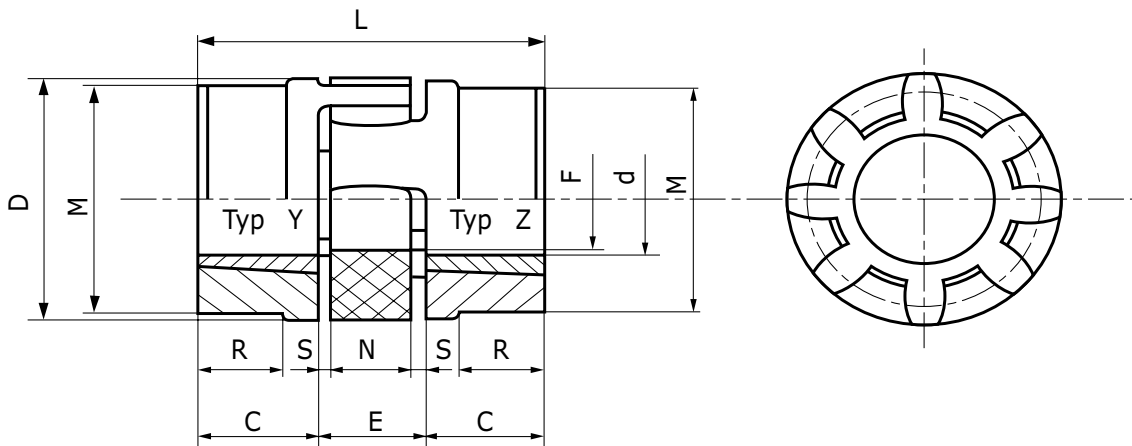
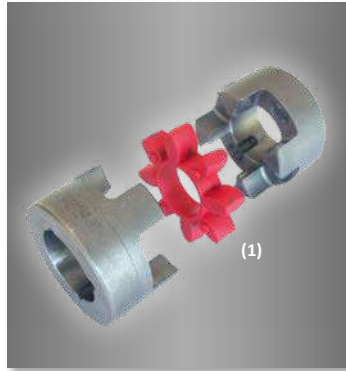

STERNKUPPLUNGEN für Klemmbuchsen - Guss EN-GJL-200 UNI EN 1561													
Art. Nr.*	Nabe	Max. Bohrung		Standardnabe								Nenn-Drehmoment (Nm)	
		d		C	D	E	F	M	N	R	S		L
		Min	Max										
AEP 28Y-28Z MA	1108	9	28	23	65	20	30	65	15	2.5	-	66	160
AEP 38Y-38Z MA	1108	9	28	23	80	24	38	78	18	3	15	70	325
AEP 42Y-42Z MA	1610	14	42	26	95	26	46	94	20	3	16	78	450
AEP 48Y-48Z MA	1615	14	42	39	105	28	51	104	21	3.5	28	106	525
AEP 55Y-55Z MA	2012	14	50	33	120	30	60	118	22	4	20	96	625
AEP 75Y-75Z MA	2517	16	60	52	160	40	80	158	30	5	36	144	1 465

* Beispiel einer Kupplung mit einer Y-Nabe und einer Z-Nabe
(1) Kupplungsstern aus gehärtetem, rotem, thermoplastischen Elastomer 94 Shore A oder gehärtetem, gelbem 92 Shore



DREHELASTISCHE HRC-KUPPLUNGEN FÜR KLEMMBUCHSEN

MATERIAL: Guss
EN-GJL-200 UNI EN 1561

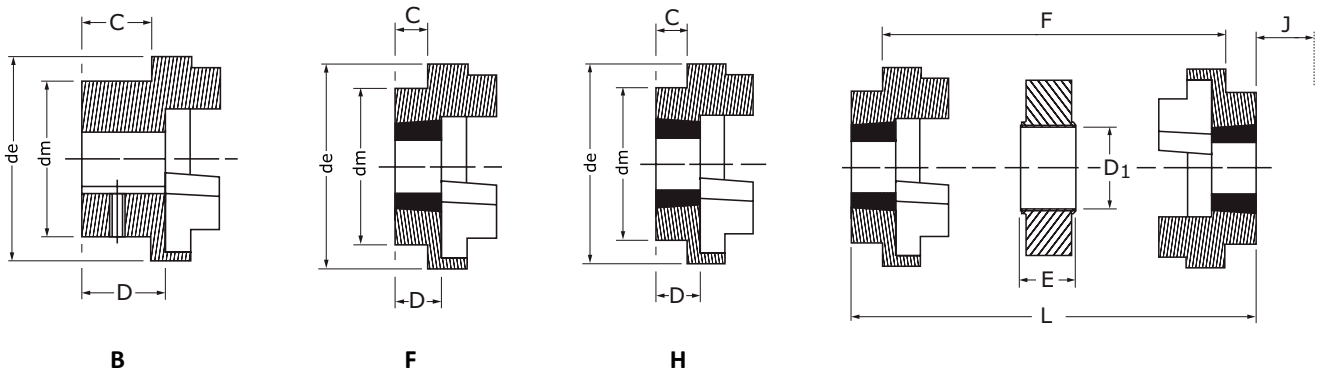
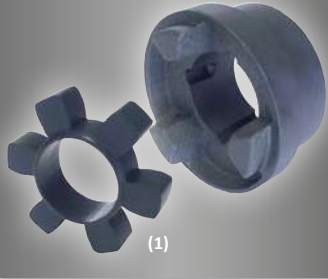

DREHELASTISCHE HRC-KUPPLUNGEN																					
Art. Nr.	Abmessungen					Typ F & H						Typ B					Länge L			Geschwindigkeit Maximum (tr/min)	Drehmoment Nominal (Nm)
	de	dm	D1	F	E	Ø der Bohrung			C	D	J	Ø der Bohrung			laut Kombination						
						Nabe	Min.	Max.				C	D	Vis	Min.	Max.	FF,FH,HH	FB,HB	BB		
HRC070..	69	60	31	25	18	1008	9	25	20	23,5	29	20	23,5	M6	0	32	65	65	65	9100	31,5
HRC090..	85	70	32	30,5	22,5	1108	9	28	19,5	23,5	29	26	30	M6	0	42	69,5	76	82,5	7400	80
HRC110..	112	100	45	45	29	1610	14	42	18,5	26,5	38	37	45	M10	0	55	82	100,5	119	5630	160
HRC130..	130	105	50	53	36	1610	14	42	18	26,5	38	39	47,5	M10	0	60	89	110	131	4850	315
HRC150..	150	115	62	60	40	2012	14	50	23,5	33,5	42	46	56	M10	0	70	107	129,5	152	4200	600
HRC180..	180	125	77	73	49	2517	16	65	34,5	46,5	48	58	70	M10	0	80	142	165,5	189	3500	950
HRC230..	225	155	99	85,5	59,5	3020	25	75	39,5	52,5	55	77	90	M12	48	100	164,5	202	239,5	2800	2000
HRC280..	275	206	119	105,5	74,5	3525	35	90	51	66,5	67	90	105,5	M16	60	115	207,5	246,5	285,5	2300	3150

.. Führen Sie die Kombination genauer an: BB, FF, HH, BF, BH, FH

Die Nabe vom Typ F (Taperbuchse einlaufend an der Innenseite), H (Taperbuchse einlaufend an der Außenseite) & B (vorgebohrt) sind austauschbar.

J: Erforderliches Maß für den Durchgang des Schlüssels zur Montage und Demontage der abnehmbaren Nabe.

(1) Schwarzer Elastomer-Kupplungsstern 90 Shore A.



FLEXIBLE KUPPLUNGEN

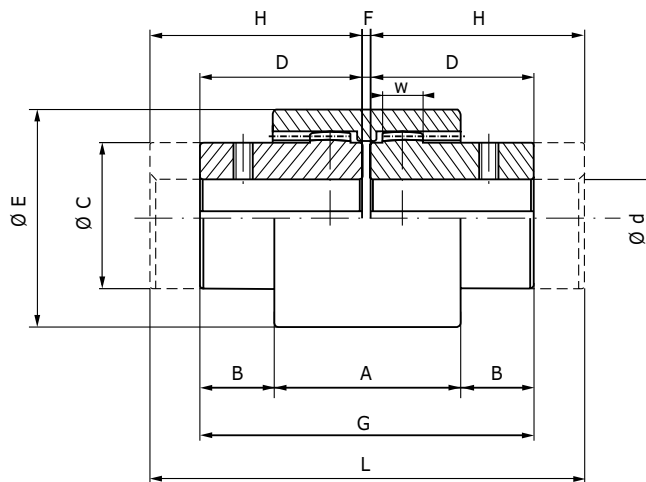

FLEXIBLE KUPPLUNGEN MIT GEWÖLBTER ZAHNUNG, MIT POLYAMID-KRANZ 6.6														Geschwindigkeit Maximum (tr/min)	Drehmoment Nominal (Nm)
Art. Nr.	Ø der Bohrung d		Z	W	A	B	Ø C	D	Ø E	F	G	H	L		
	Nom.	Max.													
GF 14 ..	6	14	20	8	37	6.5	24	23	40	4	50	40	84	14000	10
GF 19 ..	8	19	24	8	37	8.5	30	25	48	4	54	40	84	12000	16
GF 24 ..	10	24	28	8	41	7.5	36	26	52	4	56	50	104	10000	20
GF 28 ..	10	28	34	10	46	19	44	40	66	4	84	55	114	8000	45
GF 32 ..	12	32	40	10	48	18	50	40	76	4	84	55	114	7100	60
GF 38 ..	14	38	44	12	48	18	58	40	83	4	84	60	124	6300	80
GF 42 ..	20	42	50	14	50	19	65	42	92	4	88	60	124	6000	100
GF 48 ..	20	48	50	14	50	27	67	50	95	4	104	60	124	5600	140
GF 55 ..	25	55	45	16	58	25	82	52	114	4	108	65	134	4800	285
GF 65 ..	25	65	42	20	68	23	95	55	132	4	114	70	144	4000	380

.. Kodifizierungsbeispiel:

Einziges Element:

GF-..N = Standardnabe

GF-..L = Lange Nabe

GF-..M = Polyamidelement 6.6

Komplette Kupplung:

GF .. NN = mit 2 Standardnaben

GF .. NL = mit 1 Standardnabe + 1 Langnabe

GF .. LL = mit 2 Langnaben

Technische Daten:

- Einfache Montage und Demontage
- Einsatztemperatur von -20°C bis +120°C
- Geräuscharmer Lauf
- Winkelversatz, axial ($\pm 1\text{mm}$) und Radius ($\pm 2^\circ$) gemäß der konvexen Form der Zahnung
- Wartungsfreiheit

Auf Anfrage Bearbeitung der Bohrung H7 und Passfedernut JS9

- Material: Stahl C43 UNI 7847

sedis 

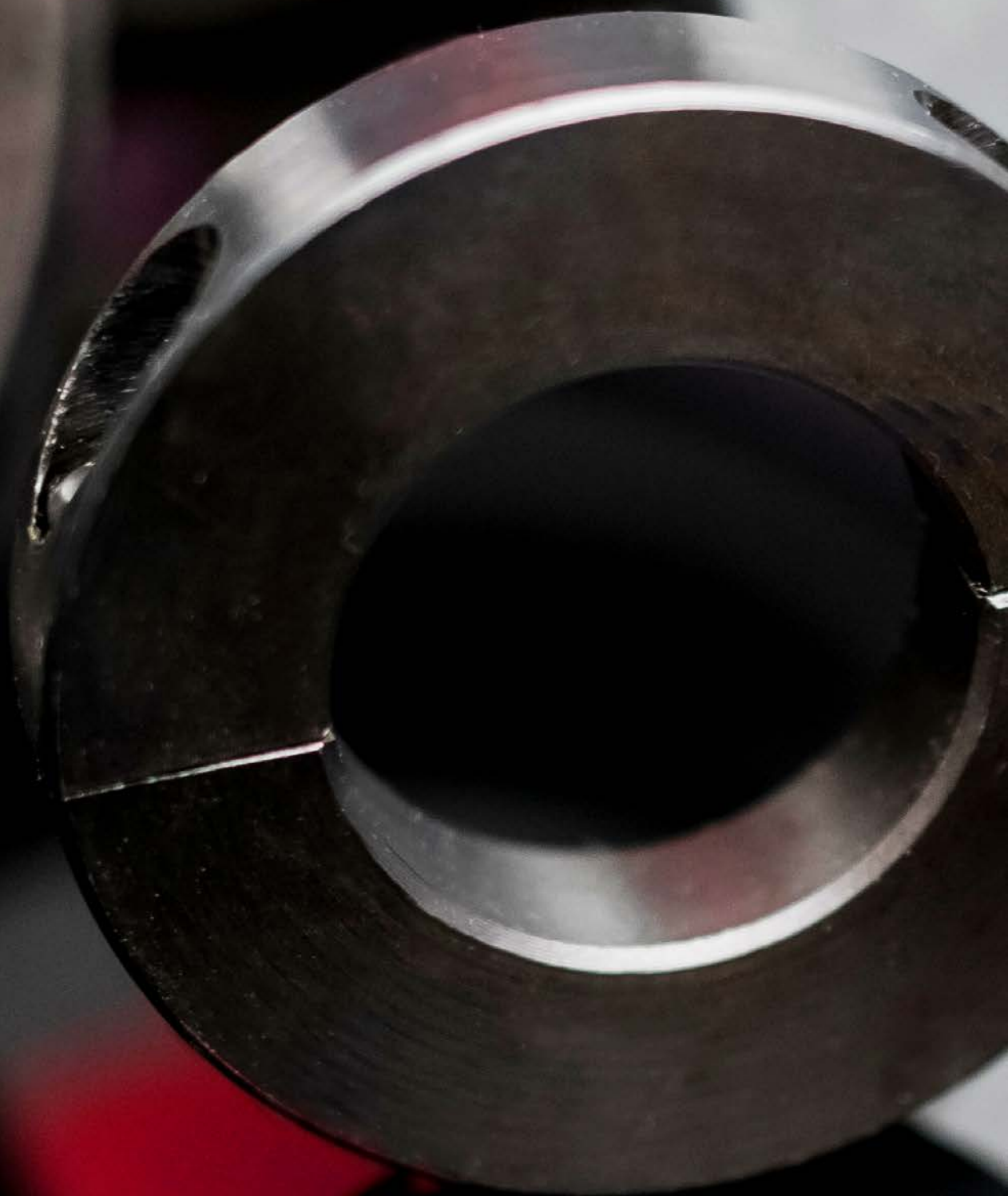



ZUBEHÖR



ANSCHWEISSNABEN FÜR KLEMMBUCHSEN

MATERIAL: Stahl

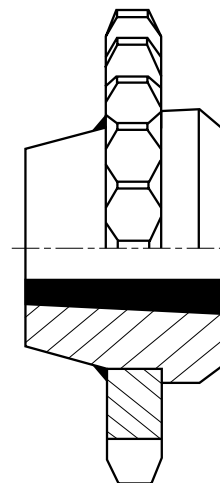
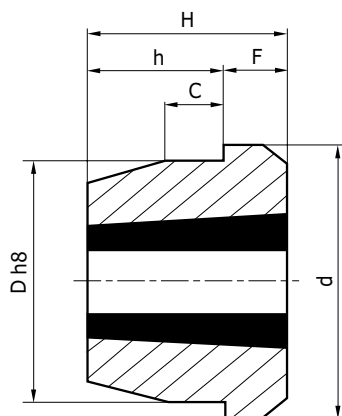

Art. Nr.	Buchse	d	H	C	F	h	D	Kg
MSB1210	1210	73	25	10	9	16	60	0,31
MSB1215	1215	73	38	11	16	22	60	0,50
MSB1610	1610	83	25	10	9	16	70	0,37
MSB1615	1615	83	38	11	16	22	70	0,60
MSB2012	2012	96	32	12	10	22	90	0,72
MSB2517	2517	127	45	13	19	26	110	1,80
MSB3020	3020	152	51	18	24	27	130	2,59
MSB3030	3030	152	76	19	25	51	130	3,55
MSB3525	3525	184	65	25	25	40	155	7,30
MSB3535	3535	184	89	25	32	57	155	6,40
MSB4040	4040	225	102	35	32	70	195	13,22
MSB4545	4545	254	114	40	38	76	220	19,30
MSB5050	5050	276	127	40	38	89	242	24,52



ANSCHRAUBNABEN FÜR KLEMMBUCHSEN

MATERIAL: Guss

Nabe (glatte Bohrungen) für Klemmbuchsen

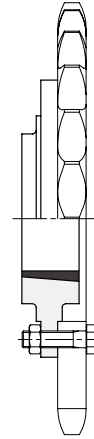
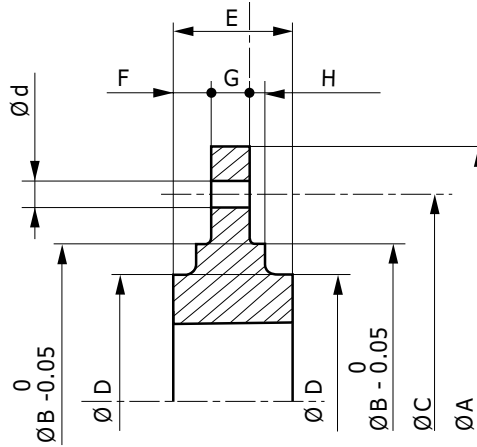

Art. Nr.	Buchse	Ø A	Ø B	Ø C	Ø D	E	F	G	H	Anzahl der Bohrungen	Ø d
MBB 120 MA	1210	120	80	100	70	25	9	7,5	2,5	6	7,5
MBB 130 MA	1610	130	90	110	80	25	9	7,5	2,5	6	7,5
MBB 145 MA	2012	145	115	125	95	32	12	9,5	2,5	6	9,5
MBB 185 MA	2517	185	130	155	115	45	19	12,5	2,5	6	11,5
MBB 220 MA	3020	220	165	190	145	51	19	12,5	2,5	6	13,5
MBB 180 MA	1210	180	90	135	75	25	9,25	6,5	2,5	6	7,5
MBB 200 MA	1615	200	110	150	85	38	15,3	7,5	2,5	6	7,5
MBB 270 MA	2012	270	140	190	110	32	11,8	8,5	2,5	6	9,5
MBB 340 MA	2517	340	170	240	125	45	17,8	9,5	2,5	8	11,5
MBB 430 MA	3020	430	220	300	160	51	18,8	13,5	2,5	8	13,5
MBB 485 MA*	3020	485	250	340	160	51	18,8	13,5	2,5	8	13,5

* Stahl

MOTORSPANNSCHIENEN

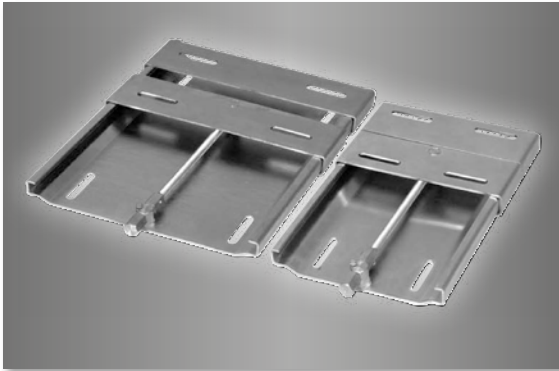

Hergestellt aus verzinktem Stahl. Die Behandlung wird nach dem Biegen durchgeführt, um optimalen Korrosionsschutz zu erreichen.

Leichter und rascher Einbau. Diese Schienen ermöglichen das Austauschen eines Riemens ohne Demontage des Motors.

Einfaches Einstellen der Riemen­spannung mit Hilfe der Stellschraube (Verwendung eines Standardschlüssels).

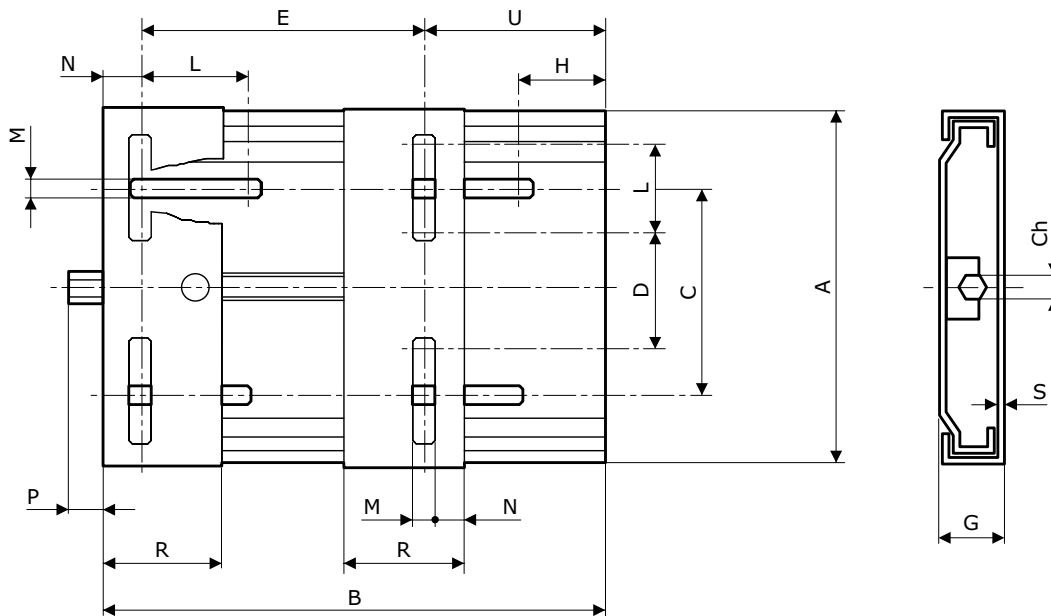

Art. Nr.	A	B	C	D	E	G	H	L	M	N	P	R	S	U	Ch	Abmessungen des Motors
GM00210	195	210	98	43	100	34	25	50	10,5	20	38	70	3	90	19	63 / 80
GM00270	195	270	98	43	100	33	25	50	10,5	20	38	70	3	150	19	63 / 112
GM00307	213	307	108	65	100	35	30	50	10,5	20	42	70	3	175	19	90 / 112
GM00340	280	340	165	90	135	40	30	62	12,5	27	26	95	4	180	22	90 / 132
GM00430	285	430	165	90	132	40	29	62	12,5	27	30	95	4	271	22	90 / 160
GM00490	410	490	284	193	114	40	30	60	15,0	40	24	95	4	336	22	160 / 180



KLEMMRINGE GEMÄSS DIN 705

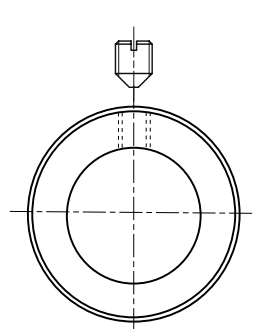
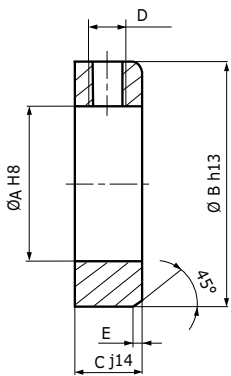

Typ 1

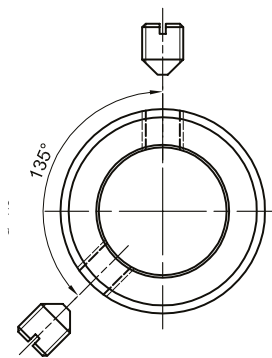

Typ 2

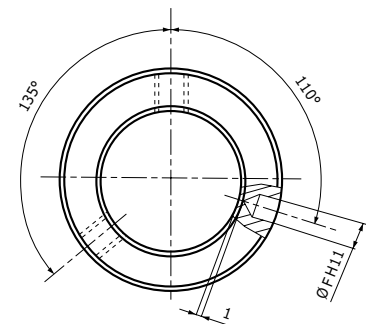

Typ 3

Art. Nr.	A	B	C	D	E	Typ	Kg
BAG 3 ..	3	7	5	M2	0,5	1	0,12
BAG 4 ..	4	8	5	M2,5	0,5	1	0,15
BAG 5 ..	5	10	6	M3	0,6	1	0,28
BAG 6 ..	6	12	8	M4	0,8	3	0,54
BAG 7 ..	7	12	8	M4	0,8	1	0,48
BAG 8 ..	8	16	8	M4	0,8	3	0,94
BAG 9 ..	9	18	10	M5	1	1	1,51
BAG 10 ..	10	20	10	M5	1	3	1,85
BAG 12 ..	12	22	12	M6	1,2	3	2,52
BAG 14 ..	14	25	12	M6	1,2	3	3,17
BAG 15 ..	15	25	12	M6	1,2	3	2,98
BAG 16 ..	16	28	12	M6	1,2	3	3,84
BAG 17 ..	17	28	12	M6	1,2	3	4,00
BAG 18 ..	18	32	14	M6	1,4	3	6,00
BAG 20 ..	20	32	14	M6	1,4	3	5,30
BAG 22 ..	22	36	14	M6	1,4	1	6,90
BAG 25 ..	25	40	16	M8	1,6	3	9,56
BAG 30 ..	30	45	16	M8	1,6	3	11,10
BAG 35 ..	35	56	16	M8	1,6	3	18,70
BAG 40 ..	40	63	18	M10	1,8	3	26,10
BAG 45 ..	45	70	18	M10	1,8	3	31,70
BAG 50 ..	50	80	18	M10	1,8	3	42,90
BAG 55 ..	55	80	18	M10	1,8	1	37,30
BAG 60 ..	60	90	20	M10	2	3	55,20
BAG 65 ..	65	100	20	M10	2	1	70,80
BAG 70 ..	70	100	20	M10	2	3	62,60
BAG 80 ..	80	110	22	M12	2,2	2	76,80
BAG 90 ..	90	125	22	M12	2,2	2	101,00
BAG 100 ..	100	140	25	M12	2,5	2	147,00

... PH hinzufügen für Phosphorisierung / ZN für Verzinkung / IN für Edelstahl



KLEMMRINGE MIT SCHULTER

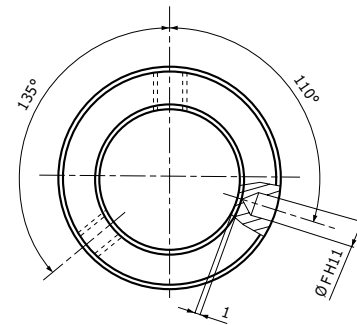
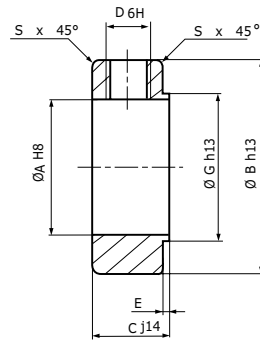

Art. Nr.	A	B	C	D	E	F	G	S	Kg
BAG/E 6 ..	6	12	8	M4	0,6	1,5	8	0,3	0,0054
BAG/E 8 ..	8	16	8	M4	0,8	2	10	0,3	0,0094
BAG/E 10 ..	10	20	10	M5	0,8	3	13	0,3	0,0185
BAG/E 12 ..	12	22	12	M5	0,8	4	15	0,5	0,0252
BAG/E 15 ..	15	25	12	M6	1	4	18	0,6	0,0298
BAG/E 17 ..	17	28	12	M6	1	4	20	0,6	0,04
BAG/E 20 ..	20	32	14	M6	1	5	24	0,8	0,053
BAG/E 25 ..	25	40	16	M6	1	6	29	0,8	0,956
BAG/E 30 ..	30	45	16	M8	1,2	6	34	1	0,111
BAG/E 35 ..	35	56	16	M8	1,2	8	39	1	0,187
BAG/E 40 ..	40	63	18	M10	1,2	8	44	1	0,261

... PH hinzufügen für Phosphorisierung / ZN für Verzinkung

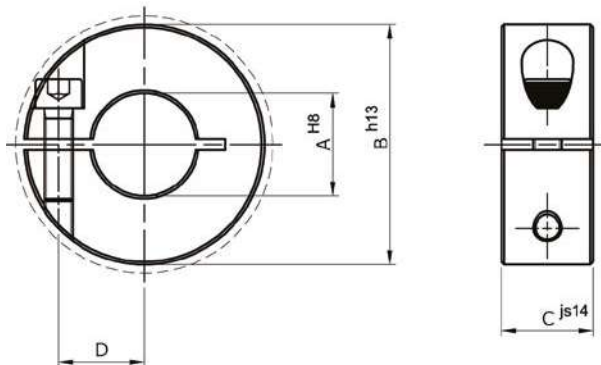
KLEMMRINGE EINTEILIG

Art. Nr.	A	B	C	D	Vis	Kg
BAG 4 / 1 ..	4	16	9	5,5	M3 x 8	0,011
BAG 5 / 1 ..	5	16	9	5,5	M3 x 8	0,010
BAG 6 / 1 ..	6	16	9	5,5	M3 x 8	0,010
BAG 8 / 1 ..	8	18	9	6,5	M3 x 8	0,012
BAG 10 / 1 ..	10	24	9	8,5	M3 x 8	0,022
BAG 12 / 1 ..	12	28	11	10,0	M4 x 12	0,038
BAG 14 / 1 ..	14	30	11	11,0	M4 x 12	0,042
BAG 15 / 1 ..	15	34	13	12,5	M5 x 14	0,065
BAG 16 / 1 ..	16	34	13	12,5	M5 x 14	0,063
BAG 18 / 1 ..	18	36	13	13,5	M5 x 14	0,069
BAG 19 / 1 ..	19	40	15	14,7	M6 x 16	0,100
BAG 20 / 1 ..	20	40	15	14,7	M6 x 16	0,097
BAG 22 / 1 ..	22	42	15	16,0	M6 x 16	0,103
BAG 23 / 1 ..	23	45	15	17,5	M6 x 16	0,122
BAG 24 / 1 ..	24	45	15	17,5	M6 x 16	0,117
BAG 25 / 1 ..	25	45	15	17,5	M6 x 16	0,114
BAG 26 / 1 ..	26	48	15	19,0	M6 x 18	0,133
BAG 28 / 1 ..	28	48	15	19,0	M6 x 18	0,123
BAG 30 / 1 ..	30	54	15	21,5	M6 x 18	0,163
BAG 32 / 1 ..	32	54	15	21,5	M6 x 18	0,156
BAG 35 / 1 ..	35	57	15	23,2	M6 x 18	0,171
BAG 36 / 1 ..	36	57	15	23,2	M6 x 18	0,163
BAG 38 / 1 ..	38	60	15	25,0	M6 x 18	0,178
BAG 40 / 1 ..	40	60	15	25,0	M6 x 18	0,163
BAG 45 / 1 ..	45	73	19	29,5	M8 x 25	0,344
BAG 48 / 1 ..	48	78	19	32,0	M8 x 25	0,392
BAG 50 / 1 ..	50	78	19	32,0	M8 x 25	0,370
BAG 55 / 1 ..	55	82	19	34,2	M8 x 25	0,380
BAG 60 / 1 ..	60	88	19	37,0	M8 x 25	0,425
BAG 70 / 1 ..	70	98	19	42,0	M8 x 25	0,480
BAG 80 / 1 ..	80	108	19	47,0	M8 x 25	0,535

... PH hinzufügen für Phosphorisierung / ZN für Verzinkung / IN für Edelstahl

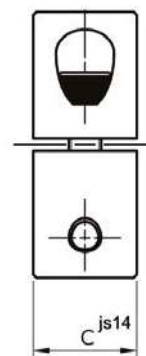
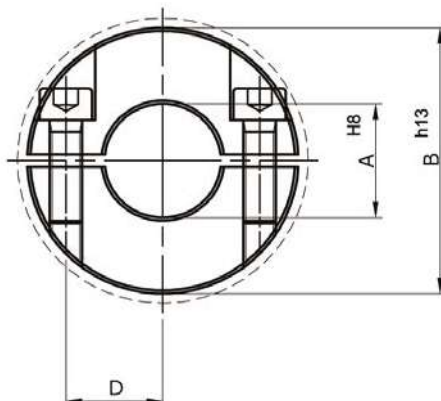
KLEMMRINGE ZWEITEILIG



Art. Nr.	A	B	C	D	Vis	Kg
BAG 4 / 2 ..	4	16	9	5,5	M3 x 8	0,011
BAG 5 / 2 ..	5	16	9	5,5	M3 x 8	0,011
BAG 6 / 2 ..	6	16	9	5,5	M3 x 8	0,010
BAG 8 / 2 .. C	8	25	10		M4 x 15	0,012
BAG 10 / 2 .. C	10	32	10		M4 x 15	0,024
BAG 12 / 2 .. C	12	32	10		M4 x 15	0,039
BAG 14 / 2 ..	14	30	11	11,0	M4 x 12	0,043
BAG 15 / 2 .. C	15	40	12		M5 x 20	0,068
BAG 16 / 2 ..	16	34	13		M5 x 14	0,065
BAG 18 / 2 .. C	18	45	12		M5 x 20	0,071
BAG 19 / 2 ..	19	40	15	14,7	M6 x 16	0,104
BAG 20 / 2 .. C	20	45	12		M5 x 20	0,101
BAG 22 / 2 ..	22	42	15	16,0	M6 x 16	0,107
BAG 23 / 2 ..	23	45	15	17,5	M6 x 16	0,127
BAG 24 / 2 .. C	24	50	12		M5 x 20	0,122
BAG 25 / 2 .. C	25	50	12		M5 x 20	0,120
BAG 26 / 2 ..	26	48	15	19,0	M6 x 18	0,139
BAG 28 / 2 .. C	28	56	12		M5 x 20	0,128
BAG 30 / 2 .. C	30	56	12		M5 x 20	0,171
BAG 32 / 2 .. C	32	56	12		M5 x 20	0,161
BAG 35 / 2 .. C	35	63	12		M5 x 20	0,172
BAG 36 / 2 ..	36	57	15	23,2	M6 x 18	0,169
BAG 38 / 2 .. C	38	63	12		M5 x 20	0,183
BAG 40 / 2 .. C	40	70	14		M6 x 20	0,172
BAG 45 / 2 .. C	45	80	14		M6 x 20	0,360
BAG 48 / 2 ..	48	78	19	32,0	M8 x 25	0,414
BAG 50 / 2 .. C	50	80	14		M6 x 20	0,386
BAG 55 / 2 ..	55	82	19	34,2	M8 x 25	0,395
BAG 60 / 2 .. C	60	100	16		M8 x 20	0,440
BAG 70 / 2 .. C	70	110	20		M10 x 25	0,495
BAG 80 / 2 ..	80	125	20		M10 x 25	0,550

... PH hinzufügen für Phosphorisierung / ZN für Verzinkung / IN für Edelstahl
 „C“ nur mit PH

***WAHRHAFTES STÄRKE
IN EINER WELT IM
STETIGEN WECHSEL***

SEDIS - HAUPTVERWALTUNG

6 rue Nicolat Siret
CS 90104, 10003 TROYES Cedex
France

 +33 (0) 3 25 76 29 50

 <https://sedis.com/contact>

 www.sedis.com

 <https://www.linkedin.com/company/sedis>

SEDIS - ZENTRALLAGER

9 rue de la Douane
10600 LA CHAPELLE SAINT LUC
France

 +33 (0) 3 10 64 17 80

SEDIS - PRODUKTION VERRIÈRES

6 rue de Verjoux
25300 VERRIERES-DE-JOUX
France

 +33 (0) 3 81 38 40 60

SEDIS - PRODUKTION TROYES

35 rue des Bas Trévois
CS 90104, 10003 TROYES Cedex
France

 +33 (0) 3 25 76 29 50

SEDIS COMPANY LTD

248 Mackadown Lane, Kitts Green
BIRMINGHAM, B33 0LE
UK

 +44 (0) 870 160 7840

 sales@sedis.co.uk

SEDIS ITALIA

Via Pietro Mascagni 42
20030 SENAGO (MI)
ITALIA

 +39 (0) 2 47 76 11 97

 +39 (0) 2 38 23 67 76

 aconan@sedis.com

SEDIS GMBH

Huttropstr. 60
D-45138 Essen
DEUTSCHLAND

 +49 (0) 173 211 33 54

 spidansat@sedis.com