

KLEMMBUCHSEN

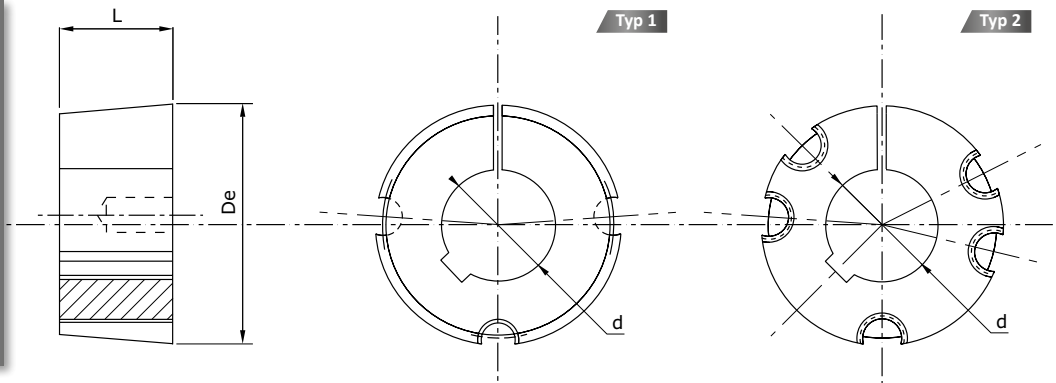

Art. Nr.	Bohrung in mm (d)	De	L	TEILUNG	Typ	Über- moment (Nm)	Anzugs- moment (Nm)	Kg
MA1008A..	9-10-11-12-14-16-18-19-20-22-24-25	35,0	22,3	1/4" x 1/2"	1	136	5,6	0,16
MA1108A..	28,20 9-10-11-12-14-16-18-19-20-22-24-25-28Δ	38,0	22,3	1/4" x 1/2"	1	147	5,6	0,16
MA1210A..	30,25 11-12-14-16-18-19-20-22-24-25-28-30-32	47,5	25,4	3/8" x 5/8"	1	407	19,6	0,32
MA1215A..	30,40 14-19-20-24-25-28-30-32	47,5	38,1	3/8" x 5/8"	1	407	19,6	0,50
MA1610A..	40,25 14-16-18-19-20-22-24-25-28-30-32-35-38-40Δ-42Δ	57,0	25,4	3/8" x 5/8"	1	486	19,6	0,50
MA1615A..	40,40 14-16-18-19-20-22-24-25-28-30-32-35-38-40Δ-42Δ	57,0	38,1	3/8" x 5/8"	1	486	19,6	0,60
MA2012A..	50,30 14-16-18-19-20-22-24-25-28-30-32-35-38-40-42-45-48-50Δ	70,0	31,8	7/16" x 7/8"	1	808	30,4	0,75
MA2517A..	65,45 16-18-19-20-22-24-25-28-30-32-35-38-40-42-45-48-50-55-60	85,5	44,5	1/2" x 1"	1	1310	48,0	1,06
MA3020A..	75,50 25-28-30-32-35-38-40-42-45-48-50-55-60-65-70-75	108,0	50,8	5/8" x 1" 1/4	1	2710	90,0	2,50
MA3030A..	75,75 35-38-40-42-45-48-50-55-60-65-70-75-80	108,0	76,2	5/8" x 1" 1/2	1	2710	90,0	3,75
MA3525A..	35-38-40-42-45-48-50-55-60-65-70-75-80	127,0	64,9	1/2" x 1" 1/2	2	5060	113,0	4,20
MA3535A..	90,90 35-38-40-42-45-48-50-55-60-65-70-75-80-85-90Δ	127,0	88,9	1/2" x 1" 1/2	2	5060	113,0	5,13
MA4030A..	40-42-45-48-50-55-60-65-70-75-80-85-90-100Δ	146,0	76,2	5/8" x 1" 1/2	2	8740	169,0	6,75
MA4040A..	100,100 40-42-45-48-50-55-60-65-70-75-80-85-90-100Δ	146,0	101,6	5/8" x 1" 3/4	2	8740	169,0	7,68
MA4545A..	115,115 55-60-65-70-75-80-85-90-100Δ-115Δ-120Δ	162,0	115,0	3/4" x 2"	2	12400	192,0	10,56
MA5050A..	125,125 70-75-80-85-90-100-105-110-115-120-125	177,6	127,0	7/8" x 2" 1/4	2	12400	272,0	15,17

.. Durchmesser der Bohrung
 Δ Unten liegende Passfeder

Abmessungen der Standard-Passfedernuten

d	a	JS9	F
10 bis 12	4		D + 1,8
" 12 " 17	5	± 0,015	D + 2,3
" 17 " 22	6		D + 2,8
" 22 " 30	8	± 0,018	D + 3,3
" 30 " 38	10		D + 3,3
" 38 " 44	12		D + 3,3
" 44 " 50	14	± 0,021	D + 3,8
" 50 " 58	16		D + 4,3
" 58 " 65	18		D + 4,4
" 65 " 75	20		D + 4,9
" 75 " 85	22	± 0,026	D + 5,4
" 85 " 95	25		D + 5,4
" 95 " 110	28		D + 6,4
" 110 " 130	32	± 0,031	D + 7,4

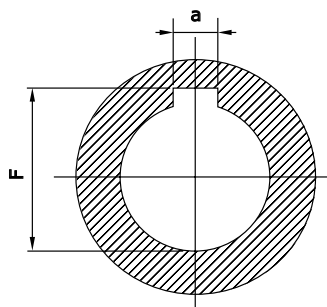

Abmessungen der Standard-Passfedernuten Δ

d	a	F
28	8	D + 1,3
35	10	D + 1,3
40 / 42	12	D + 1,3
50	14	D + 2,8
65	18	D + 2,8
90	25	D + 3,4
100	28	D + 5,4