

CADENAS CON ALETAS A 90° TIPO "K" - conformes a la norma ISO 606

APLICACIONES

Transportadores y maquinas especiales, montaje en transportadores usando 2 o varias cadenas en paralelo.

ENVÍO POSIBLE DENTRO 48 HORAS

Para las referencias indicadas

50M MÁXIMO (consúltenos)

EMPAREJAMIENTO POSIBLE PARA MÁS PRECISIÓN.

K1C



K3L



ALETAS K1C

montaje posible en todos los pasos a uno o ambos lados salvo 17T.
(cada 2 pasos como mínimo sobre eslabones exteriores, a uno o a ambos lados).

Dimensiones en mm

Referencia	ISO 606	SEDIS	Paso P	GAMA SEDIS					CADENA VERTE	d1	b1	b4	B	C	D	E	F	G	H
				ALPHA Premium	ALPHA Premium INOX	DELTA® HR	DELTA® Titanium 2												
Aletas K1C - Eslabón EXTERIOR																			
06B-1	3N	9,525	x		x	x		(1)	6,35	5,77	12,50	3,10	19,85	29,05	6,55	8,30		1	
08B-1	7N	12,7	**		x	x		(1)	8,51	7,75	16,60	4,30	25,40	37,95	9,20	10,70		1,3	
10B-1	11N	15,875	x		x	x		(1)	10,16	9,65	19,00	5,30	31,75	46,65	10,60	13,80		1,6	
12B-1	13N	19,05	**		x	x		(1)	12,07	11,68	22,30	7,12	38,10	61,00	13,80	16,50		1,8	
16B-1	15T	25,4	x	x	x	x		(1)	15,88	17,02	35,10	8,40	50,80	74,00	16,15	20,76		3	
20B-1	17T	31,75	x		x	x			19,05	19,56	40,50	8,40	63,50	96,00	20,10	25,76		3,5	
(*)	18T	38,1	x		x	x			25,40	25,40	53,10	11,00	88,00	129,0	25,00	38,00		5	
Aletas K1C - Eslabón INTERIOR																			
08B-1	7N	12,7	x		x	x			8,51	7,75	16,60	4,30	25,40	35,55	9,20	10,70		1,6	
10B-1	11N	15,875	x		x	x			10,16	9,65	19,00	5,30	31,75	42,65	10,60	13,80		1,6	
12B-1	13N	19,05	x		x	x			12,07	11,68	22,30	7,12	38,10	57,00	13,80	16,50		1,8	
16B-1	15T	25,4	x		x	x			15,88	17,02	35,10	8,40	50,80	74,00	16,15	20,76		3,9	
20B-1	17T	31,75	x		x	x			19,05	19,56	40,50	8,40	63,50	96,0	20,10	25,76		4,5	

**** ALETAS K1C CADA 2 PASOS DE UN LADO EN EL ESLABÓN EXTERIOR DISPONIBLES EN STOCK**

K1C: Aleta corta con 1 taladro

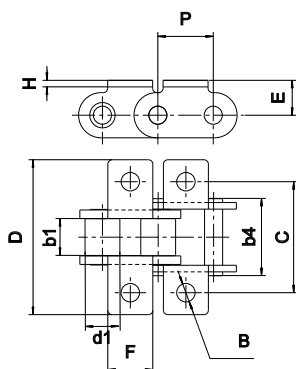

ALETAS K1L - K2L - K3L

montaje cada dos pasos mínimo, a uno o a ambos lados

Aletas K1L - Eslabón EXTERIOR																		
06B-1	3N	9,525	x		x	x			6,35	5,77	12,50	3,10	19,85	29,05	6,55	17,70		1,00
08B-1	7N	12,7	x		x	x		(1)	8,51	7,75	16,60	4,30	25,40	37,95	9,20	24,50		1,30
10B-1	11N	15,875	x		x	x		(1)	10,16	9,65	19,00	5,30	31,75	46,65	10,60	29,50		1,60
12B-1	13N	19,05	x		x	x		(1)	12,07	11,68	22,30		Utilizar K3L					
16B-1	15T	25,4	x	x	x	x		(1)	15,88	17,02	35,10	8,40	50,80	74,00	16,15	47,20		3,00
Aletas K1L - Eslabón INTERIOR																		
16B-1	15T	25,4	x		x	x		(1)	15,88	17,02	35,10	8,40	50,80	74,00	16,15	47,20		3,90
Aletas K2L - Eslabón EXTERIOR																		
06B-1	3N	9,525	x		x	x			6,35	5,77	12,50	3,10	19,85	29,05	6,55	17,70		1,00
08B-1	7N	12,7	x		x	x		(1)	8,51	7,75	16,60	4,80	25,40	37,95	9,20	24,50	12,70	1,30
10B-1	11N	15,875	x		x	x		(1)	10,16	9,65	19,00	5,30	31,75	46,65	10,60	29,50	15,88	1,60
12B-1	13N	19,05	x		x	x		(1)	12,07	11,68	22,30		Utilizar K3L					
16B-1	15T	25,4	x	x	x	x		(1)	15,88	17,02	35,10	8,40	50,80	74,00	16,15	47,20	25,40	3,00
(*)	17T	31,75	x		x	x			19,05	19,56	40,50	10,40	69,00	100,00	21,00	57,50	31,70	3,50
(*)	18T	38,1	x		x	x			25,40	25,40	53,10	12,40	88,00	126,00	28,00	72,00	38,10	5,00
28B-1	20T	44,45	x		x	x			27,94	30,99	65,10	13,50	88,90	125,00	28,90	79,60	45,00	6,35
(*)	80-1	25,4	x		x	x			15,88	15,87	33,05	8,40	47,90	71,00	16,15	47,20	25,40	3,00
Aletas K2L - Eslabón INTERIOR																		
08B-1	7N	12,7	x		x	x			8,51	7,75	16,60	4,80	25,40	35,55	9,20	24,50	12,70	1,30
10B-1	11N	15,875	x		x	x			10,16	9,65	19,00	5,30	31,75	42,65	10,60	29,50	15,88	1,60
16B-1	15T	25,4	x		x	x		(1)	15,88	17,02	35,10	8,40	50,80	74,00	16,15	47,20	25,40	3,90
(*)	17T	31,75	x		x	x			19,05	19,56	40,50	10,40	69	100,00	21,00	57,50	31,7	3,50
Aletas K3L - Eslabón EXTERIOR																		
12B-1	13N	19,05	x	x	x	x		(1)	12,07	11,68	22,30	6,40	38,10	61,00	13,80	35,10	19,05	1,80
16B-1	15T	25,4	x	x	x	x		(1)	15,88	17,02	35,10	8,40	50,80	74,00	16,15	47,20	25,40	3,00
(*)	17T	31,75	x		x	x			19,05	19,56	40,5	8,4	63,5	94	20,2	58,2	31,75	3,5
Aletas K3L - Eslabón INTERIOR																		
16B-1	15T	25,4	x		x	x		(1)	15,88	17,02	35,10	8,40	50,80	74,00	16,15	47,20	25,40	3,90

(*) Cuidado, las cotas de estas aletas no están estandarizadas

CADENAS PASO DOBLE - norma ISO 1275

Aletas K1, K2 - Eslabón EXTERIOR																		
210A	2050	31,75	x		x	x		(1)	10,16	9,65	20,45	5,30	31,60	50,60	12,00	28,00	15,90	2,00
Aletas K5 - Eslabón EXTERIOR																		
212A	2060	38,1	x		x	x		(1)	11,91	12,65	25,40	6,50	38,60	57,50	12,00	55,50	38,10	2,35

(1): Referencias en versión Lub Free. En versión Delta®VERTE, consúltenos

Ejecución posible en cadenas dobles o triples



CADENAS ESPECIALES CON ALETAS "B"

Aletas que no cumplen con la norma ISO 606, montadas en una cadena que cumple con la norma ISO 606

APLICACIONES

Transportadores, montaje en transportadores usando generalmente 2 cadenas en paralelo.

EMPAREJAMIENTO POSIBLE PARA MÁS PRECISIÓN.

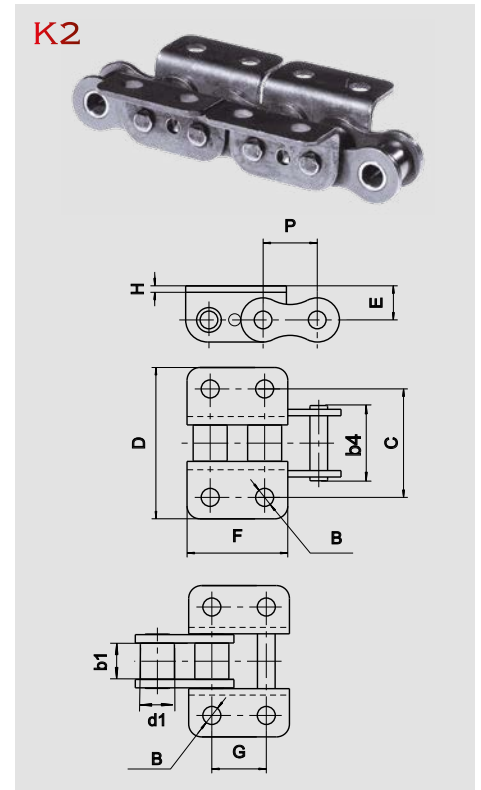
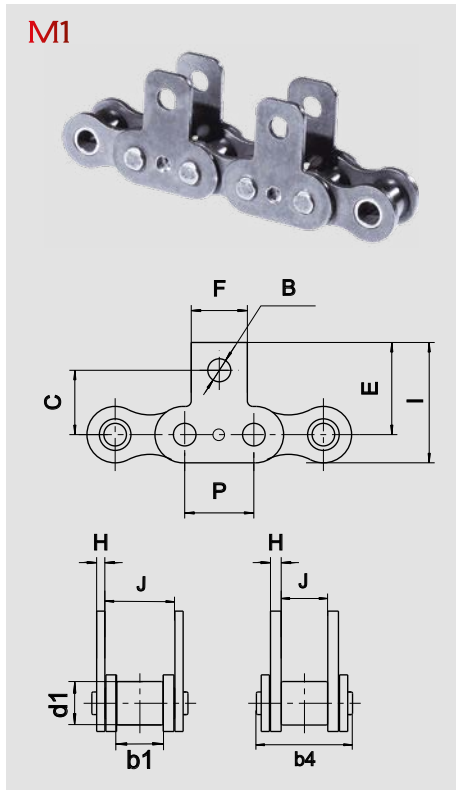
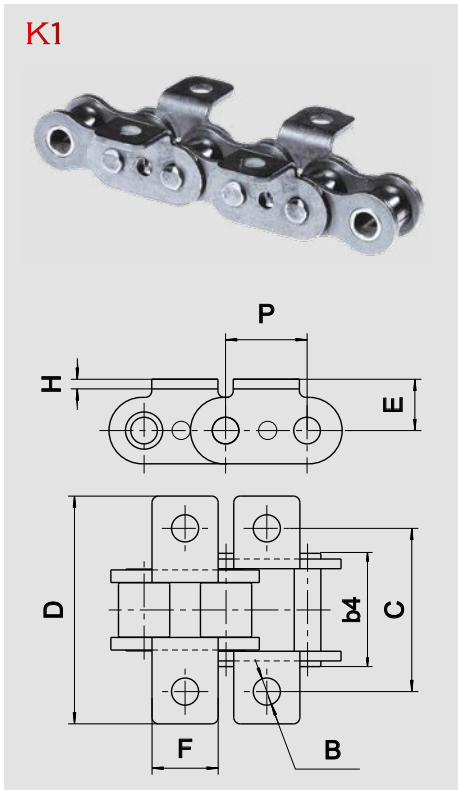

Dimensiones en mm

Referencia	ISO 606	SEDIS	Paso P	GAMA SEDIS						d1	b1	b4	B	C	D	E	F	G	H	I	J
				ALPHA Premium	ALPHA Premium INOX	DELTA® HR	DELTA Titanium 2	Cadenas VERTE													
				max.	min.	max.	min.	med.	max.												
Aletas K1 - Eslabón EXTERIOR																					
08B-1	7N	12,7	x	x	x	x	(1)	8,51	7,75	16,6	4,30	23,80	36,80	9,20	10,70			1,30			
10B-1	11N	15,875	x	x	x	x	(1)	10,16	9,65	19,0	5,30	31,75	45,00	10,60	13,80			1,60			
Aletas K1 - Eslabón INTERIOR																					
08B-1	7N	12,7	x		x	x		8,51	7,75	16,6	4,30	23,80	32,90	9,20	10,70			1,60			
10B-1	11N	15,875	x		x	x		10,16	9,65	19,0	5,30	31,75	41,00	10,60	13,80			1,60			
Aletas M1 - Eslabón EXTERIOR																					
08B-1	7N	12,7	x	x	x	x	(1)	8,51	7,75	16,6	4,30	12,70		19,00	10,70			1,30	25,10	11,45	
10B-1	11N	15,875	x	x	x	x	(1)	10,16	9,65	19,0	5,30	15,90		23,00	13,80			1,60	30,05	13,30	
12B-1	13N	19,05	x		x	x	(1)	12,07	11,68	22,3	7,12	22,20		32,45	16,50			1,80	40,75	15,75	
Aletas M1 - Eslabón INTERIOR																					
08B-1	7N	12,7	x		x	x		8,51	7,75	16,6	4,30	12,70		19,00	10,70			1,60	25,10	7,75	
10B-1	11N	15,875	x		x	x		10,16	9,65	19,0	5,30	15,90		23,00	13,80			1,60	30,05	9,65	
12B-1	13N	19,05	x		x	x		12,07	11,68	22,3	7,12	22,20		32,45	16,50			1,80	40,75	11,68	
Aletas K2 - Eslabón EXTERIOR																					
12B-1	13N	19,05	x		x	x	(1)	12,07	11,68	22,3	5,52	34,90	52,00	11,70	35,10	19,05		1,80			
Aletas K2 - Eslabón INTERIOR																					
12B-1	13N	19,05	x		x	x		12,07	11,68	22,3	5,52	34,90	48,50	11,70	35,10	19,05		1,80			
Aletas M2 - Eslabón EXTERIOR																					
12B-1	13N	19,05	x		x	x	(1)	12,07	11,68	22,3	5,6	17,65	35,1	26,15	34,45	19,05		1,80			

(1): Referencias en versión Lub Free. En versión Delta®VERTE, consúltenos

Para enterarse de las resistencias a la tracción de las cadenas hay que referirse a las tablas de las página 18 y 20

CADENAS ESPECIALES CON ALETAS "Z"

Aletas especiales de hueco oblongo montadas sobre una cadena conforme con la norma ISO 606

APLICACIONES

Transportadores, montaje en transportadores usando generalmente 2 cadenas en paralelo

EMPAREJAMIENTO POSIBLE PARA MÁS PRECISIÓN.

ENVÍO POSIBLE DENTRO 48 HORAS

Para las referencias indicadas

50M MÁXIMO (consúltenos)

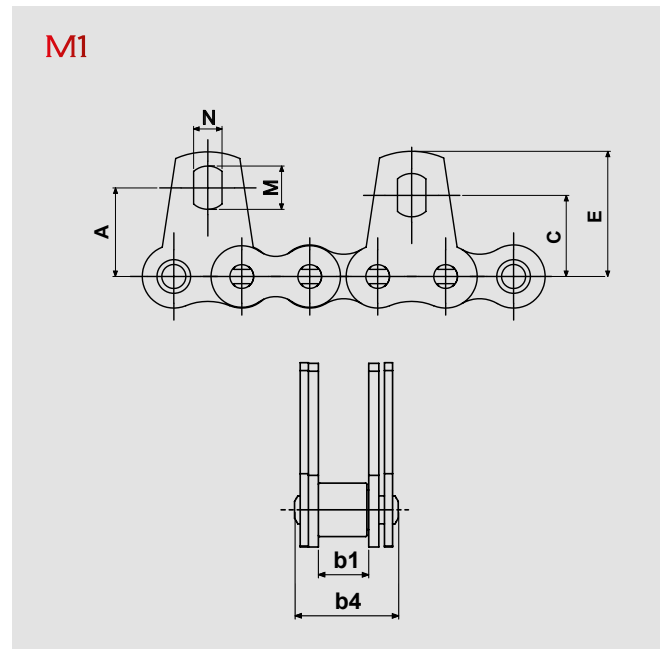
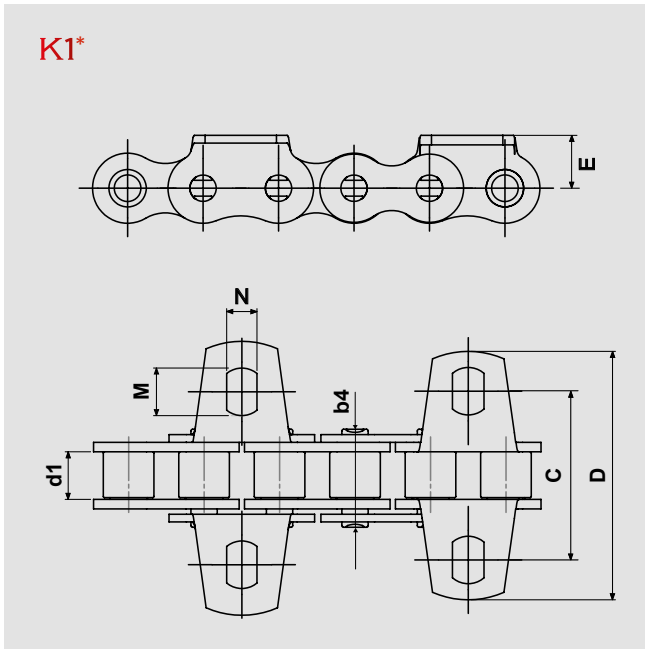

Dimensiones en mm

Referencia	Paso	GAMA SEDIS					d1	b1	b4	A	C	D	E	M	N	
		ALPHA Premium	ALPHA Premium INOX	DELTA® HR	DELTA TITANIUM 2	Cadenas VERTE										
ISO 606	SEDIS	mm					max.	min.	max.	nom.	nom.	max.	nom.	min.	min.	
Aletas K1 - Eslabón EXTERIOR																
08B-1	7N	12,7	x	x	x	x	(1)	8,51	7,75	16,6		28,5	45,3	9,2	8	5,2
Aletas K1 - Eslabón INTERIOR																
08B-1	7N	12,7	x	x	x	x		8,51	7,75	16,6		28,5	42	9,2	8	5,2
Aletas M1 - Eslabón EXTERIOR																
08B-1	7N	12,7	x	x	x	x	(1)	8,51	7,75	16,6	16,6	15,2	45,3	23,4	8	5,2
Aletas M1 - Eslabón INTERIOR																
08B-1	7N	12,7	x	x	x	x		8,51	7,75	16,6	16,6	15,2	42	23,4	8	5,2

(1): Referencias en versión Lub Free. En versión Delta®VERTE, consúltenos

Para enterarse de las resistencias a la tracción de las cadenas hay que referirse a las tablas de las páginas 18 y 20

* Montaje de las aletas K1 mínimo todo los 2 pasos