

# HOLLOW BEARING PIN CHAINS

## APPLICATIONS

In light handling, small conveyors usually using two parallel chains  
 Examples: transport of sprays, of toothpaste, packaging machinery

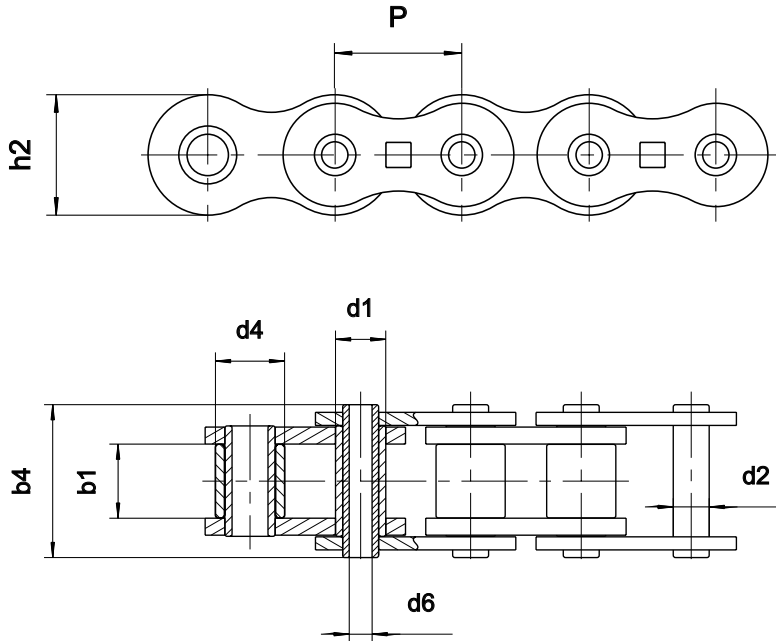

Dimensions in mm

References		Pitch  P	SEDIS RANGES				d1 max.	d4 max.	b1 min.	b4 max.	d2 max.	d6 min.	h2 max.	Nominal bearing surface mm <sup>2</sup>	Ultimate Tensile Strength				Mass per meter kg
ISO 606	SEDIS		ALPHA Premium	ALPHA Premium INOX	DELTA <sup>®</sup> HR	DELTA TITANIUM 2									ALPHA Premium	ALPHA Premium INOX	DELTA <sup>®</sup> HR	DELTA TITANIUM 2	
			x	x	x	x									min. kN	min. kN	min. kN	min. kN	
08B-1	7C40	12,7	x			8,51	.	7,75	16,50	6,55	4,00	11,80	73	11,1				0,58	
08B-1	7C45	12,7	x			8,51	.	7,75	16,50	6,55	4,50	11,80	73	11,1				0,53	
12B-1	13C	19,05	x			12,07	.	11,68	23,00	8,25	6,10	18,30	128	24,0				1,07	
16A-1	80C	25,4	x			15,88	.	15,87	32,60	11,58	8,05	24,00	260	41,2				2,00	
SEDIS Special chains	5508-03	25,4	x	(1)		.	17,10	19,90	35,70	11,11	8,20	20,80	292	44,0	15,0			2,40	
	5508-06	25,4	x			14,11	.	19,90	35,70	11,11	8,20	20,80	292	44,0				2,30	
	A55BC	41,75	x	(1)		.	17,10	19,90	35,70	11,11	8,20	21,65	292	26,5	17,6			1,43	
	A155TS	41,75	x		x	.	17,10	19,90	35,70	11,11	8,20	25,26	292	49,0		49,0	49,0	1,90	
	ZC50B50	50,8	x			22,51	.	19,00	46,60	17,10	12,50	32,00	540	90,0				3,70	
	ZC50S50	50,8	x			.	29,34	19,00	46,60	17,10	12,50	32,00	540	90,0				4,50	
	ZC60B60	60	x			22,51	.	19,00	46,60	17,10	12,50	32,00	540	90,0				3,40	
	ZC60S60	60	x			.	29,34	19,00	46,60	17,10	12,50	32,00	540	90,0				4,00	
S800	80	x			.	29,00	31,00	53,10	17,10	12,50	40,00	660	70,0				5,30		

(1): Possibility to manufacture Stainless steel version. Consult us for dimensions.

Other conveyor chains with hollow bearing pin: MC27, MC55, MC110 (See Conveyor Chains Catalogue)