

APPLICATIONS

These chains are usually used for feeding plastic sheets on thermoforming machines and bubble packing machines.

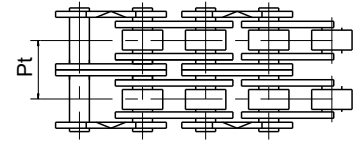

MATCHING POSSIBLE FOR HIGHER ACCURACY

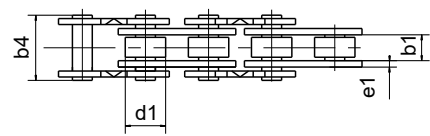
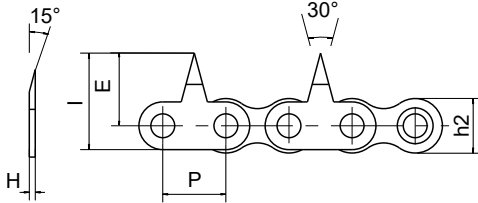

Dimensions in mm

References		Pitch P	SEDIS RANGE				d1 max.	b1 min.	b4	Pt	e1	E	h2	H	l
ISO 606	SEDIS		ALPHA Premium	DELTA® HR	DELTA TITANIUM 2	VERTE CHAINS									
BS standard chains (European series)															
08B-1	7N	12,7	x	x	x	(1)	8,51	7,75	16,60	13,92	1,6	14,5	11,8	1,5	20,4
10B-1	11N	15,875	x	x	x	(1)	10,16	9,65	19,00	16,59	1,6	16,0	13,7	1,5	22,2
Narrow width BS standard chains - (European series)															
	6N	12,7	x	x	x		8,51	5,35	14,10		1,6	14,5	11,8	1,5	20,4
	10N	15,875	x	x	x		10,16	6,50	16,60		1,6	16,0	13,7	1,5	22,2
ANSI standard chains (American series)															
08A-1	40-1	12,7	x	x	x		7,93	7,85	16,30	14,38	1,6	14,5	11,5	1,5	20,4
10A-1	50-1	15,875	x	x	x		10,16	9,65	20,85	18,11	2,0	16,4	13,7	2,0	23,2

- The spike attachments are fitted on outer links at spaces to be specified on the order, on one or both sides
- The spike attachment can be with a sharp or rounded end.
- For chains like 7N, 11N and 40, fitting is possible on duplex and triplex chains.
- For dimension b4, add 1 or 2 transver- sal pitches Pt.
- To know chains UTS, see tables on pages 18 to 21.

(1): References in Lub Free. In DELTA® VERTE please consult us

EXAMPLES OF SPIKED CHAINS

12,7mm chain pitch according to our drawing: 5083-84

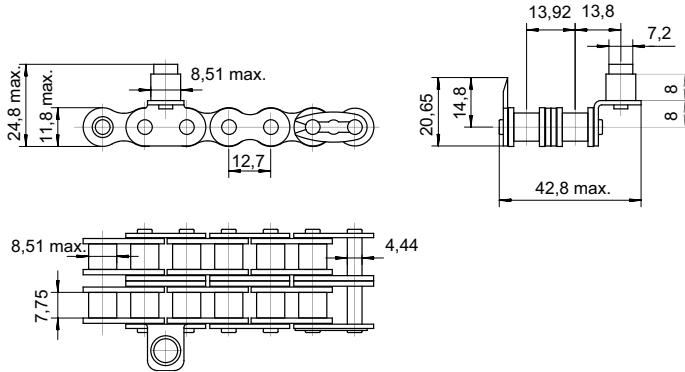

15,875mm chain pitch according to our drawing: 5273-40

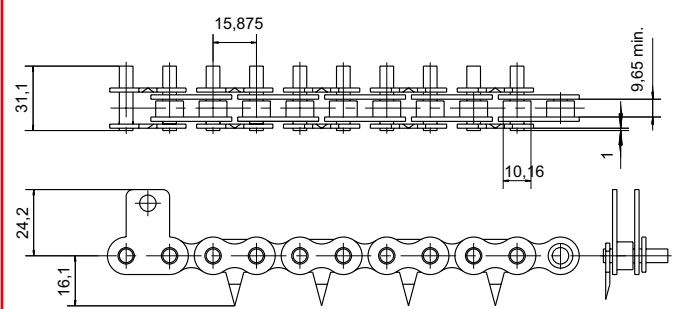

12,7mm chain pitch according to our drawing: 5083-82

