

**CHAINS WITH V-SHAPED PLATES** - Derived from ISO 606

**APPLICATIONS**

Conveying of cylindrical parts placed directly on the "V" plates.



**TYPE 1**

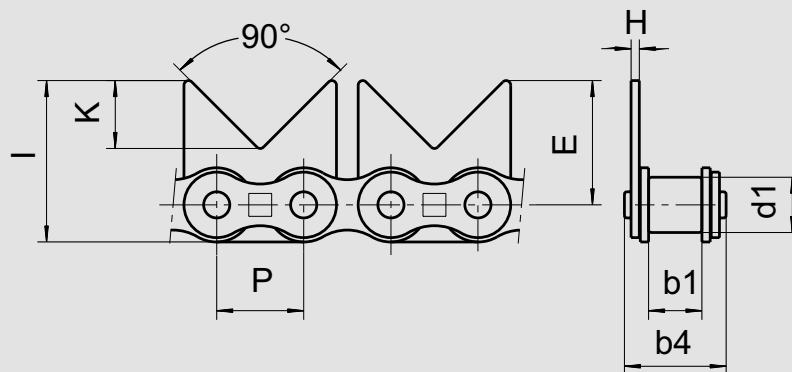

**TYPE 2**

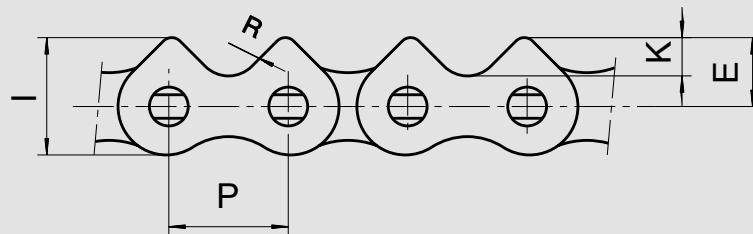

Dimensions in mm

References		Pitch P	VERSIONS			d1 max.	b1 min.	b4 max.	V type	E	H	I	K	R	Minimum Breaking load kN
ISO 606	SEDIS		ALPHA Premium	DELTA® HR	DELTA TITANIUM 2										
081	4L	12,7	x	x	x	7,70	3,30	8,65	1	16,25	1,2	21,25	11,0	.	8,0
	5T	12,7	x	.	.	7,76	5,00	12,30	1	16,25	1,0	20,35	11,0	.	11,6
12 B-1	13N	19,05	x	x	x	12,07	11,68	22,30	1	28,00	1,8	36,00	16,0	.	30,5
16 B-1	15T	25,4	x	x	x	15,88	17,02	35,10	2	14,50	3,0	24,80	6,5	7	66,0
20 B-1	17T	31,75	x	x	x	19,05	19,56	40,50	2	18,10	3,9	30,70	8,6	10	105,0
32B-1	22T	50,80	x	x	x	29,21	30,95	70,10	2	30,00	6,0	51,05	16,1	13	270,0